

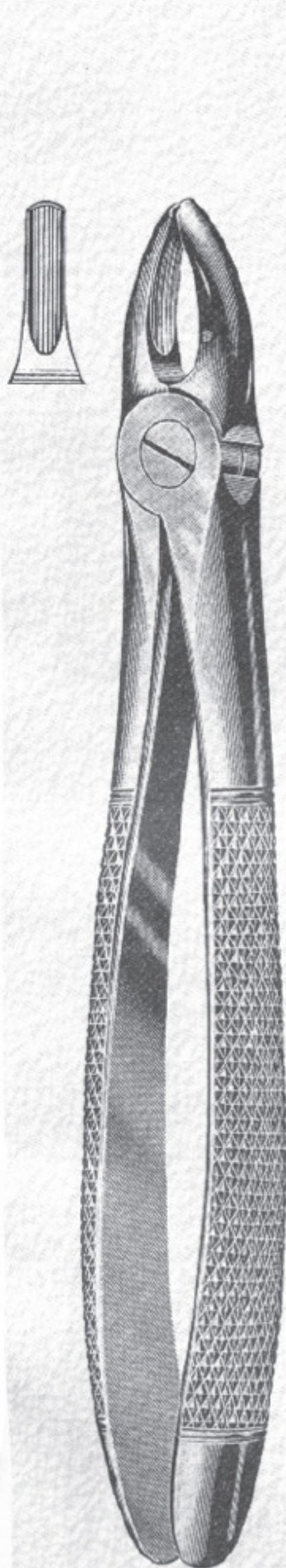

Extracting Forceps English Pattern



786-101
Fig.1
Upper centrals
& canines



786-102
Fig.2
Upper laterals
& bicuspids



786-103
Fig.3
Upper incisors
& canines

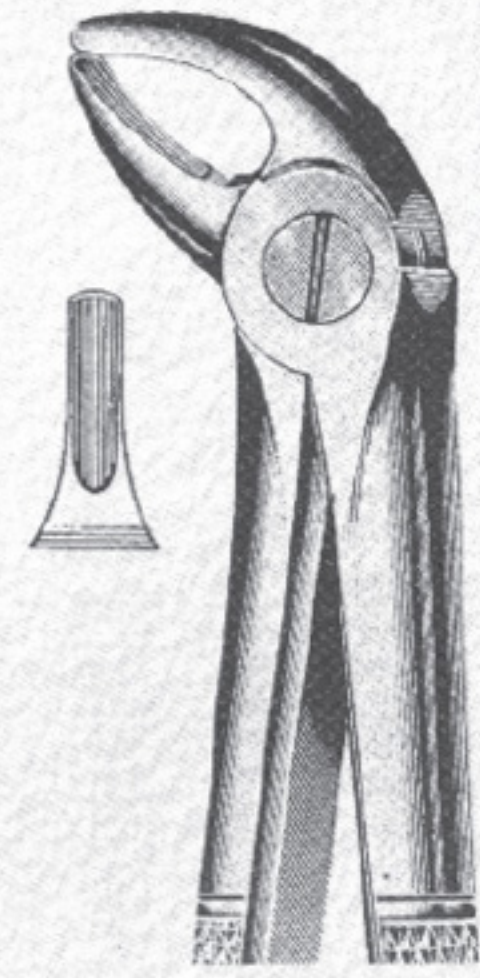

786-104
Fig.4
Lower incisors
& Canines

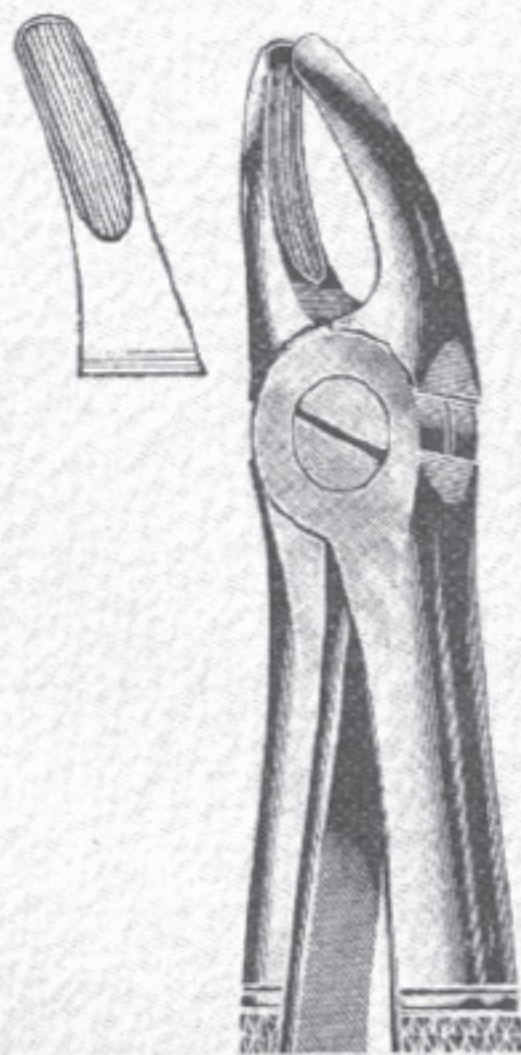

786-105
Fig.7
Upper primolars



786-106
Fig.8
Lower primolars

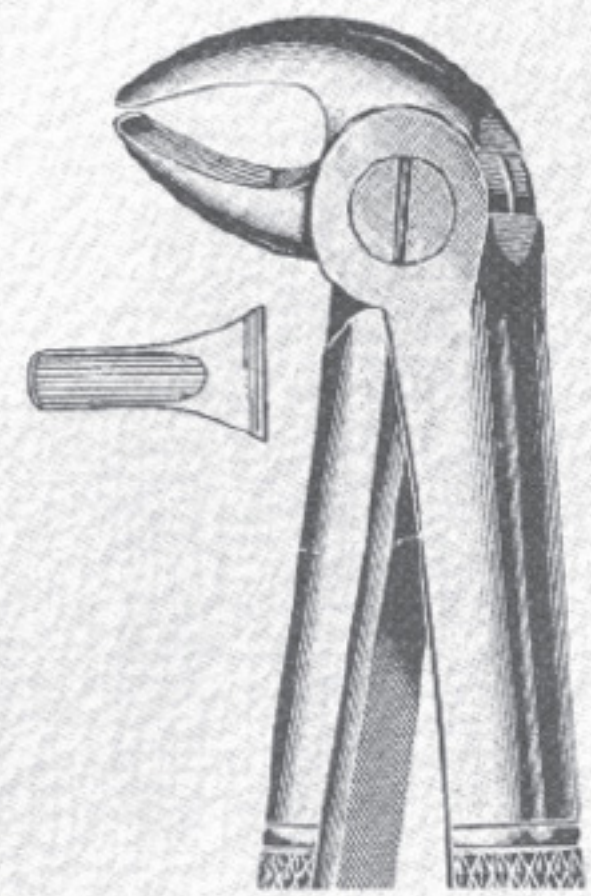

786-107
Fig.13
Lower primolars



Extracting Forceps English Pattern

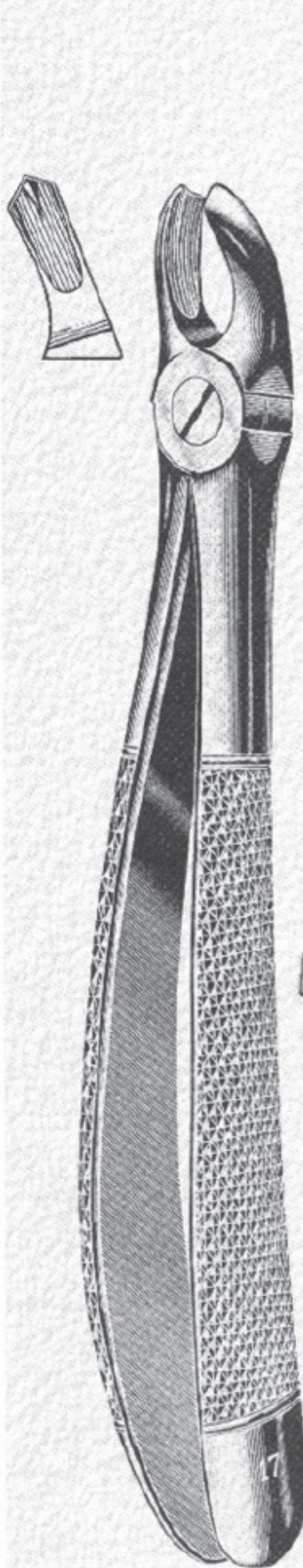

786-108
Fig. 17
Right upper molars

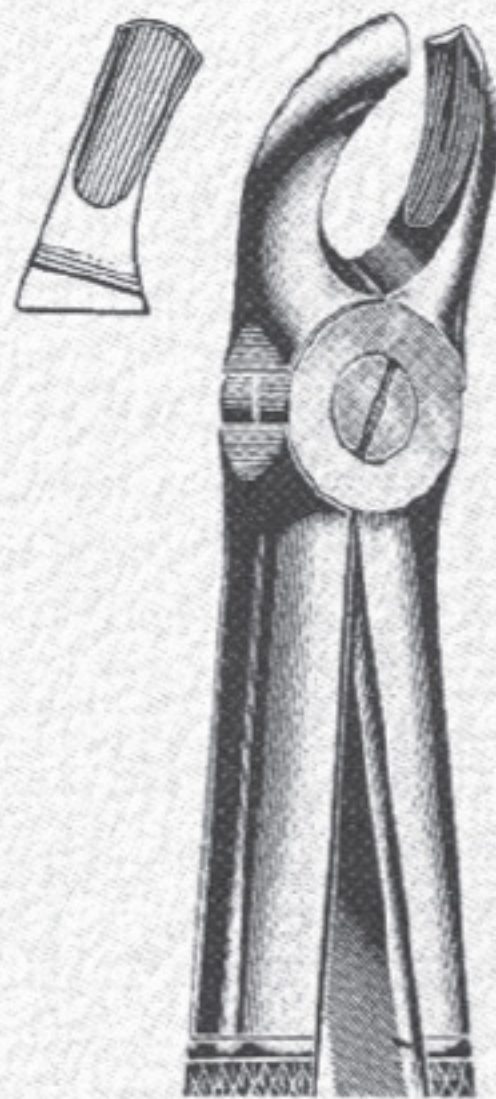

786-109
Fig. 18
Left upper molars



786-110
Fig. 18A
Upper molars



786-111
Fig. 19
Upper wisdoms

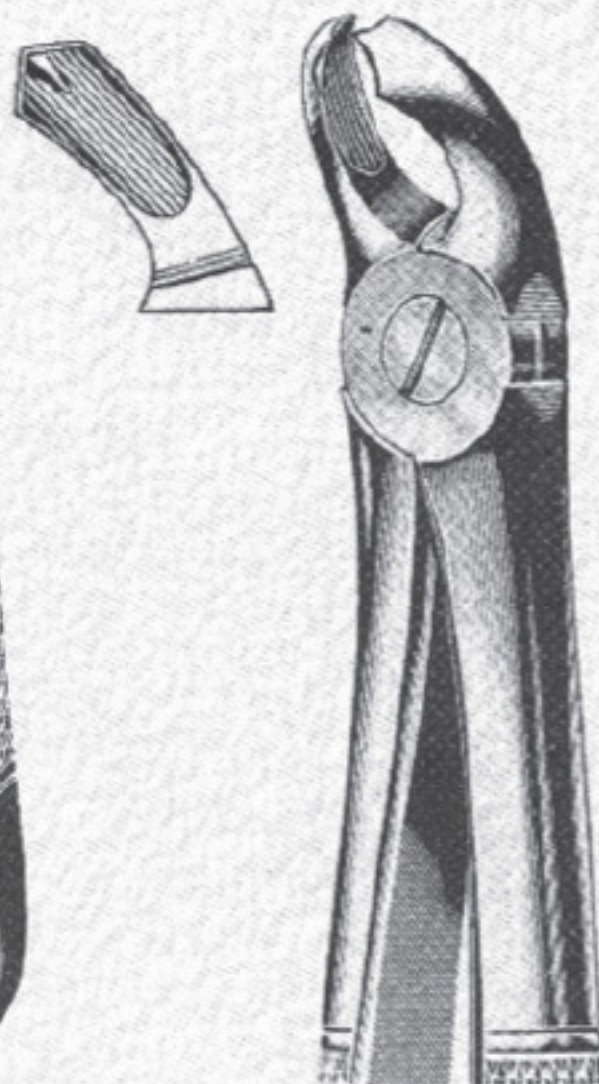

786-112
Fig. 20
Lower wisdoms



786-113
Fig. 21
Lower molars

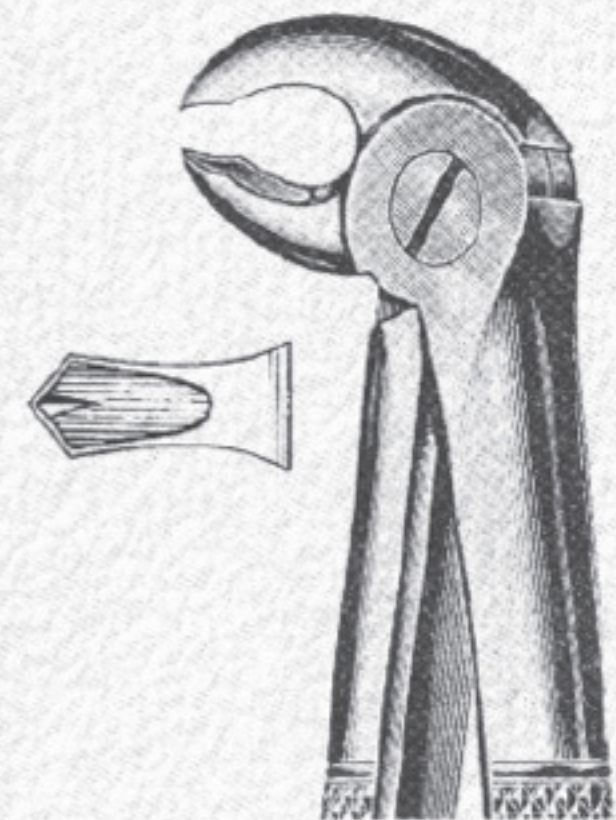

786-114
Fig. 22
Lower molars
Hawk's bill



EXTRACTING FORCEPS ENGLISH PATTERN



786-115
Fig.23
Right lower molars



786-116
Fig.24
Left lower molars

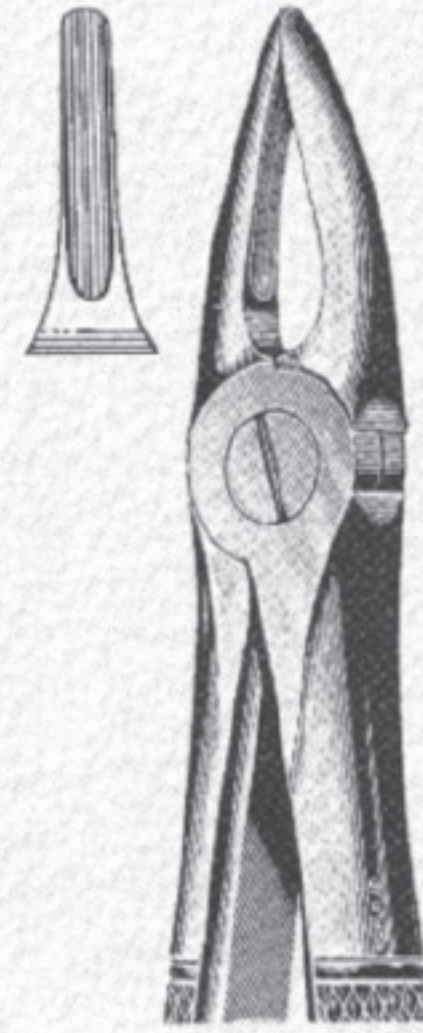

786-117
Fig.29
Upper roots
& incisors

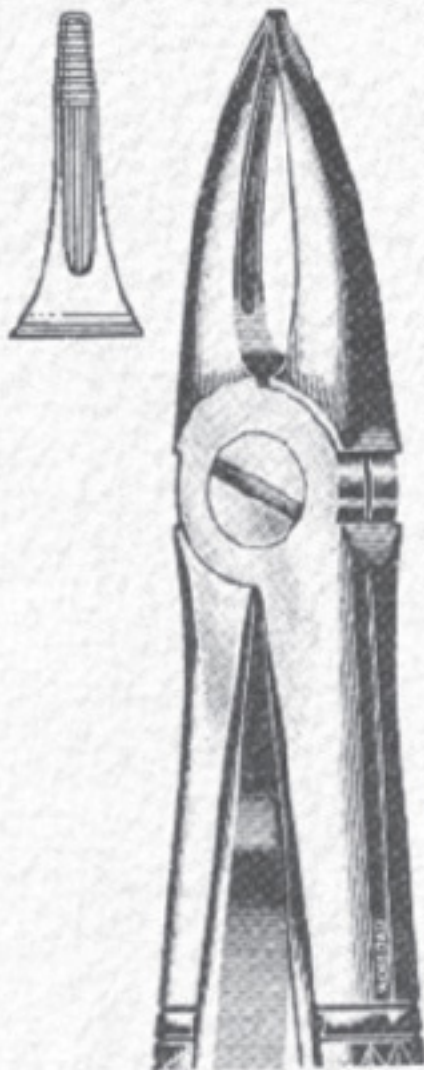

786-118
Fig.29N
Roots of upper
incisors



786-119
Fig.30
Upper roots &
incisors



786-120
Fig.31
Lower roots



786-121
Fig.32
Lower molars



Extracting Forceps English Pattern

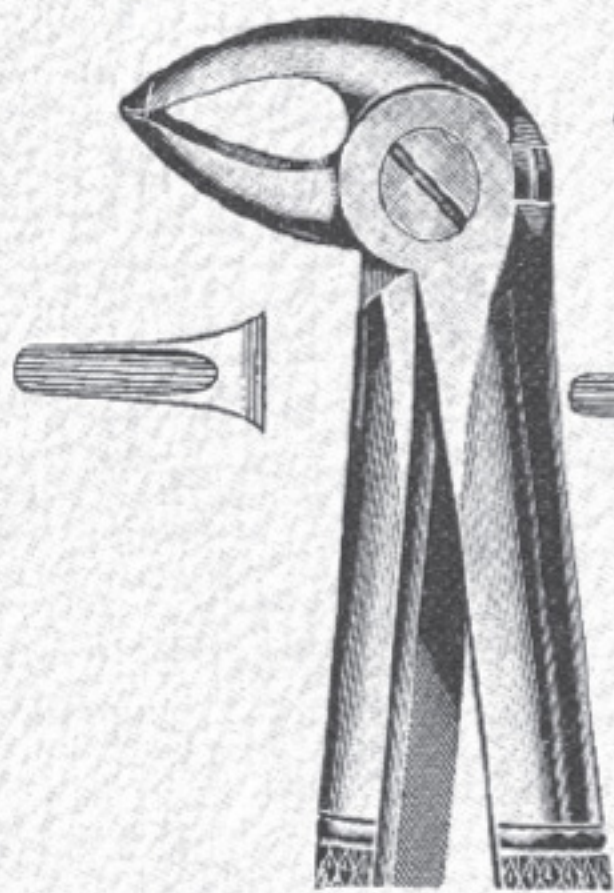

786-122
Fig.33
Lower roots

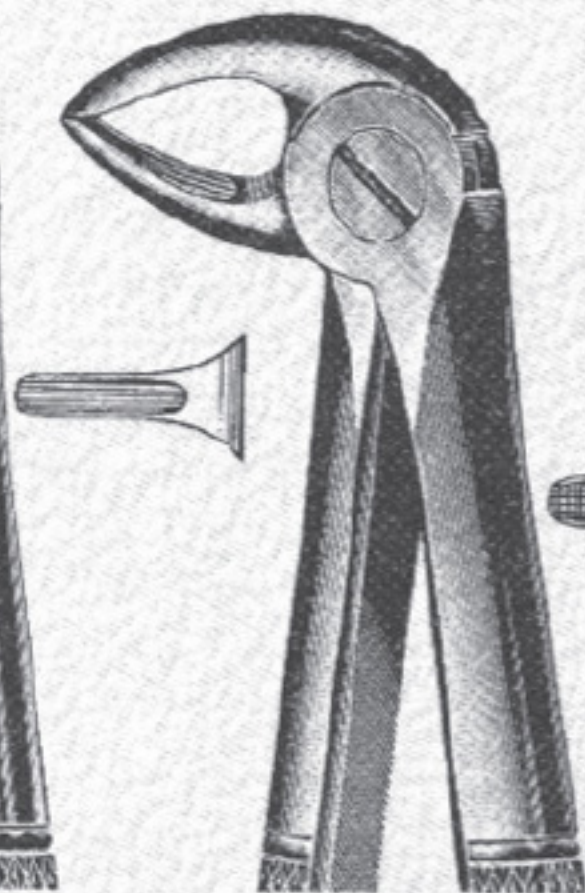

786-123
Fig.33A
Lower roots

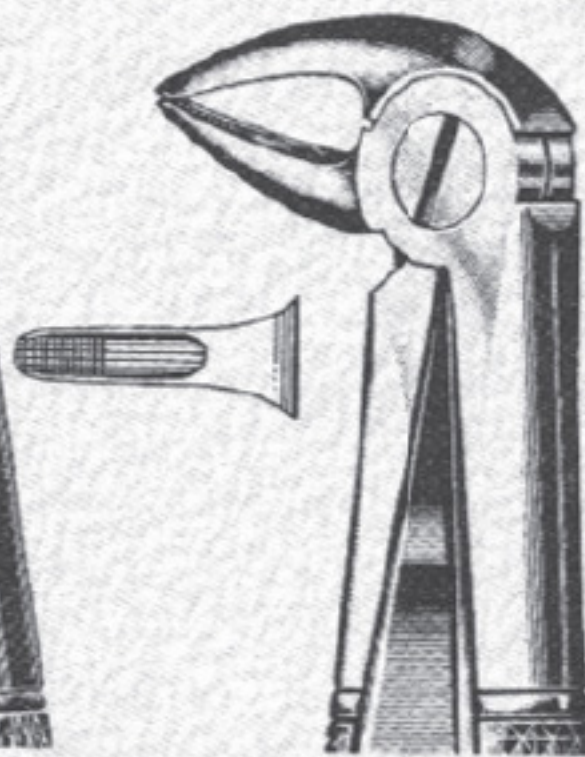

786-124
Fig.33C
Lower roots

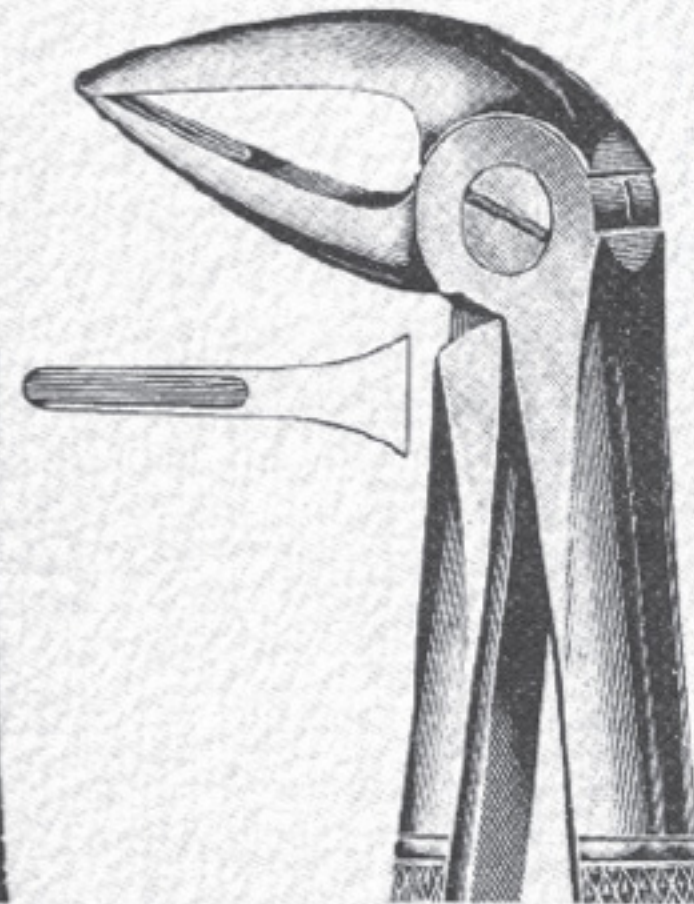

786-125
Fig.33M
Lower roots
with long beak

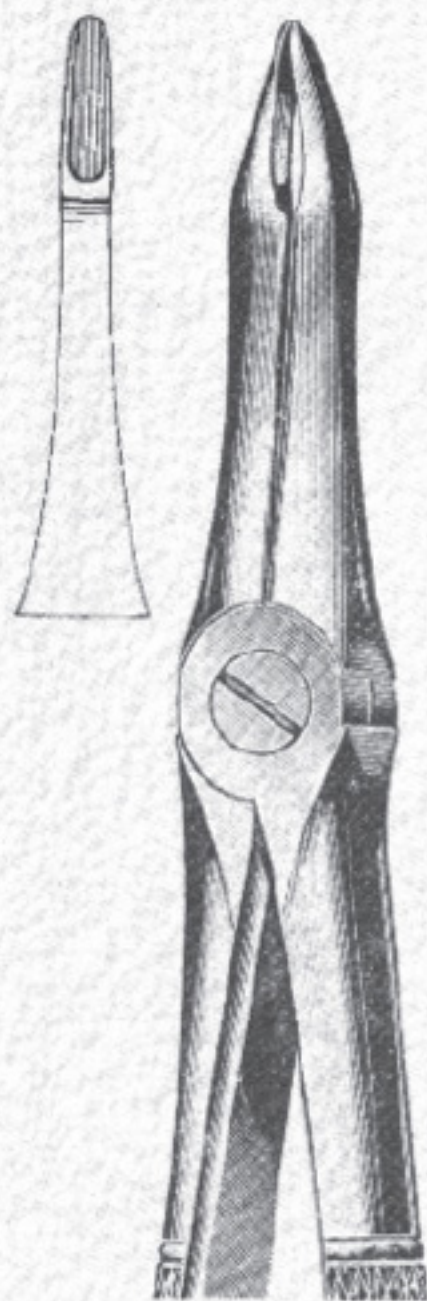

786-126
Fig.41
Upper roots

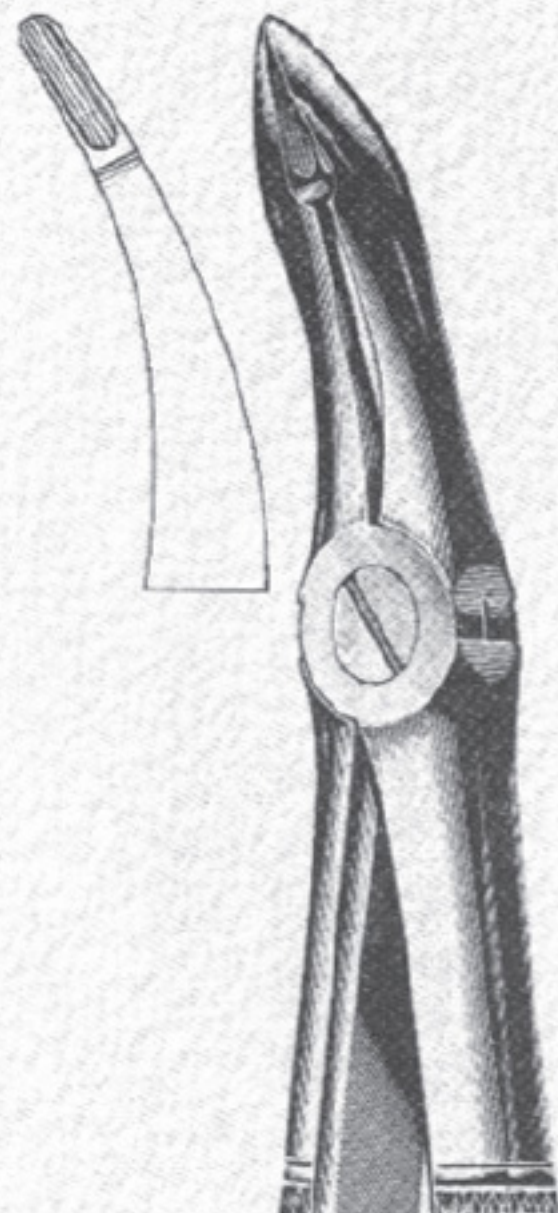

786-127
Fig.44
Upper roots

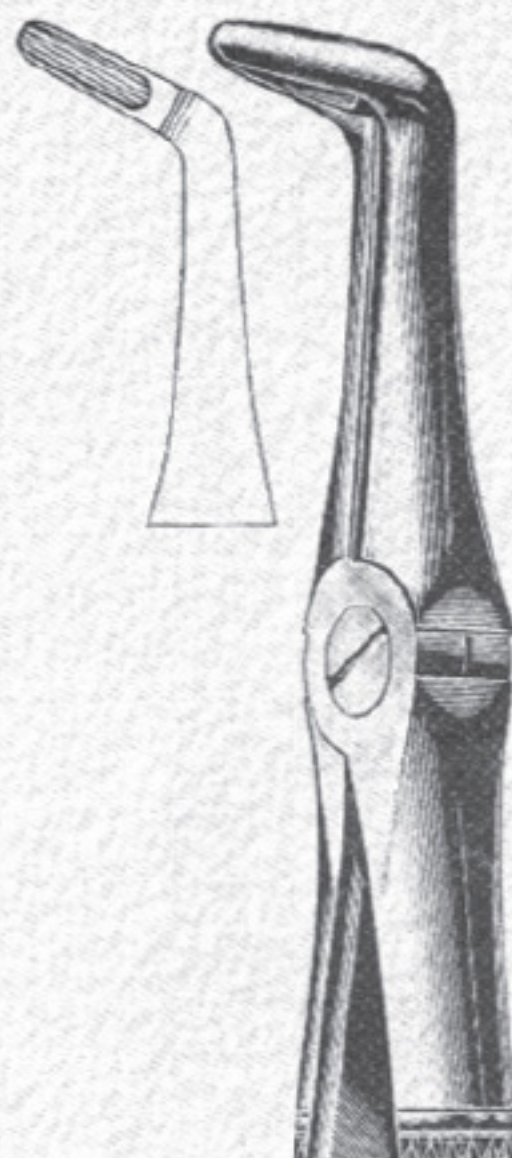

786-128
Fig.45
Lower roots

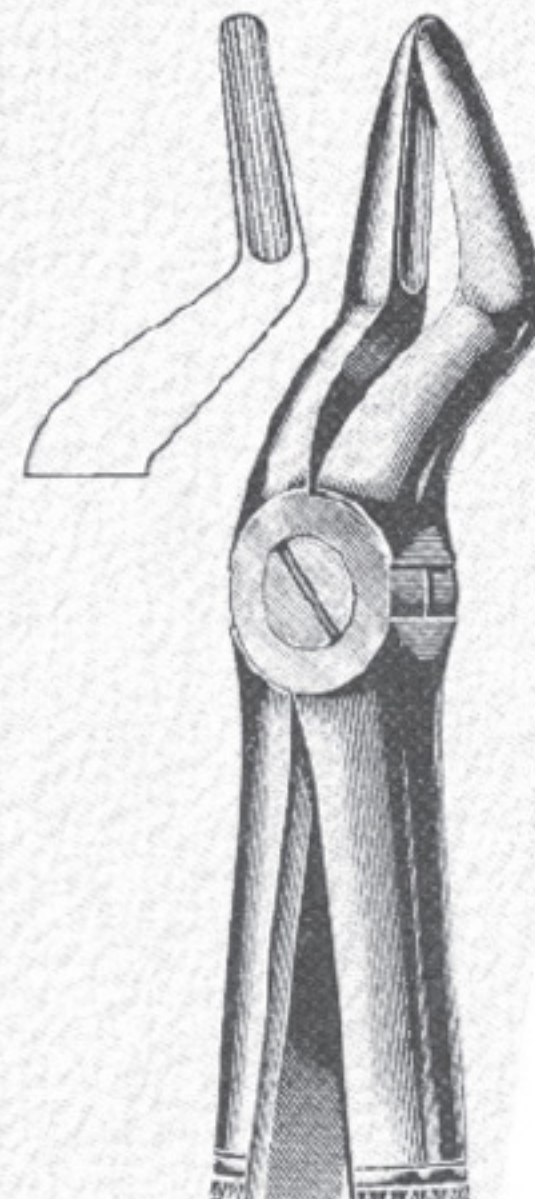

786-129
Fig.51
Upper roots



Extracting Forceps English Pattern

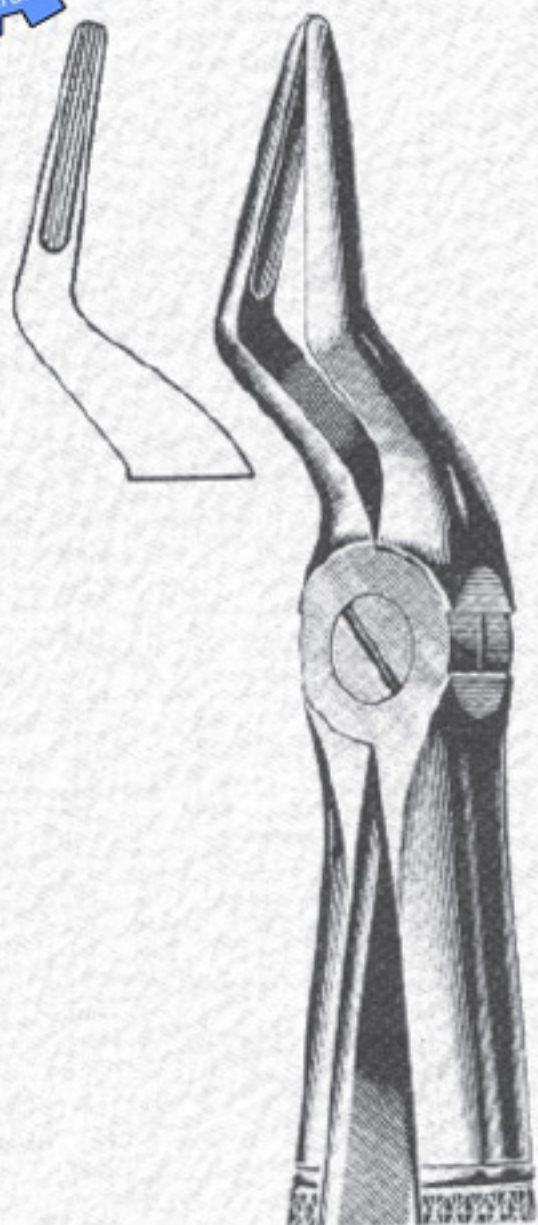

786-130
Fig.51A
Upper roots
narrow beak

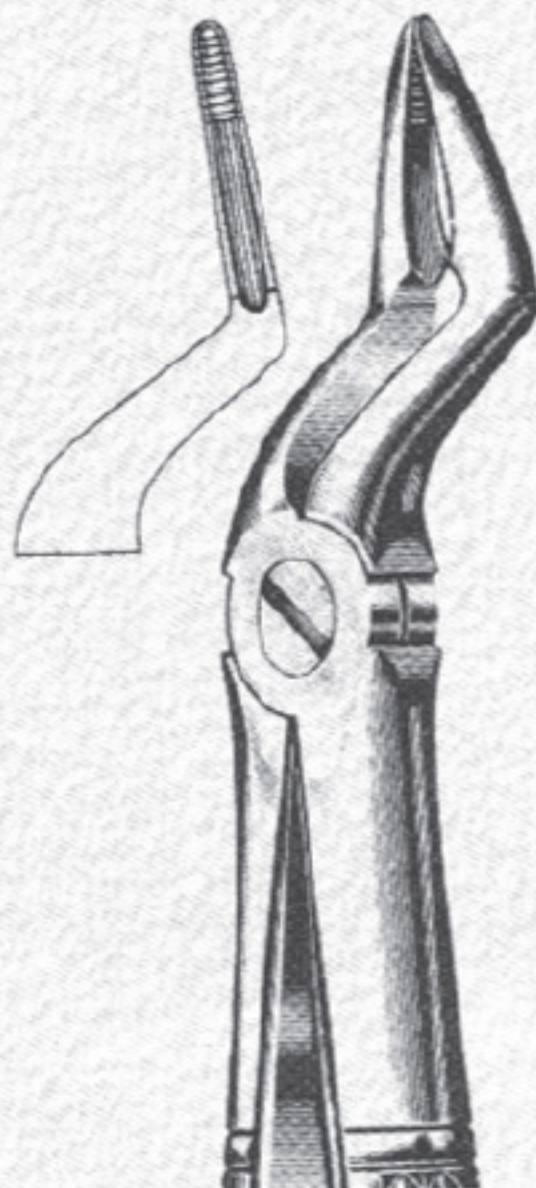

786-131
Fig.51C
Upper roots

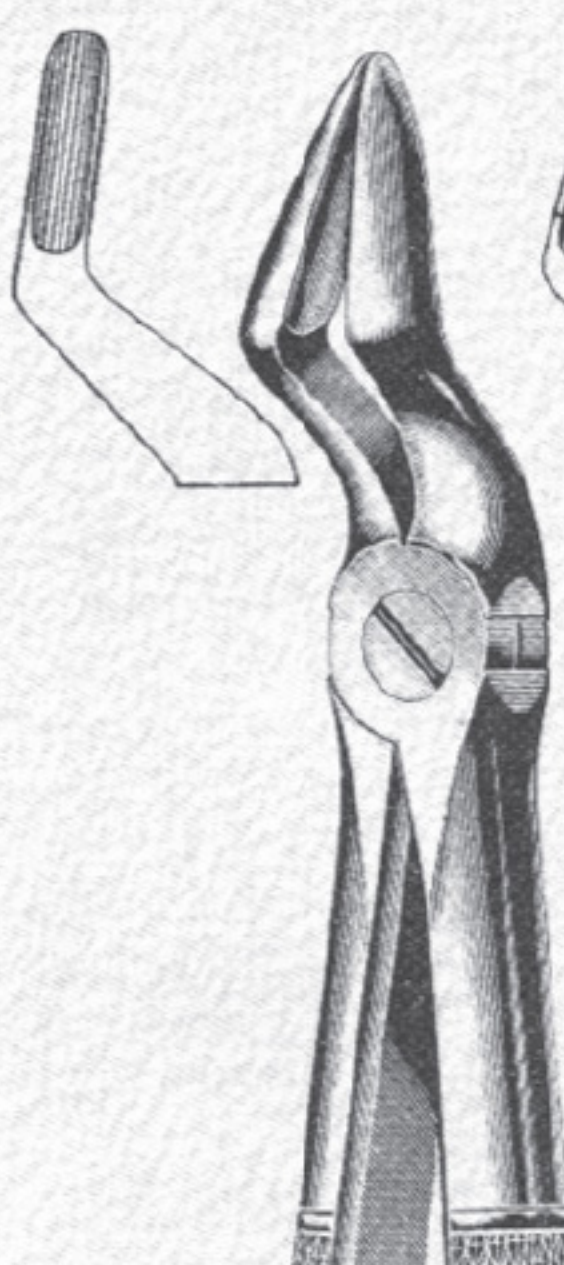

786-132
Fig.52
Upper roots & canines
with wider beak

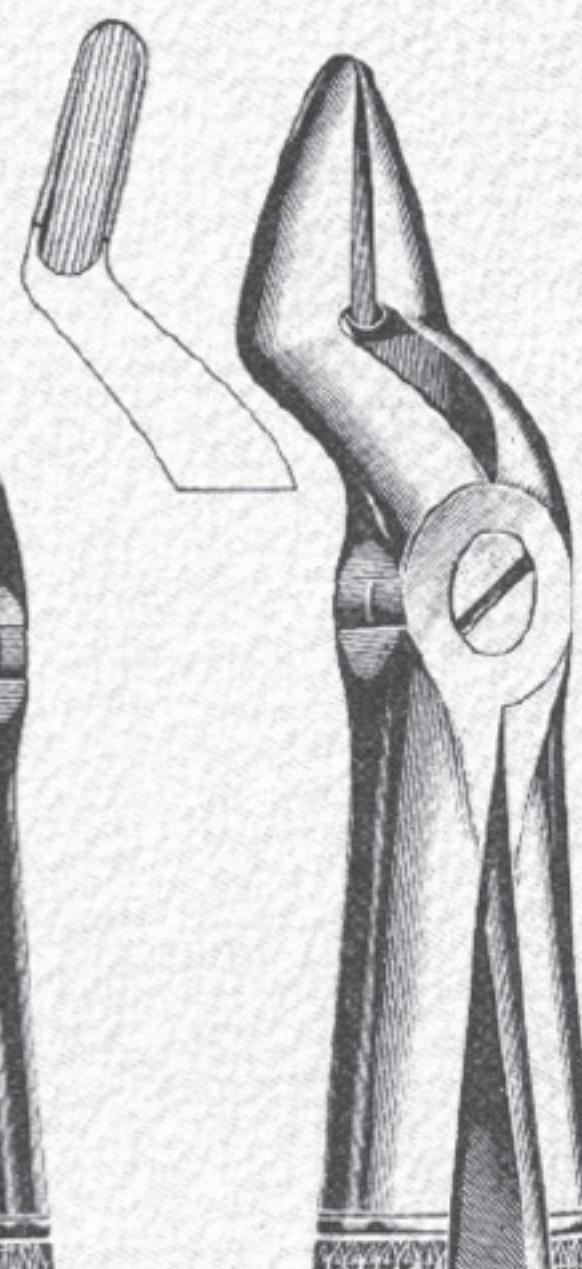

786-133
Fig.52A
Upper teeth &
resection

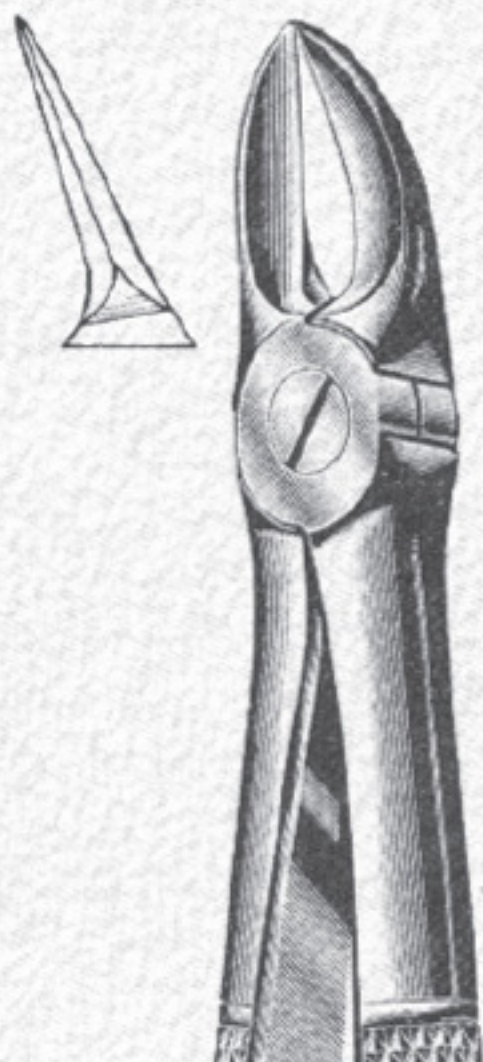

786-134
Fig.55
Separating upper
molars roots



786-135
Fig.56
Separating lower
molars roots

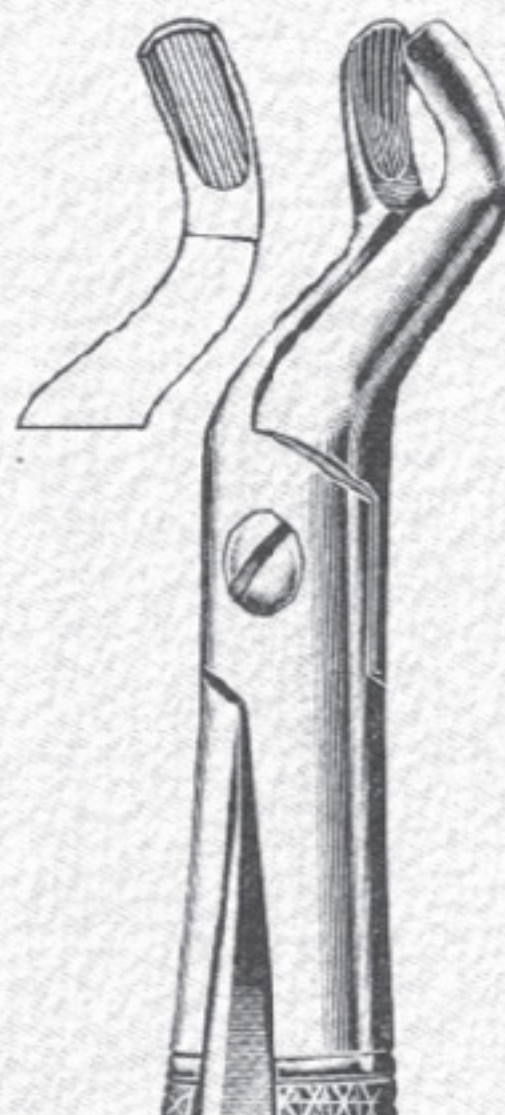

786-136
Fig.67
Upper wisdoms

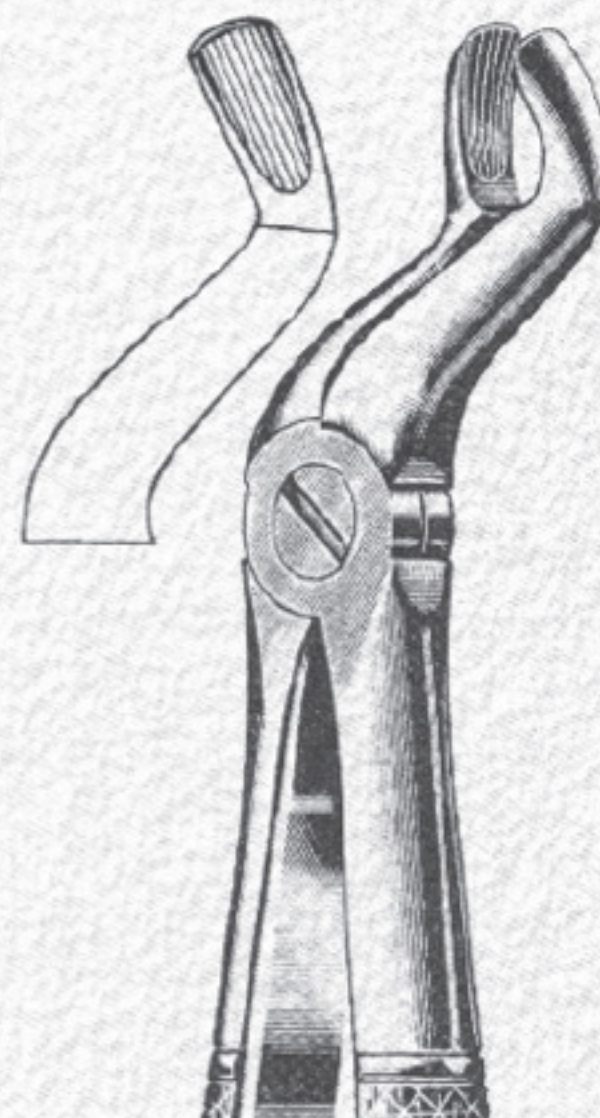

786-137
Fig.67A
Upper wisdoms



Extracting Forceps English Pattern

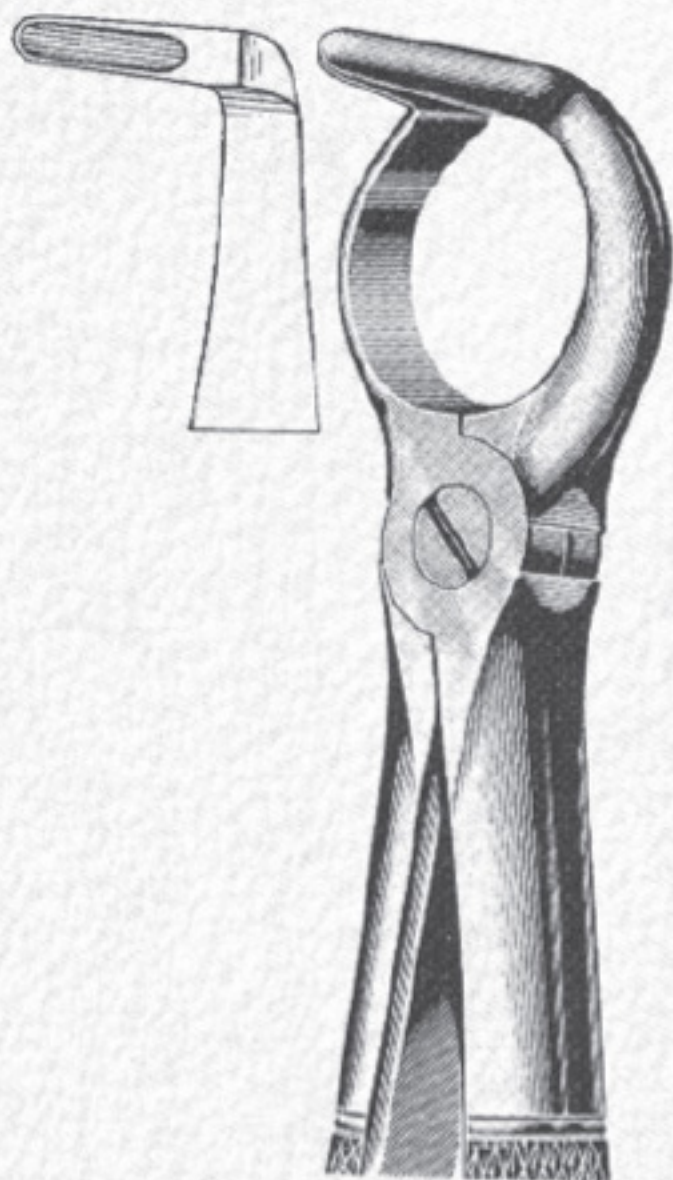

786-138
Fig. 68
Lower roots

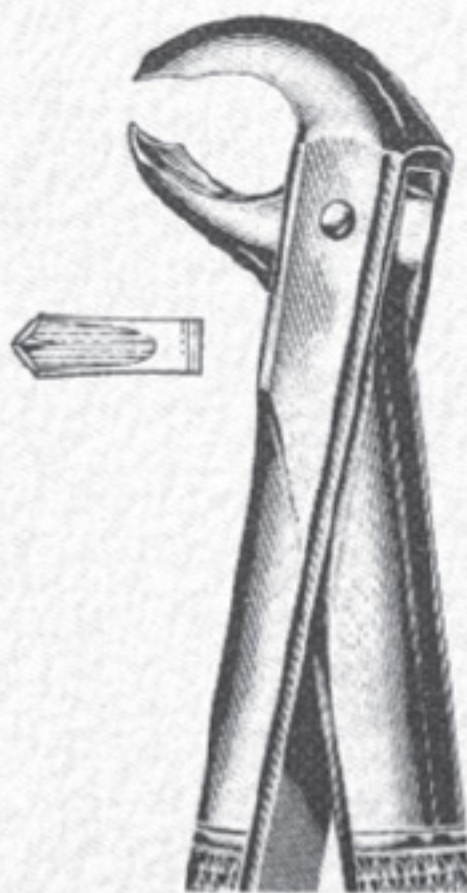

786-139
Fig. 73
Lower molars
(Hawk's bill)

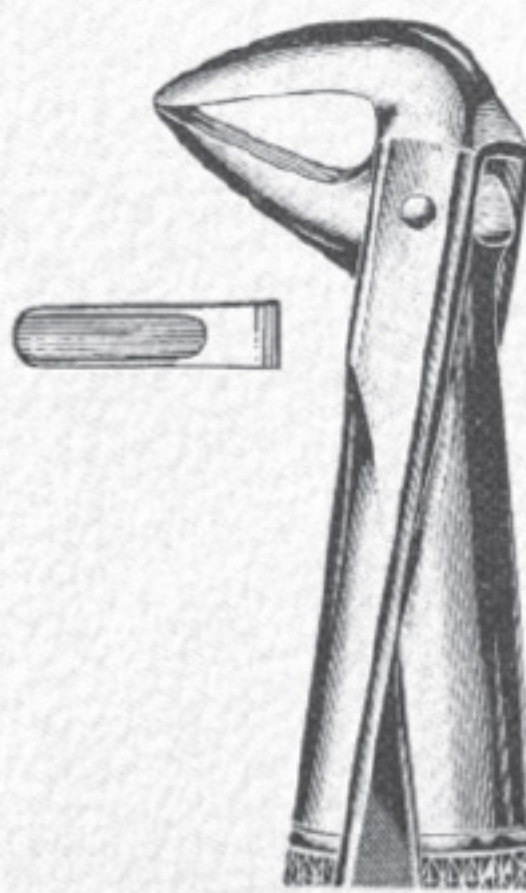

786-140
Fig. 74
Lower incisors
& roots

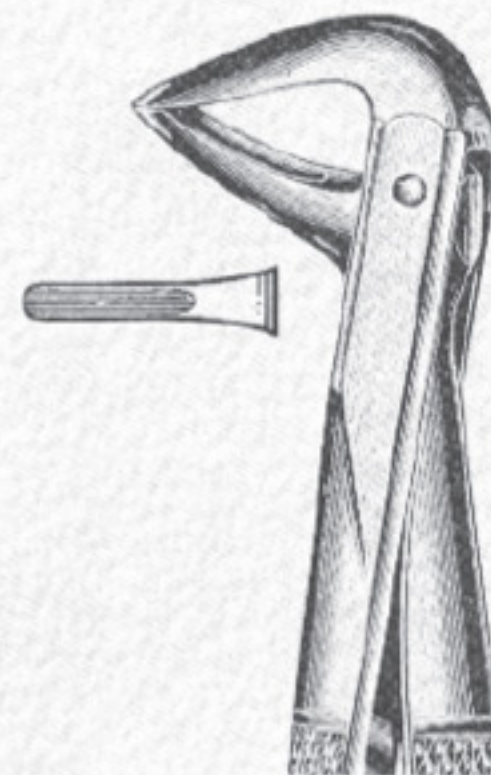

786-141
Fig. 74M
Lower incisors
& roots



786-142
Fig. 74N
Lower incisors
& roots

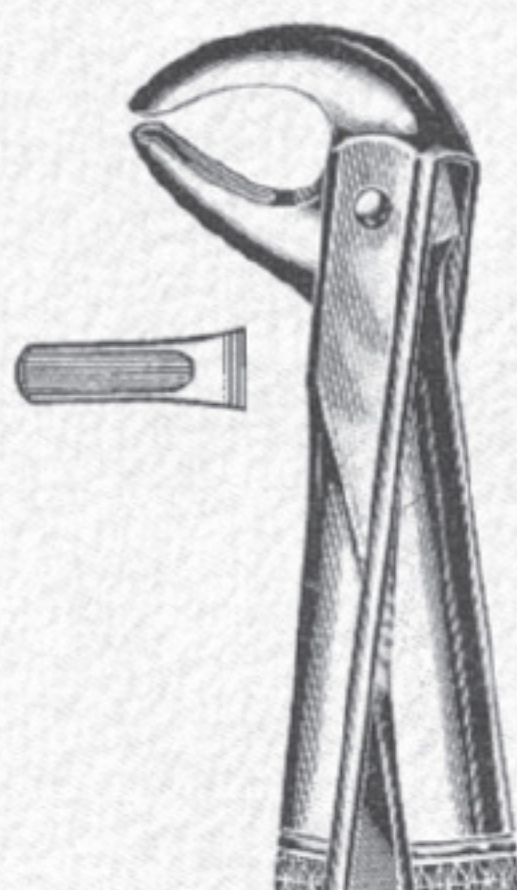

786-143
Fig. 75
Lower premolars
& canines



786-144
Fig. 76
Upper roots



786-145
Fig. 76N
Upper roots
(narrow beak)



Extracting Forceps English Pattern

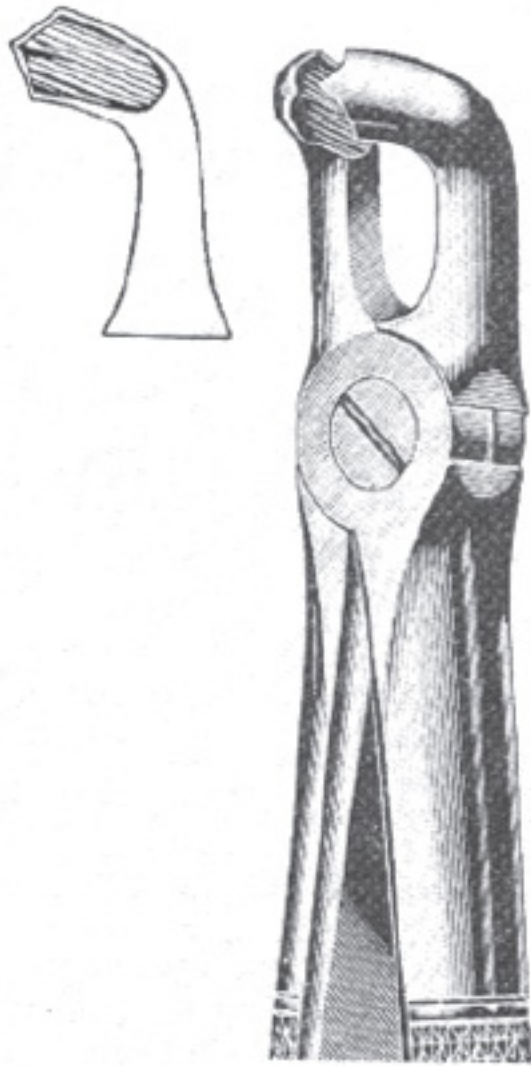

786-146
Fig. 79
Lower wisdoms

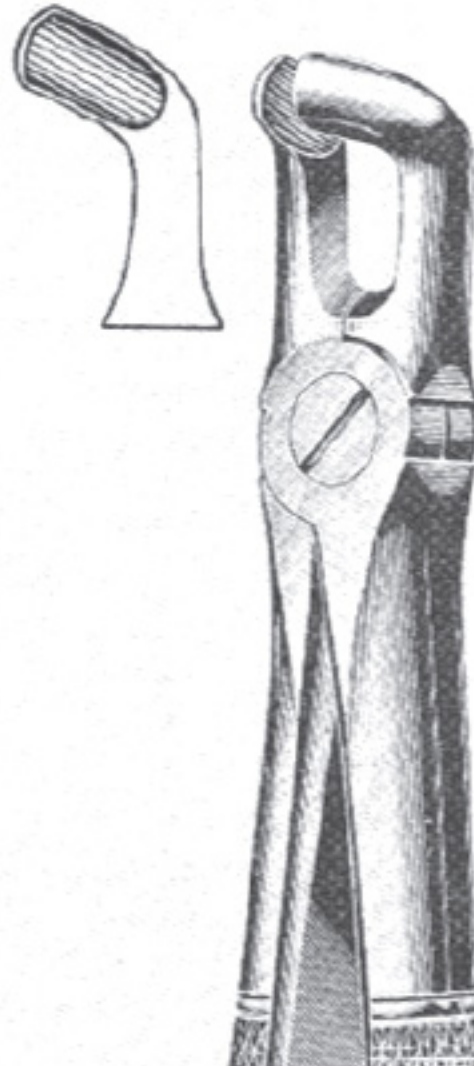

786-147
Fig. 79A
Lower wisdoms

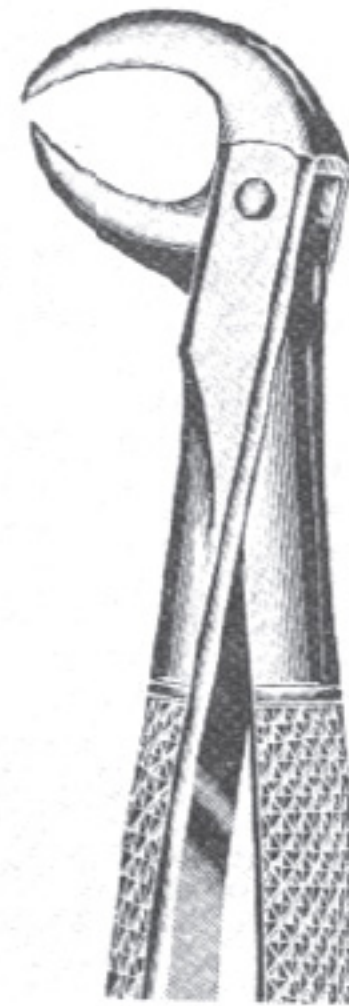

786-148
Fig. 86A
Lower molars

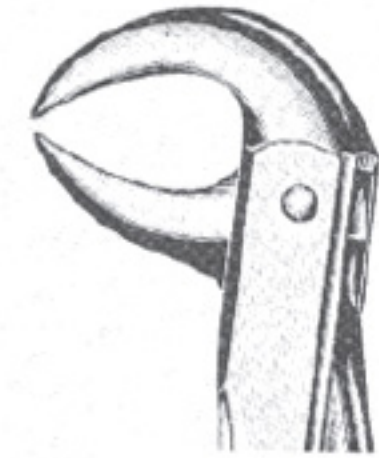

786-149
Fig. 86B
Lower molars



786-150
Fig. 86C
Lower molars

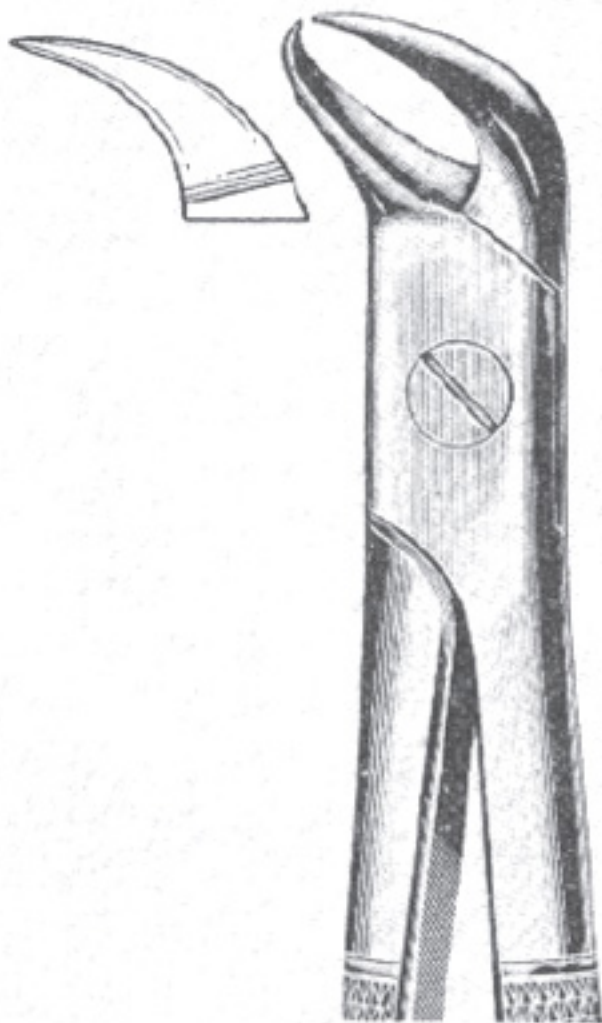

786-151
Fig. 87
Cowhorn beak

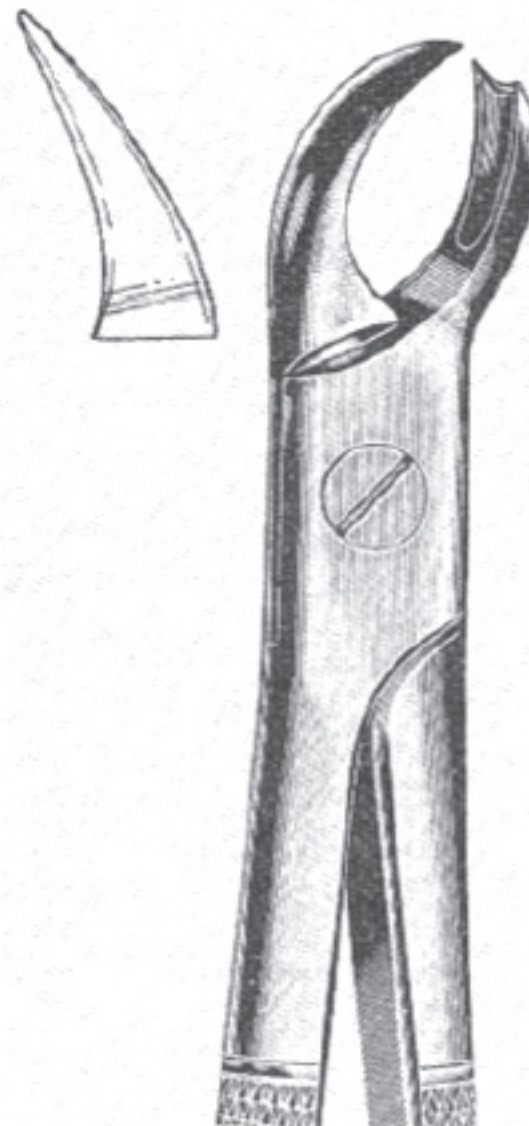

786-152
Fig. 89
Right upper molars

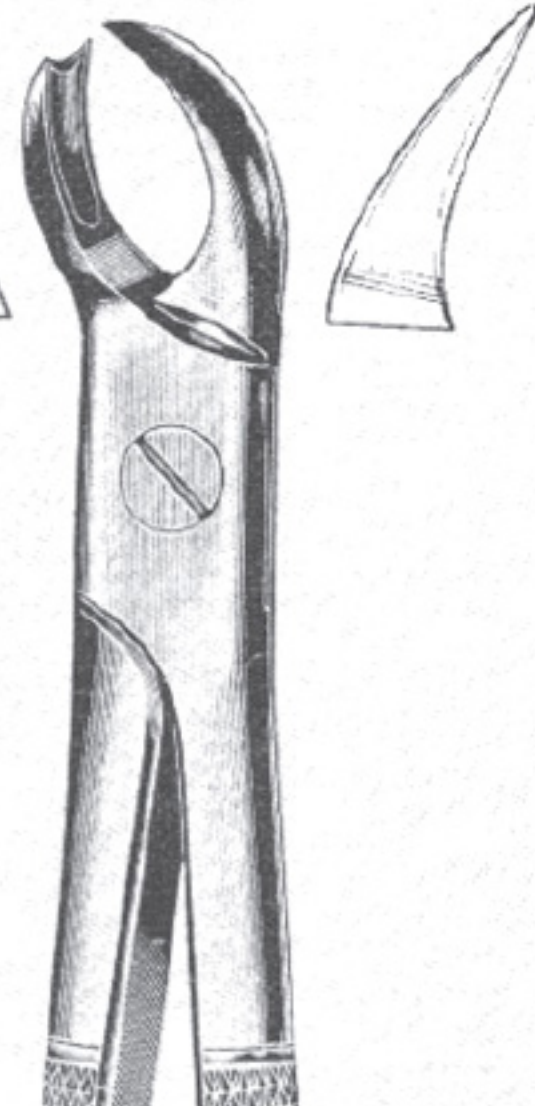
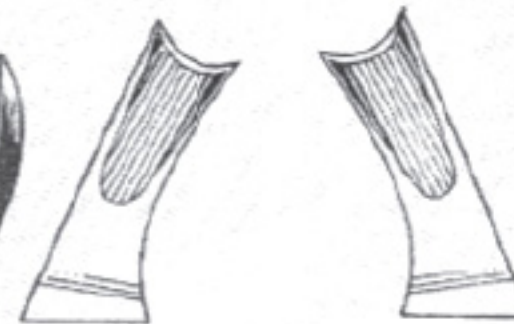

786-153
Fig. 90
Left upper molars



Extracting Forceps English Pattern

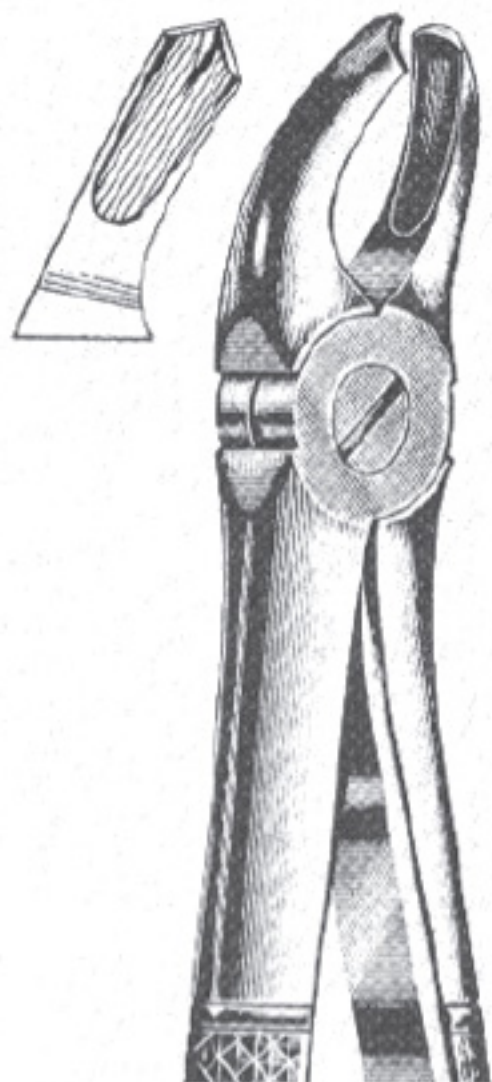

786-154
Fig.94
Right upper molars

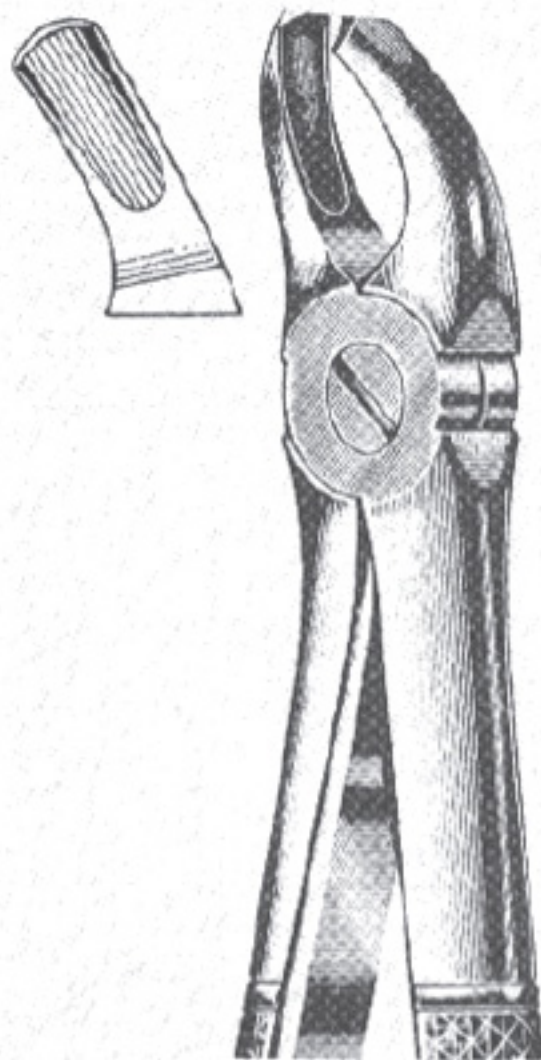

786-155
Fig.95
Left upper molars

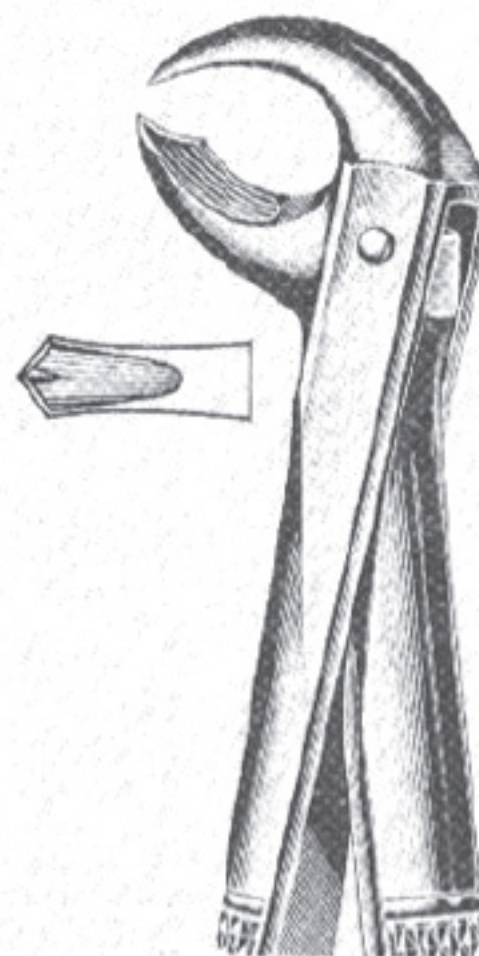

786-156
Fig.99
Lower molars
(broken-down)



786-157
Fig.99 1/4
Lower molars
(broken-down)

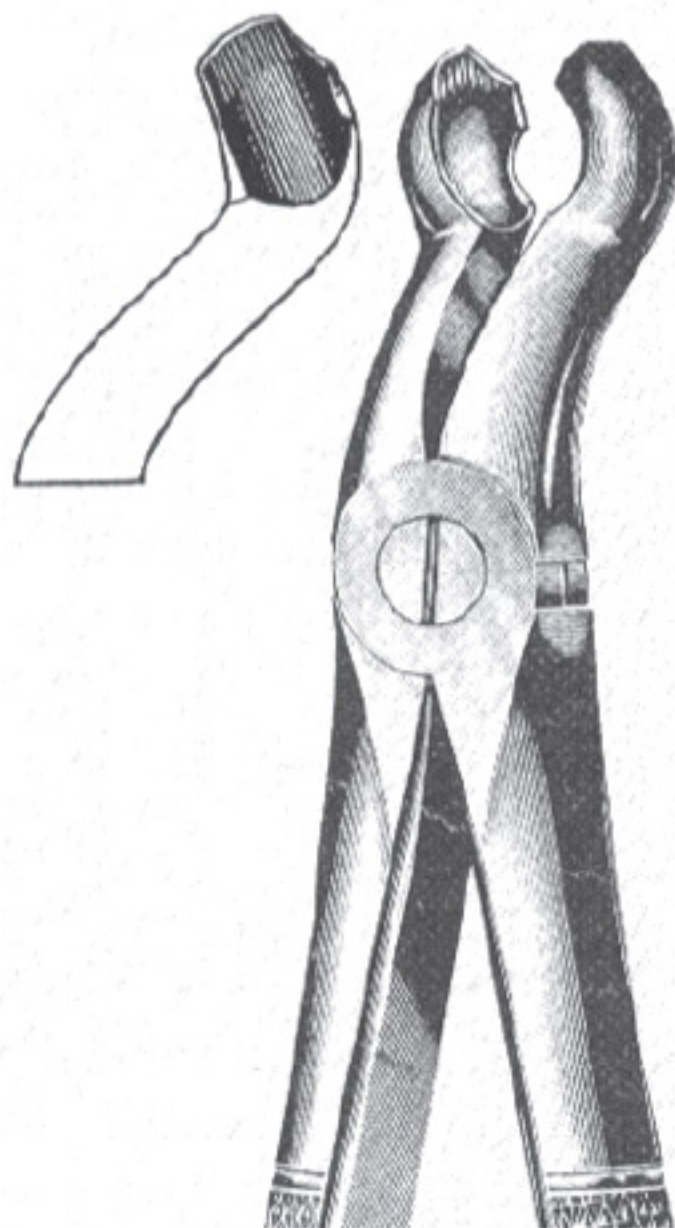

786-158
Fig.121
Upper wisdoms



786-159
Fig.136
Upper centrals
& roots



786-160
Fig.137
Lower centrals
& roots

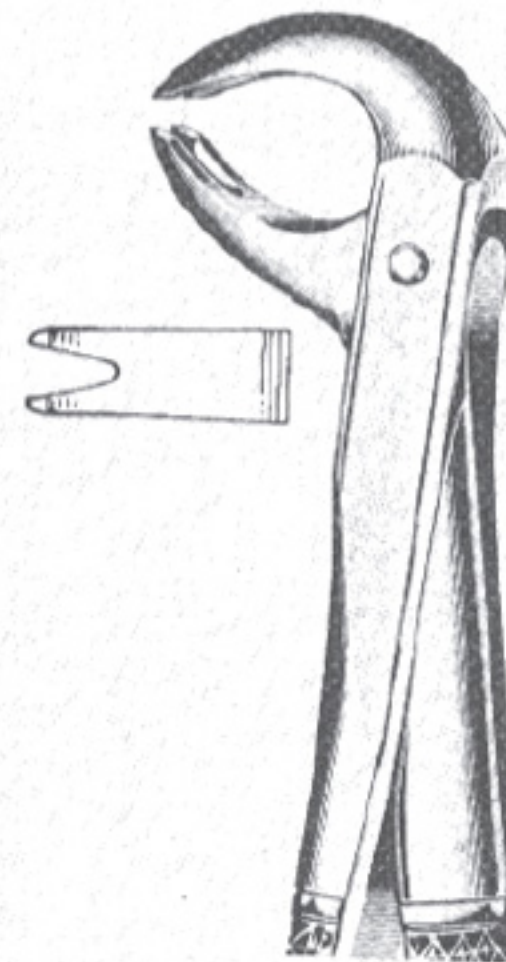

786-161
Fig.167
Universal patter
for lower teeth
molars & premolars



Extracting Forceps English Pattern

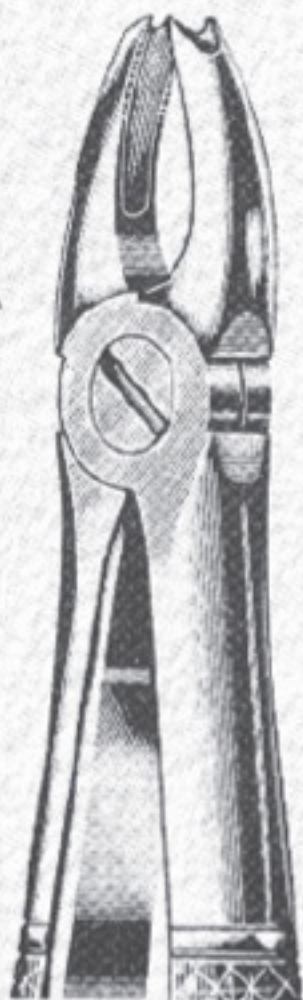
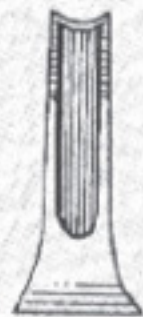

786-162
Fig. 168
Upper canines



786-163
Fig. 169
Lower canines
& premolars

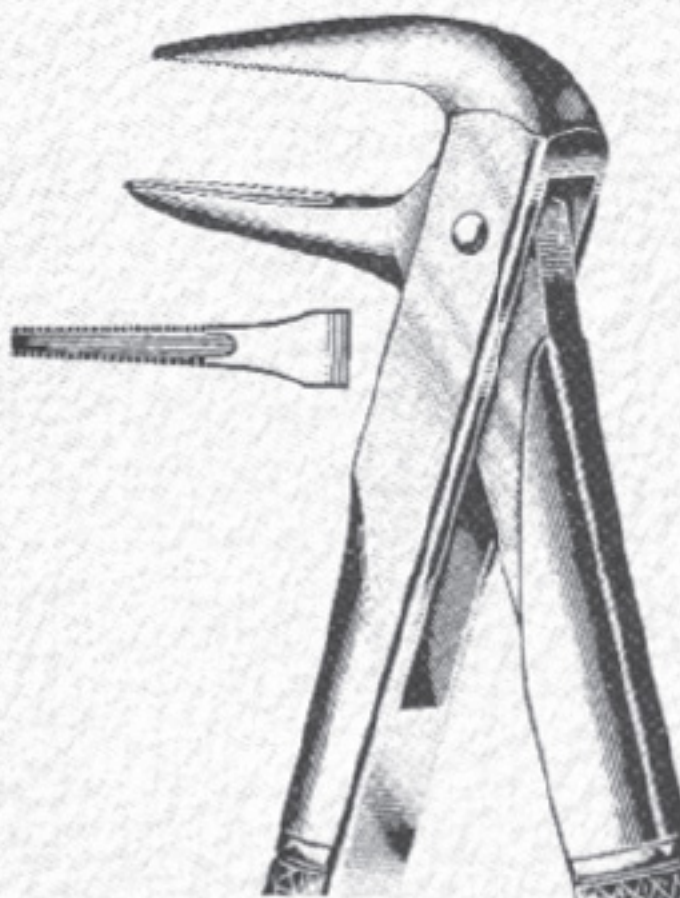

786-164
Fig. 233
Lower roots
(parallel beaks)

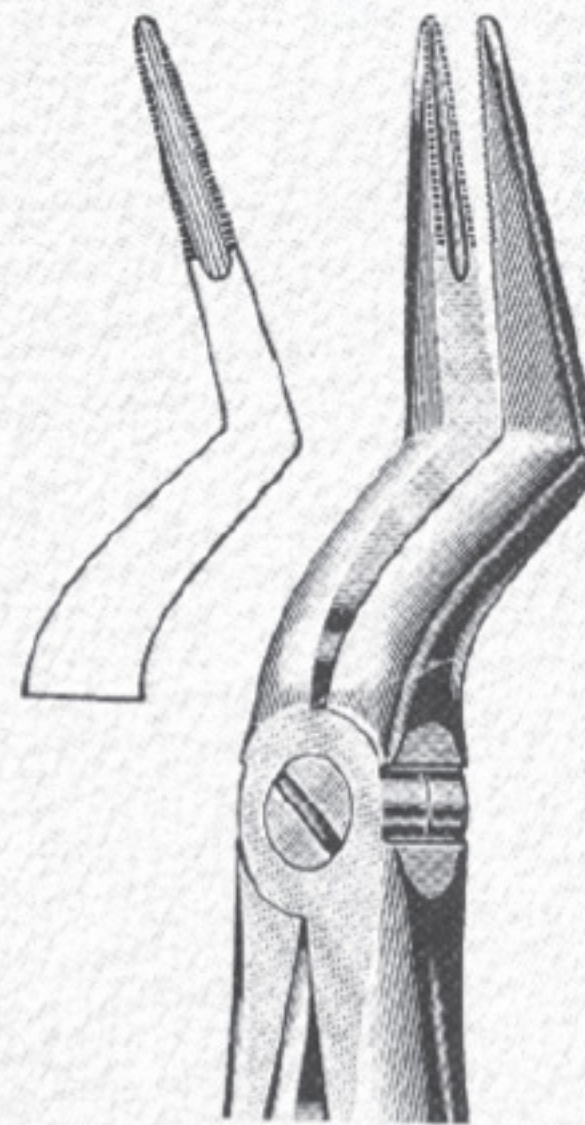

786-165
Fig. 235
Upper roots
(parallel beaks)



786-166
Fig. MD 1
Universal forceps for upper
wisdoms, premolars & roots



786-167
Fig. MD 2
Upper molars

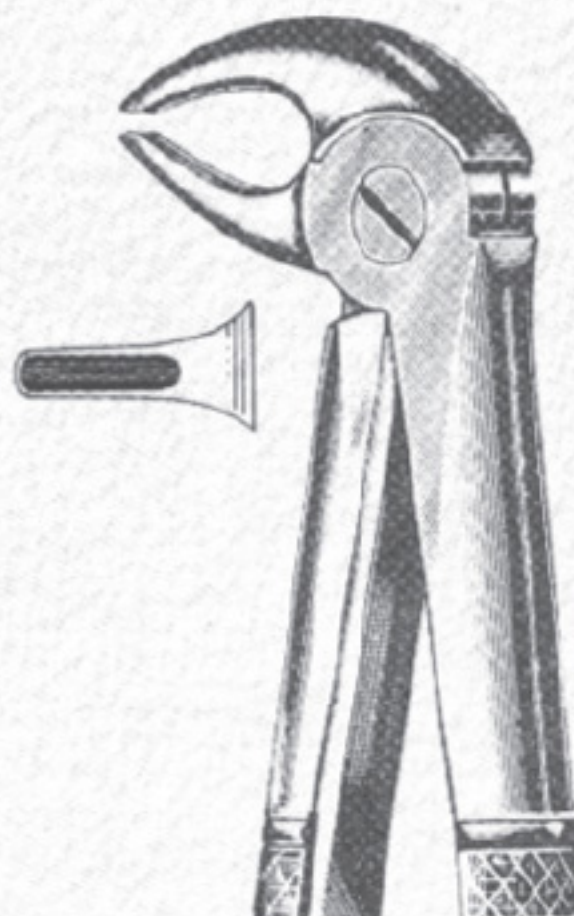

786-168
Fig. MD 3
Lower incisors, premolars
& roots

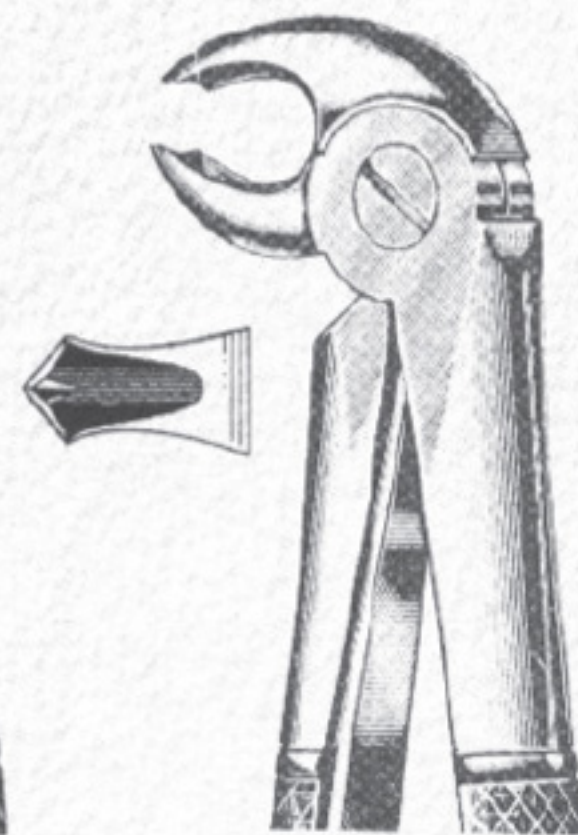

786-169
Fig. MD 4
Lower molars



Extracting Forceps Children`s Pattern

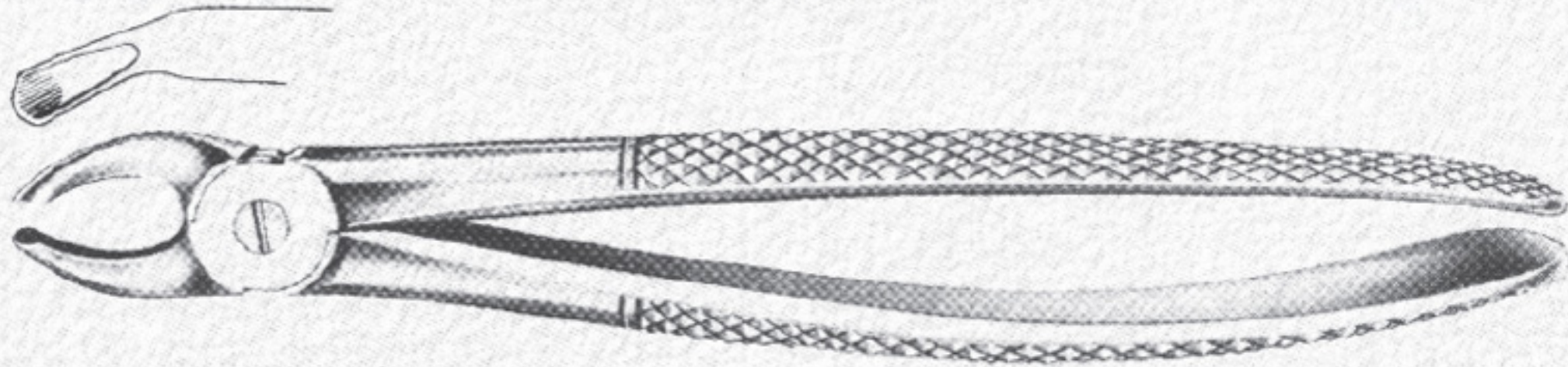

786-170
Fig. 158

Children`s upper molars universal

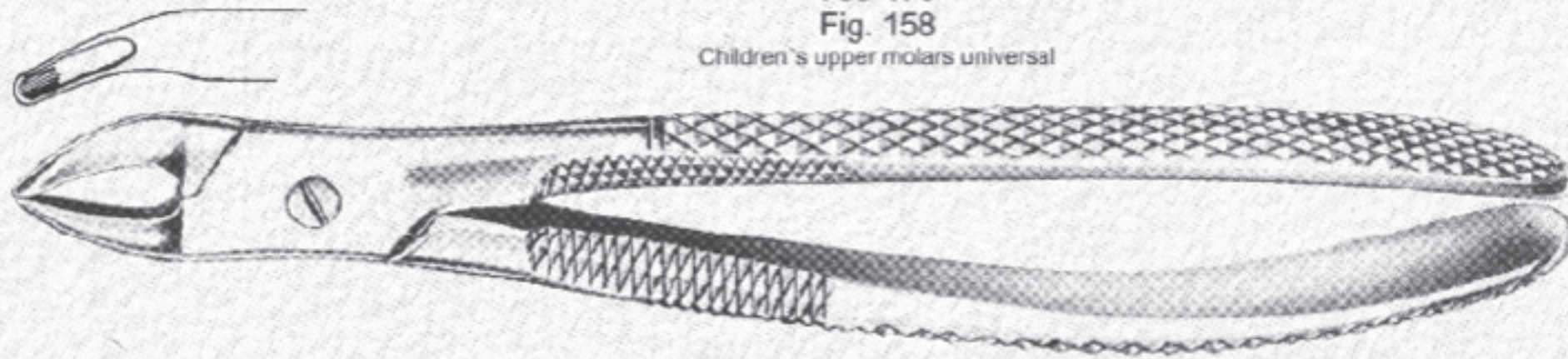

786-171
Fig. 159

Children`s upper teeth universal

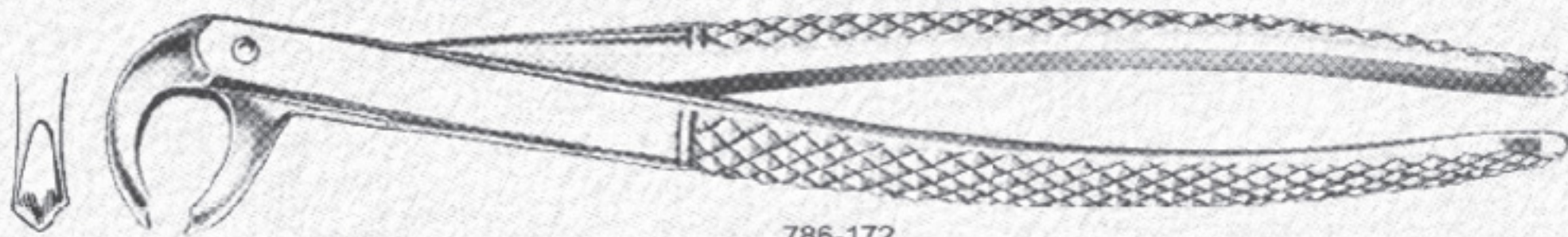

786-172
Fig. 160

Children`s lower molars universal(hawk`s bill)

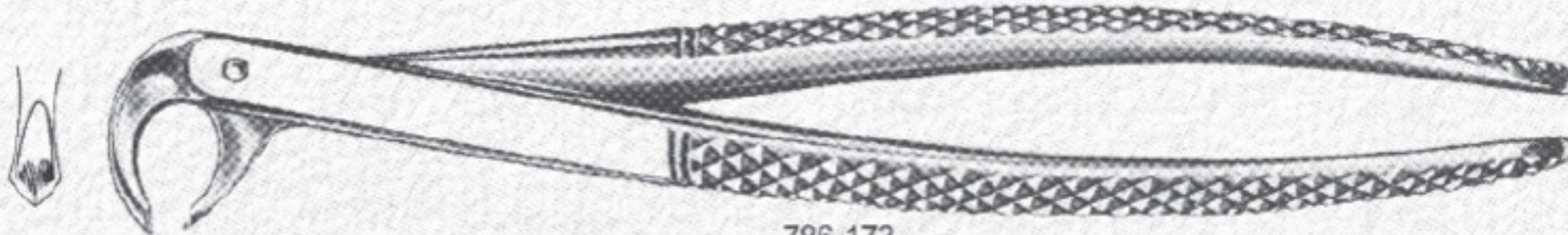

786-173
Fig. 161

Children`s lower centrals & roots

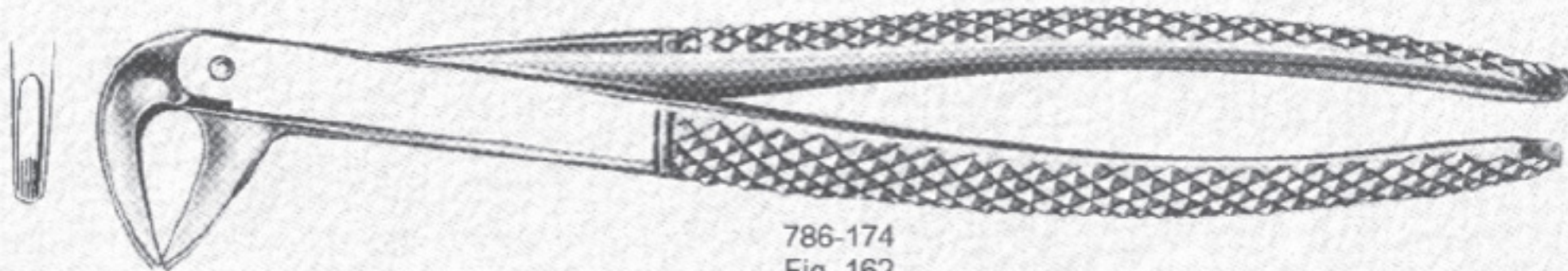

786-174
Fig. 162

Children`s upper centrals

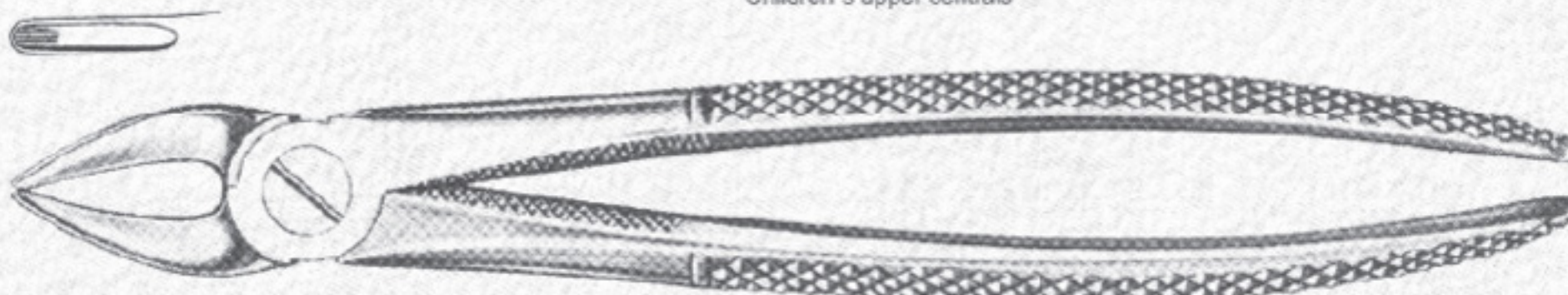

786-175
Fig. 163

Children`s upper centrals



Extracting Forceps English Pattern

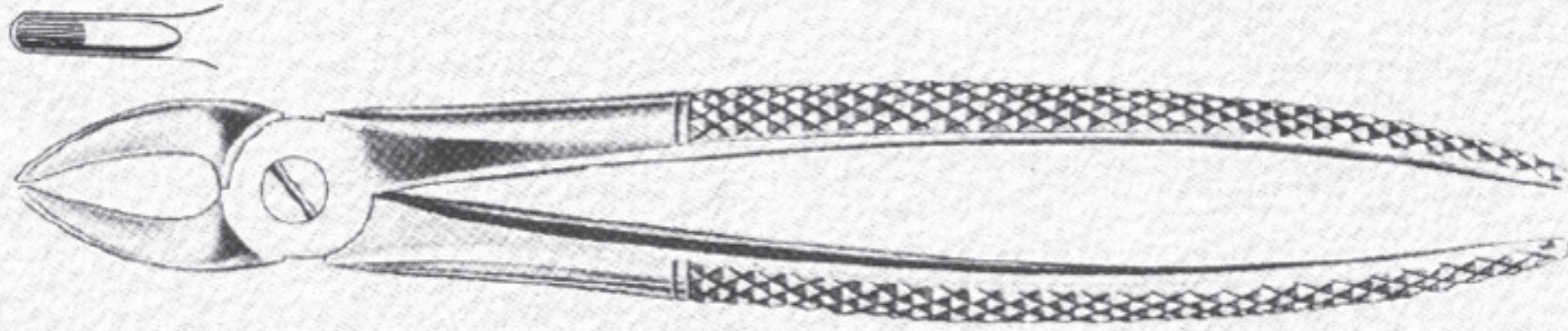

786-176
Fig. 37

Children's upper incisors & canines

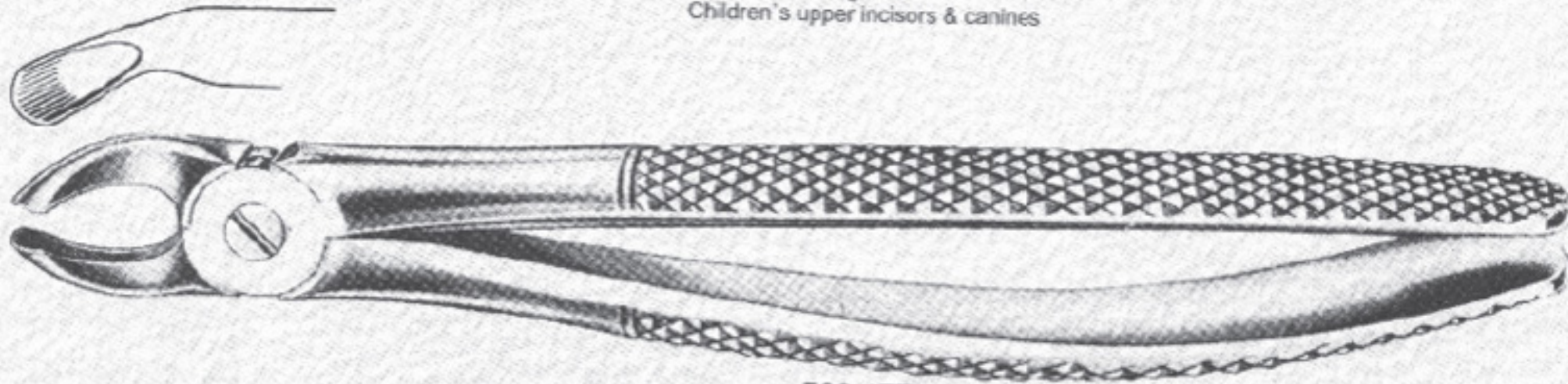

786-177
Fig. 39

Children's upper molars universal

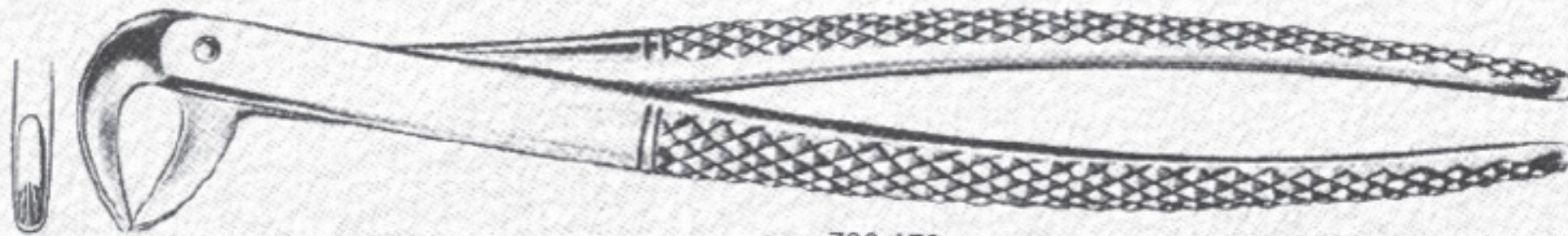

786-178
Fig. 123

Children's lower teeth universal

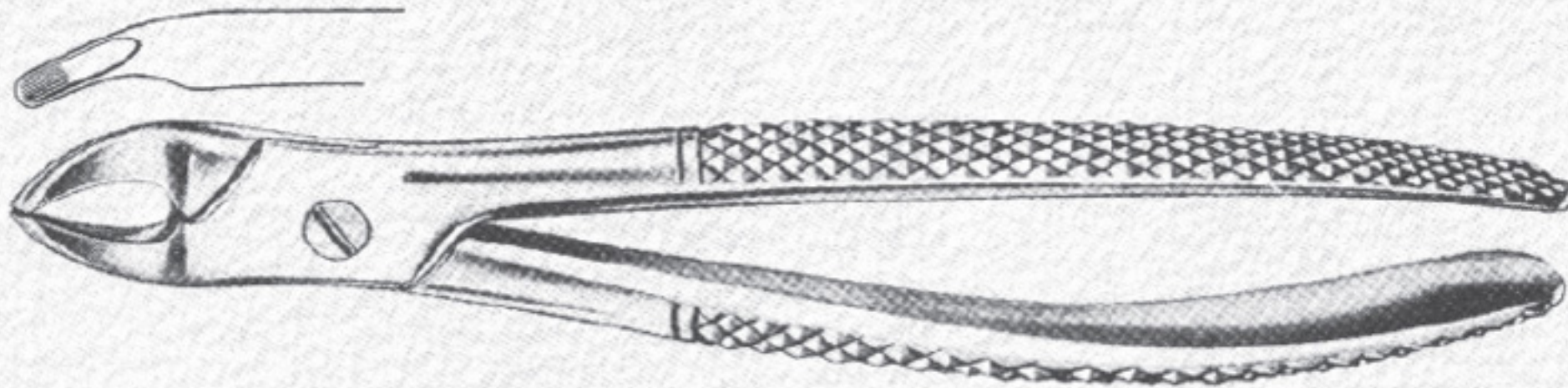

786-179
Fig. 138

Children's upper universal & roots

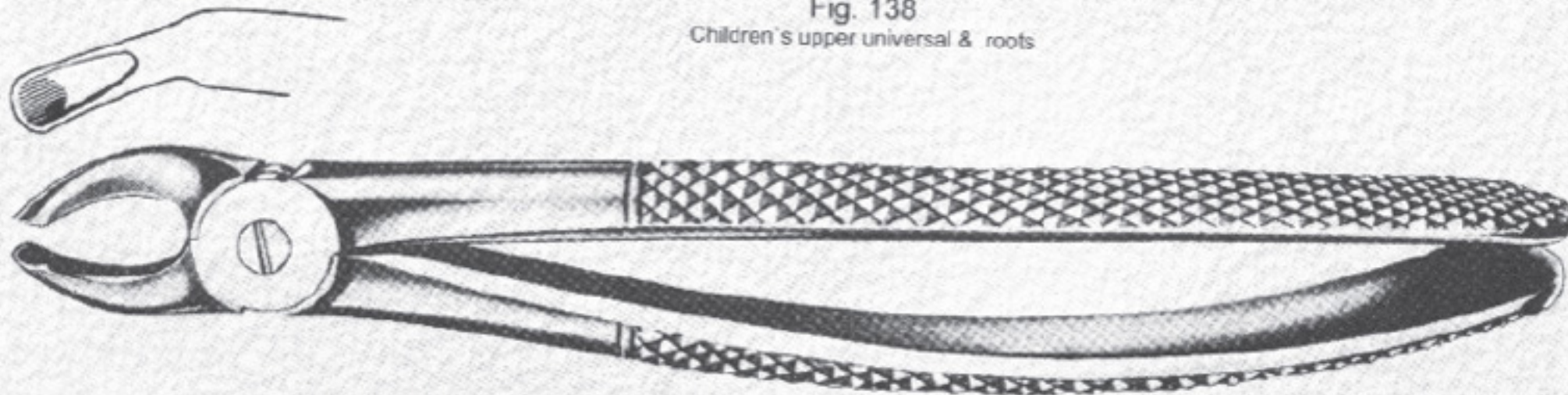

786-180
Fig. 157

Children's upper molars universal



Wisdom Teeth Extracting Forceps Root Fragment Forceps

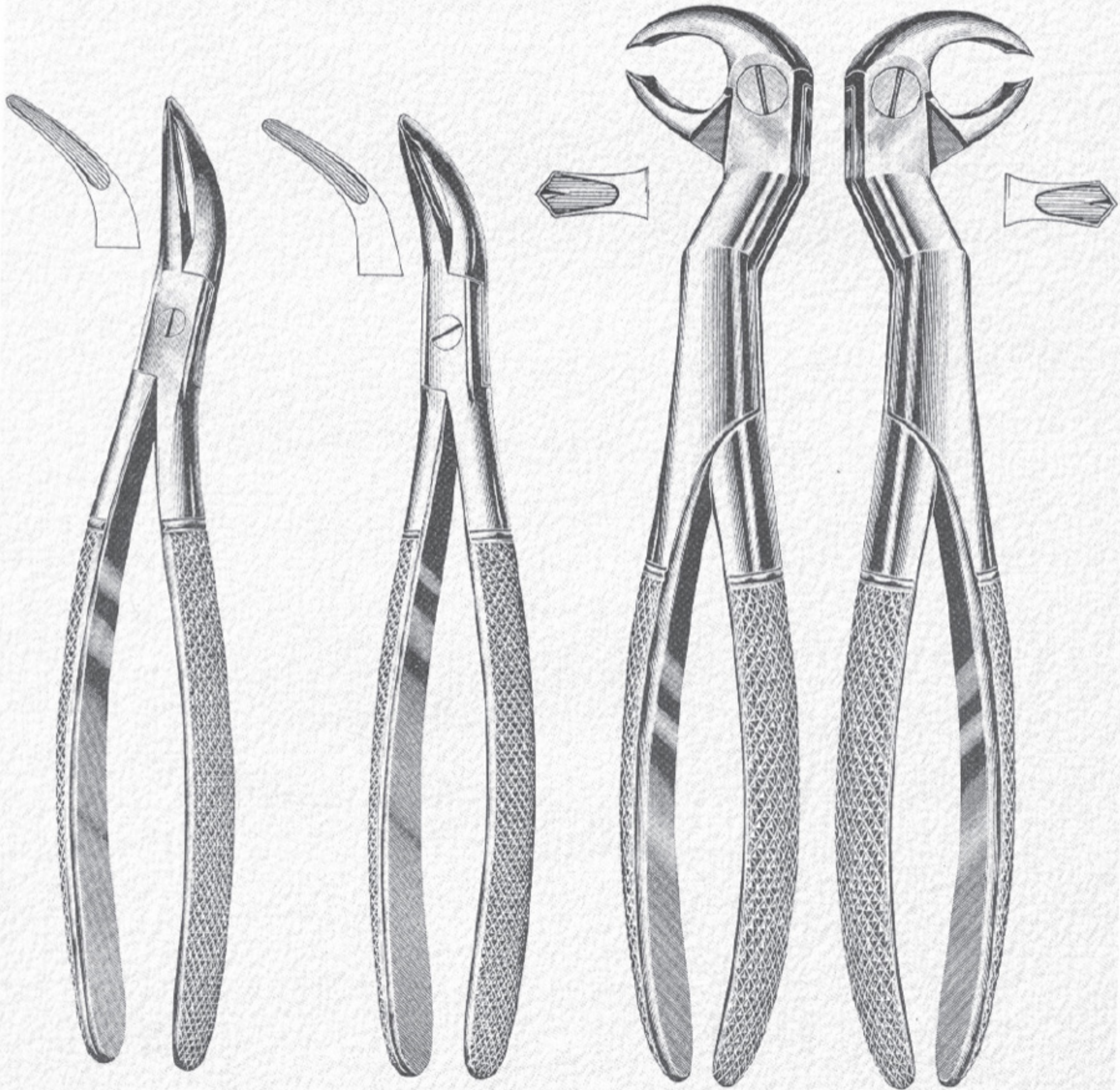

786-181
universal pattern for upper teeth

786-182
universal pattern for lower teeth

786-183
Fig. 22 1/2L
Left lower wisdoms
& molars

786-184
Fig. 22 1/2 R
Right lower wisdoms
& molars



Tooth Extracting Forceps for children`s with Spring



786-185
Fig. 3
Upper molars

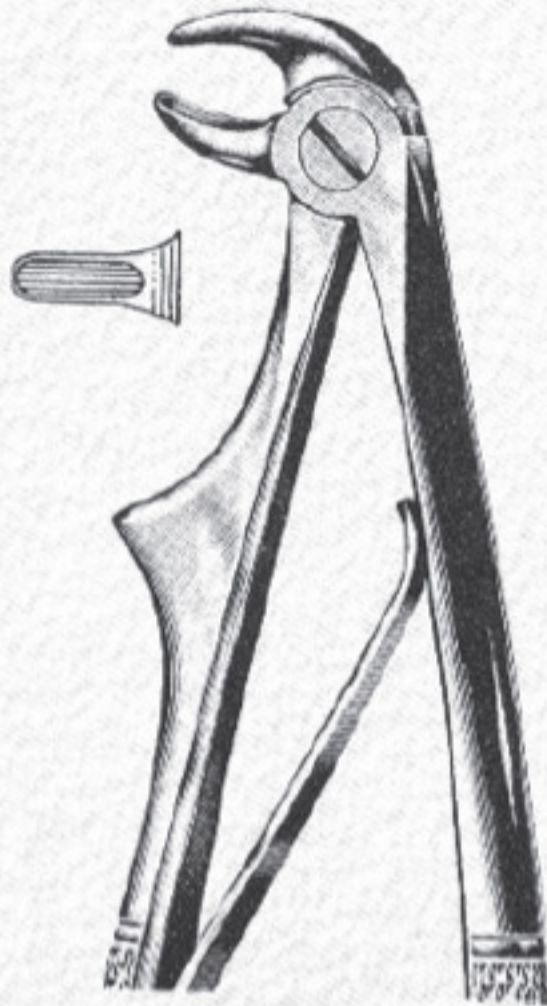

786-186
Fig. 5
Lower incisors

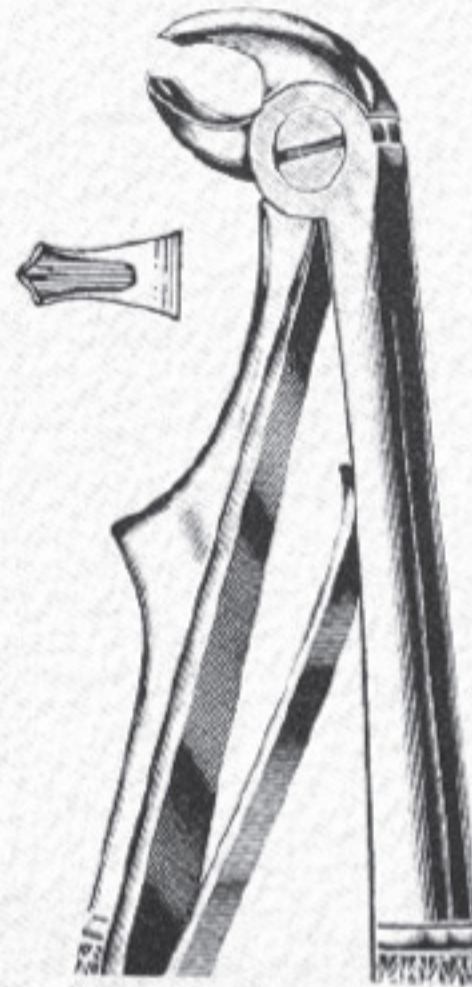

786-187
Fig. 6
Lower molars

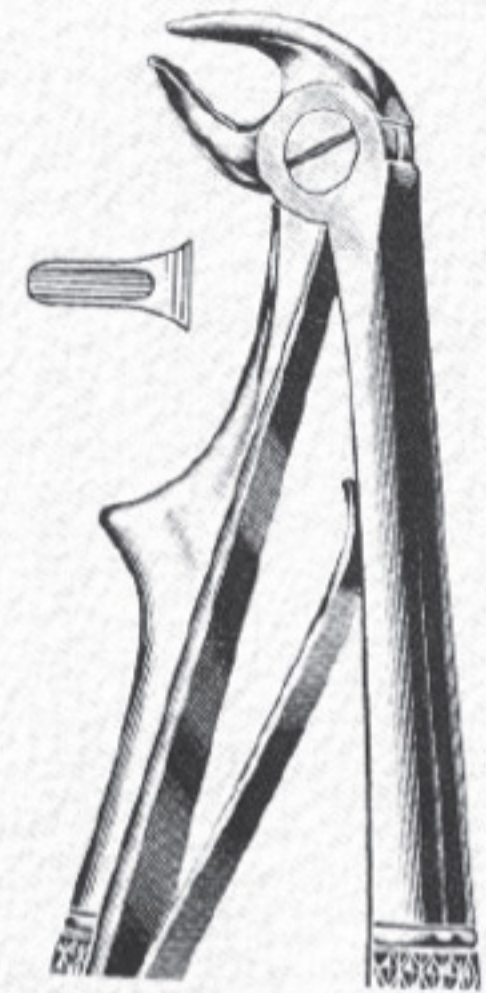

786-188
Fig. 7
Lower roots

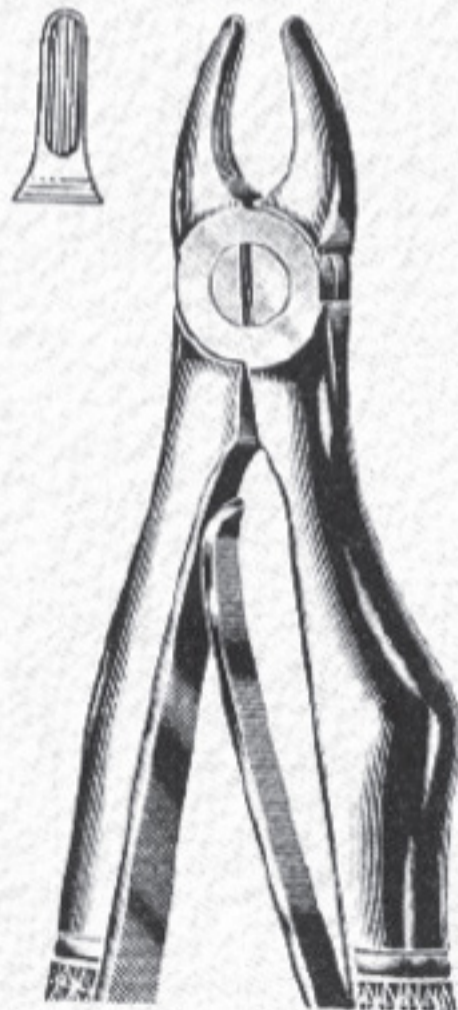

786-189
Fig. 137
Upper incisors
& canines

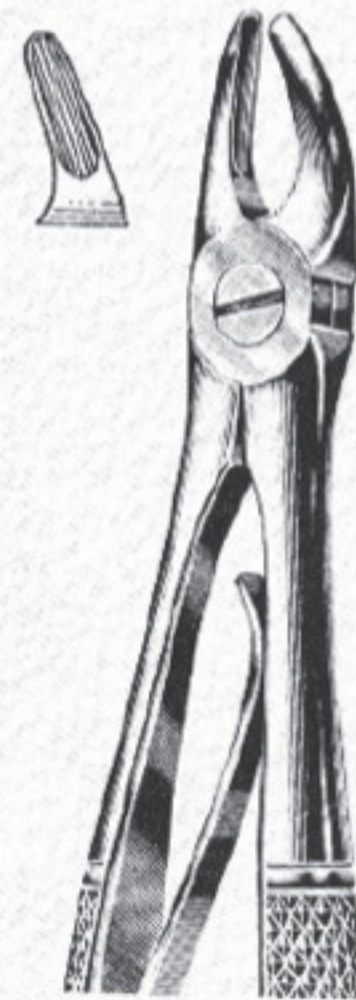

786-190
Fig. 139
Upper premolars

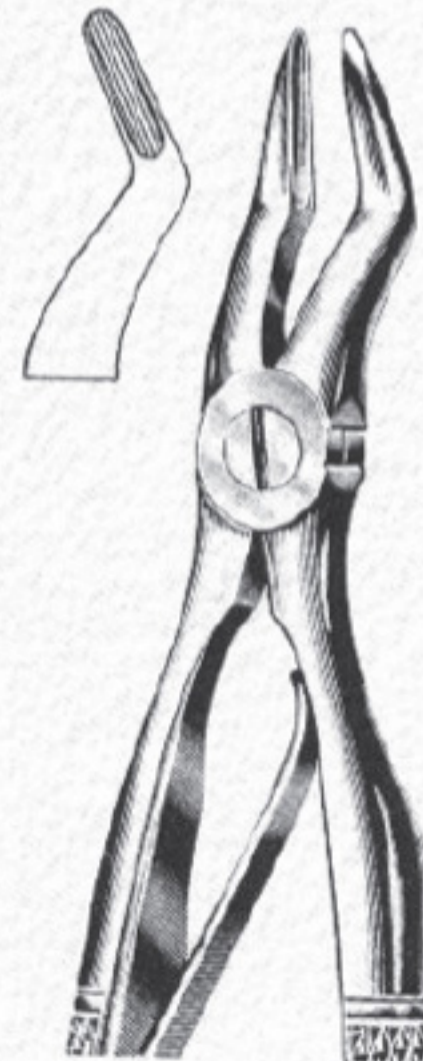

786-191
Fig. 51S
Upper roots



Tooth Extracting Forceps American Pattern

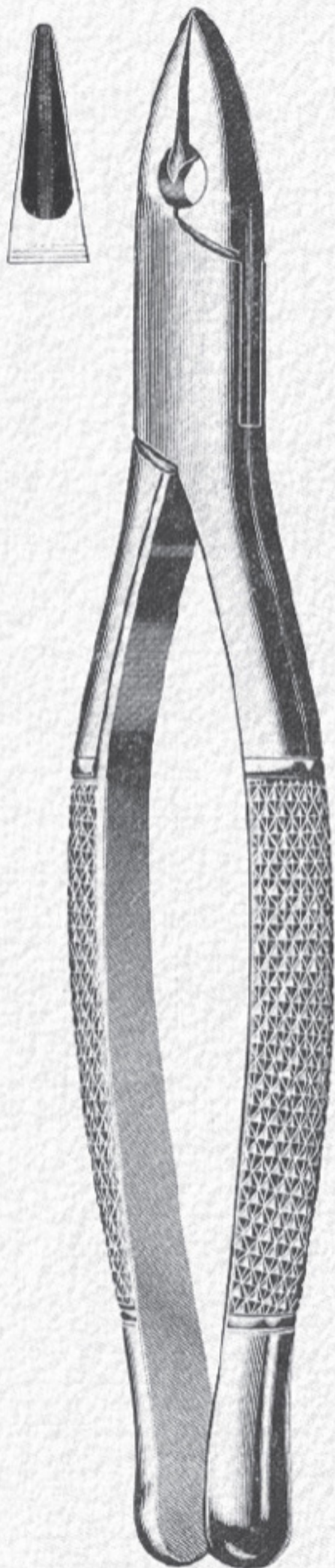

786-192
Fig. 1
Upper centrals, laterals & cuspids

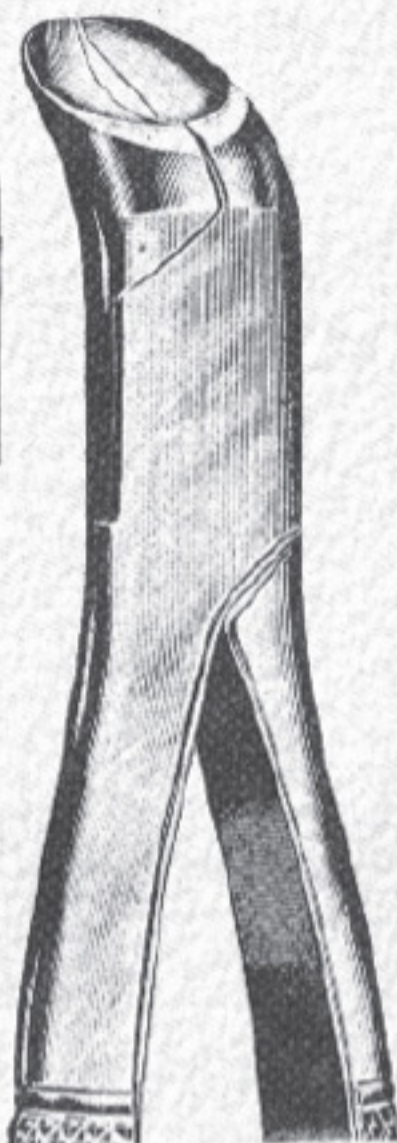
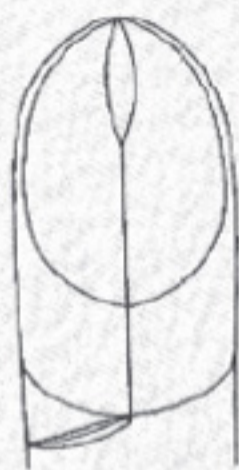

786-193
Fig. 5
Lower third molars

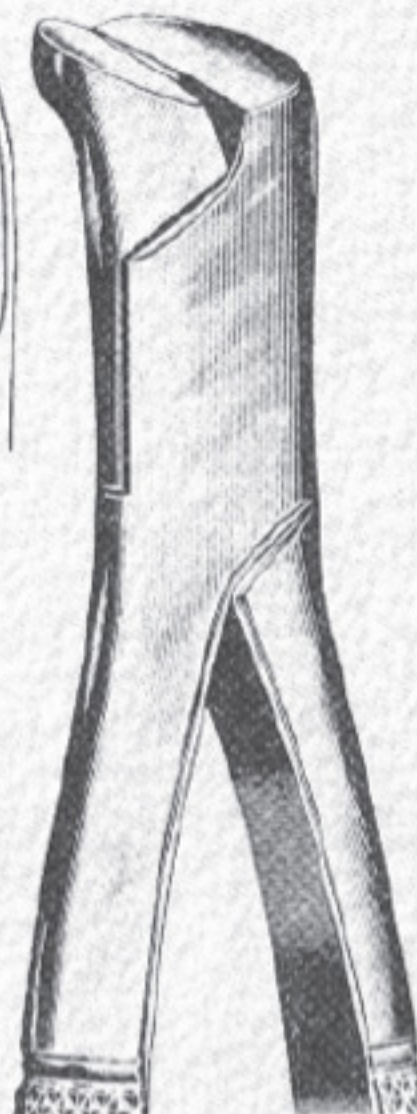
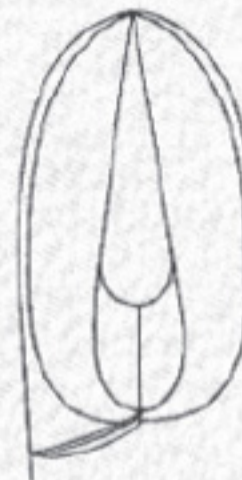

786-194
Fig. 6
Splitting forceps

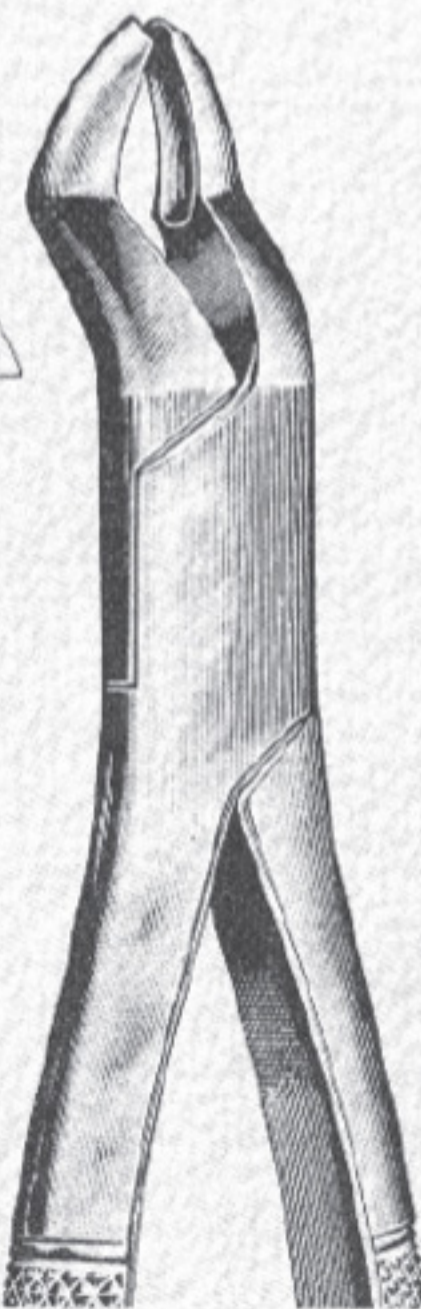

786-195
Fig. 10 H
upper molars
hook - handle



786-196
Fig. 10 S
upper molars
straight - handle

786-197
Fig. 15
Lower molars



Tooth Extracting Forceps American Pattern

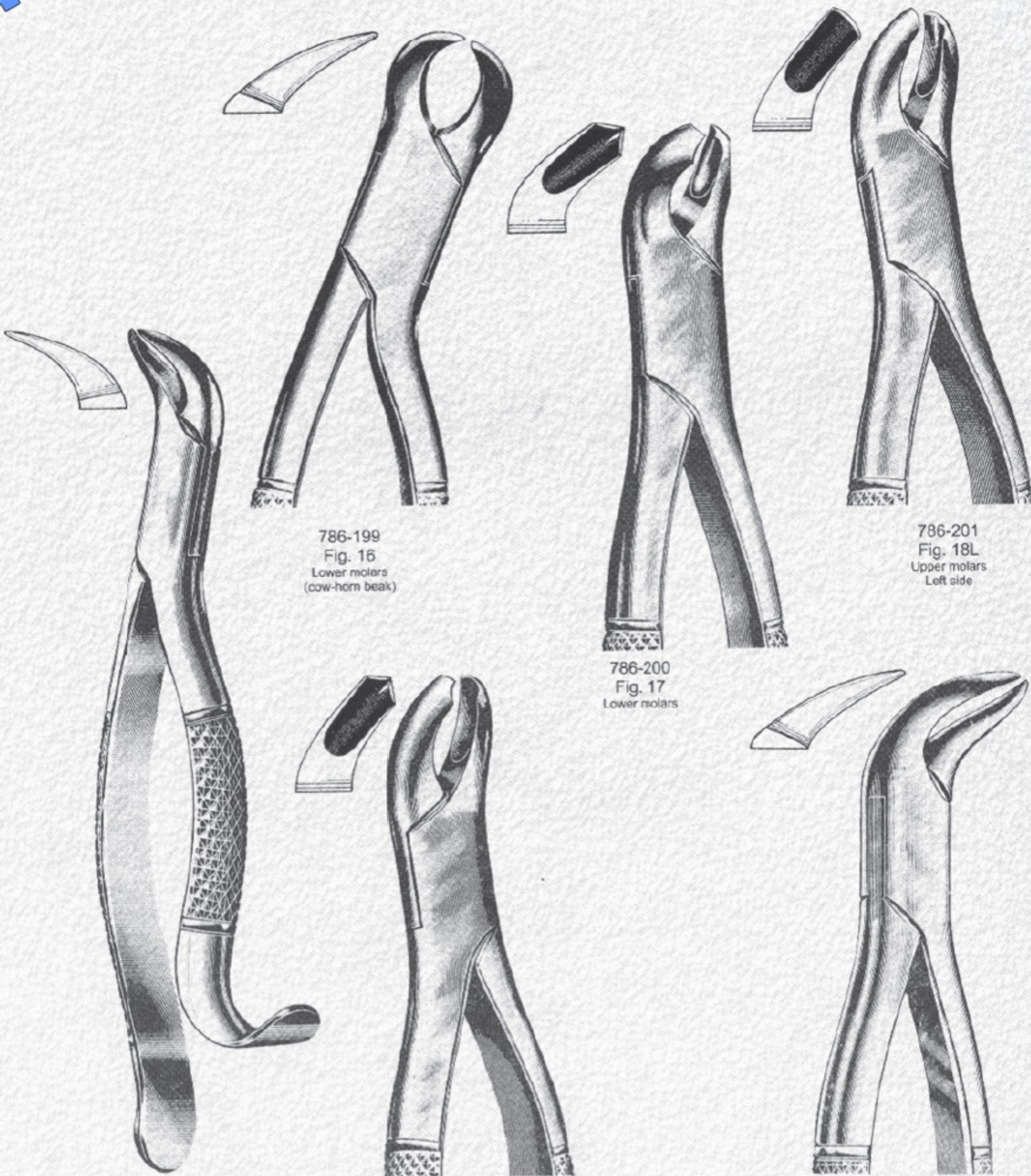

786-199
Fig. 16
Lower molars
(cow-horn beak)

786-201
Fig. 18L
Upper molars
Left side

786-200
Fig. 17
Lower molars

786-198
Fig. 16 S
Lower molars
Children

786-202
Fig. 18R
Upper molars
Right side

786-203
Fig. 23
Lower molars
(Cow-horn beak)



Tooth Extracting Forceps American Pattern

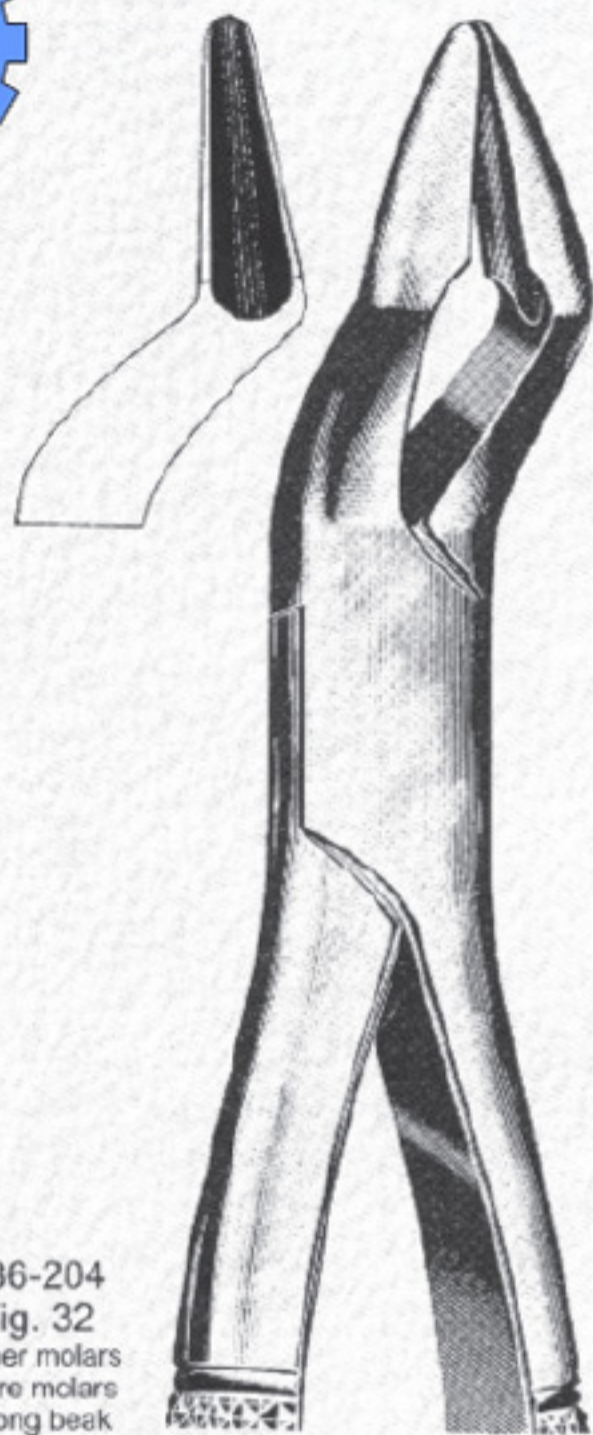

786-204
Fig. 32
Upper molars
& pre molars
strong beak

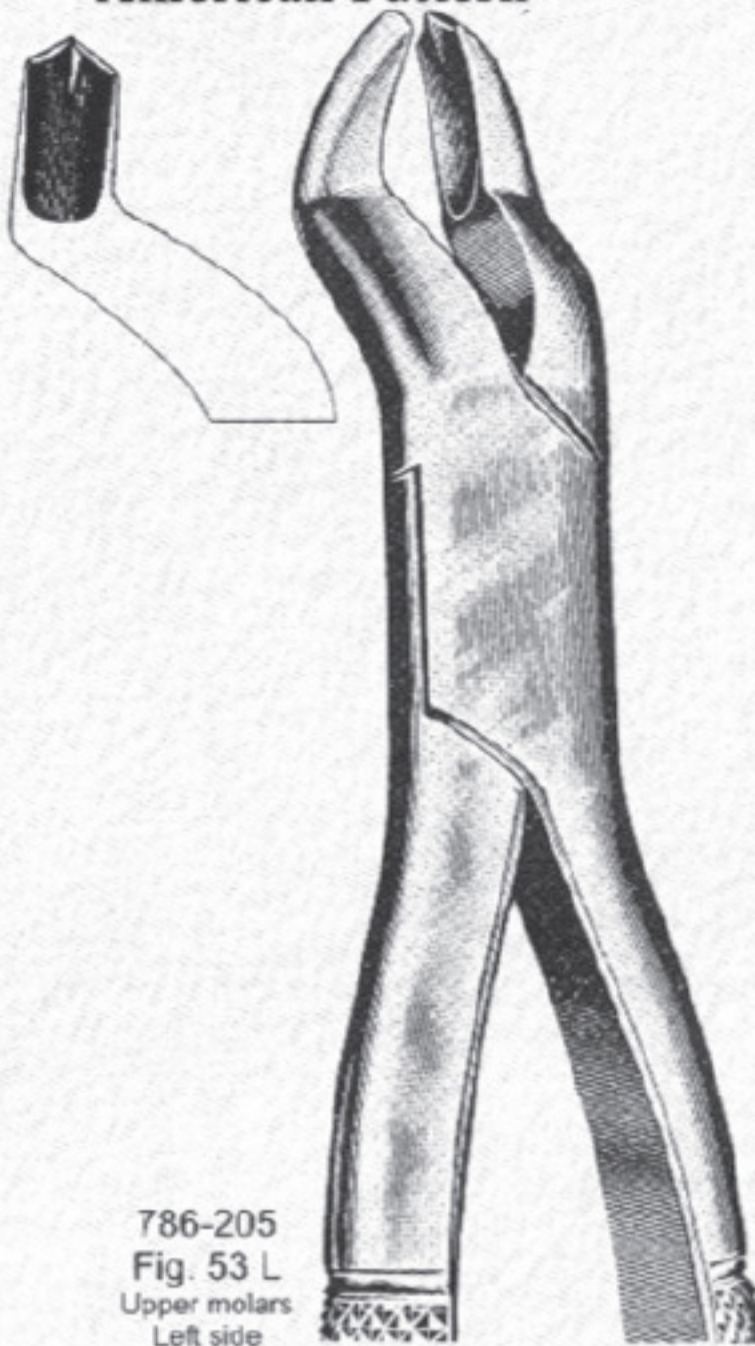

786-205
Fig. 53 L
Upper molars
Left side

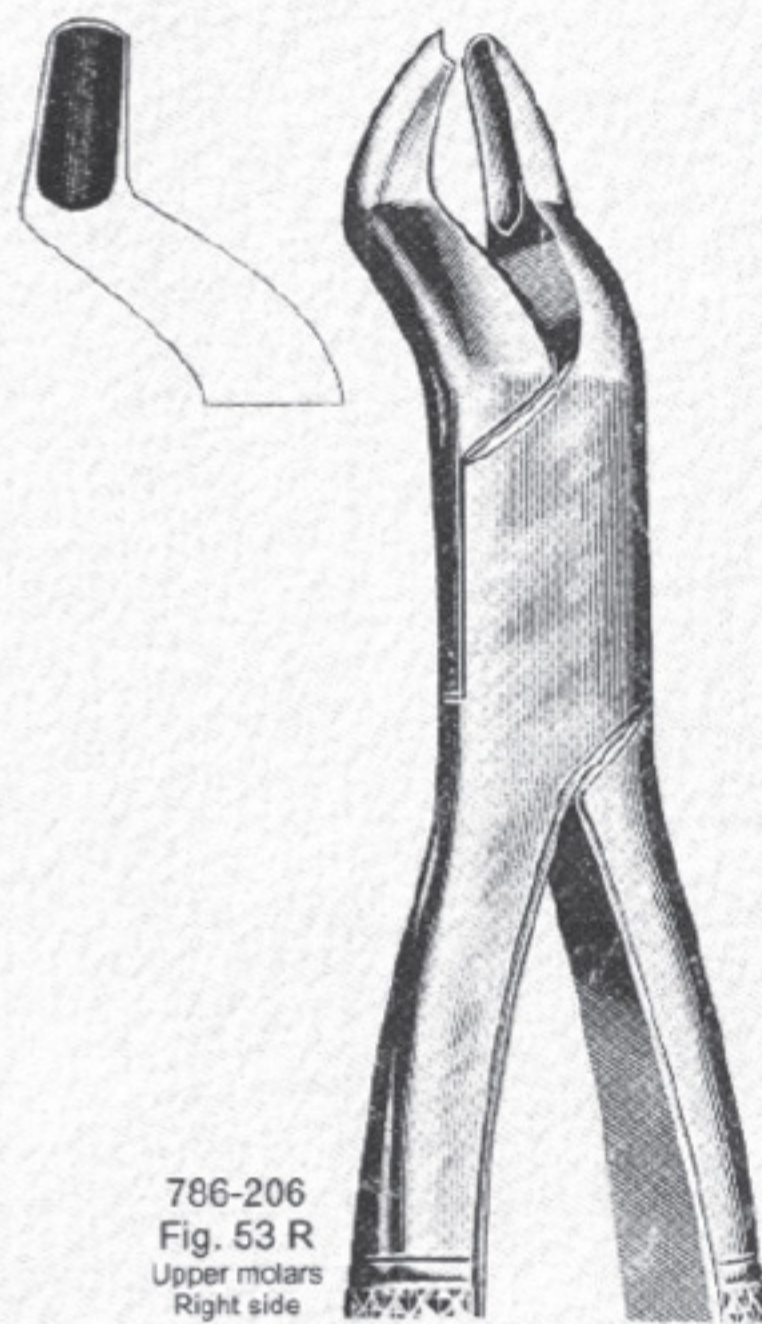

786-206
Fig. 53 R
Upper molars
Right side

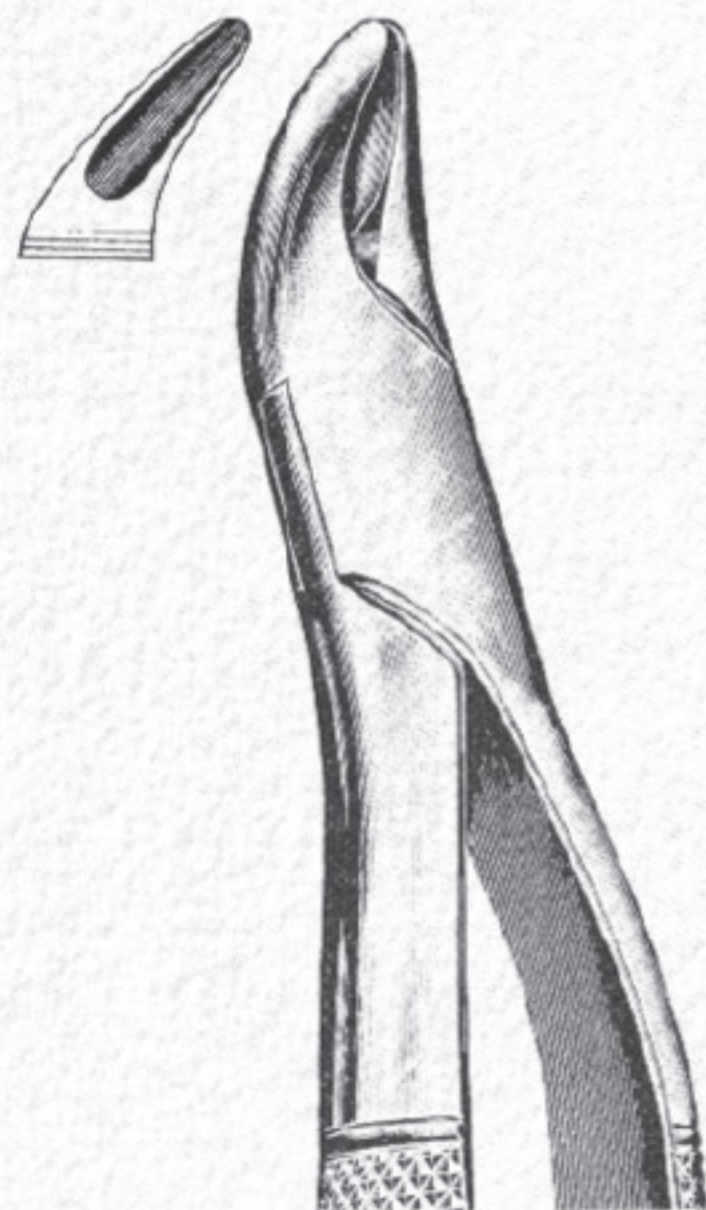

786-207
Fig. 62
Universal forceps
for upper teeth & roots

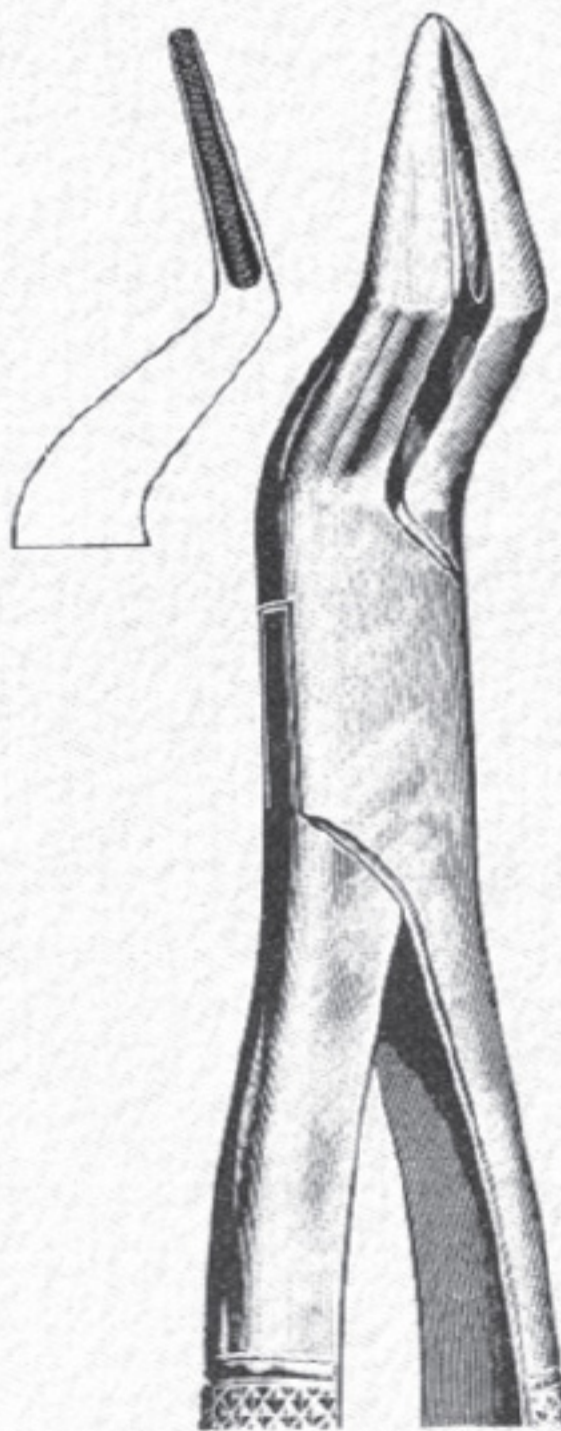

786-208
Fig. 65
upper incisors & root



786-209
Fig. 69
Fragments & small roots
Upper & Lower



Tooth Extracting Forceps American Pattern

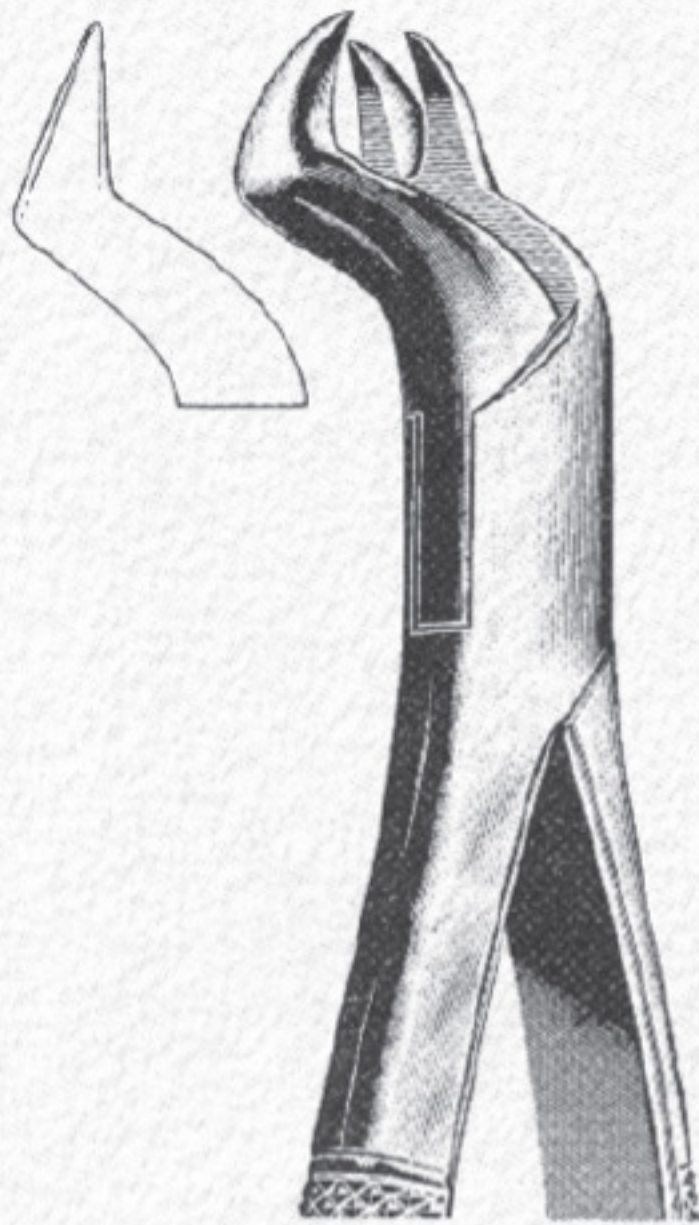

786-210
Fig. 88R
Right upper molars

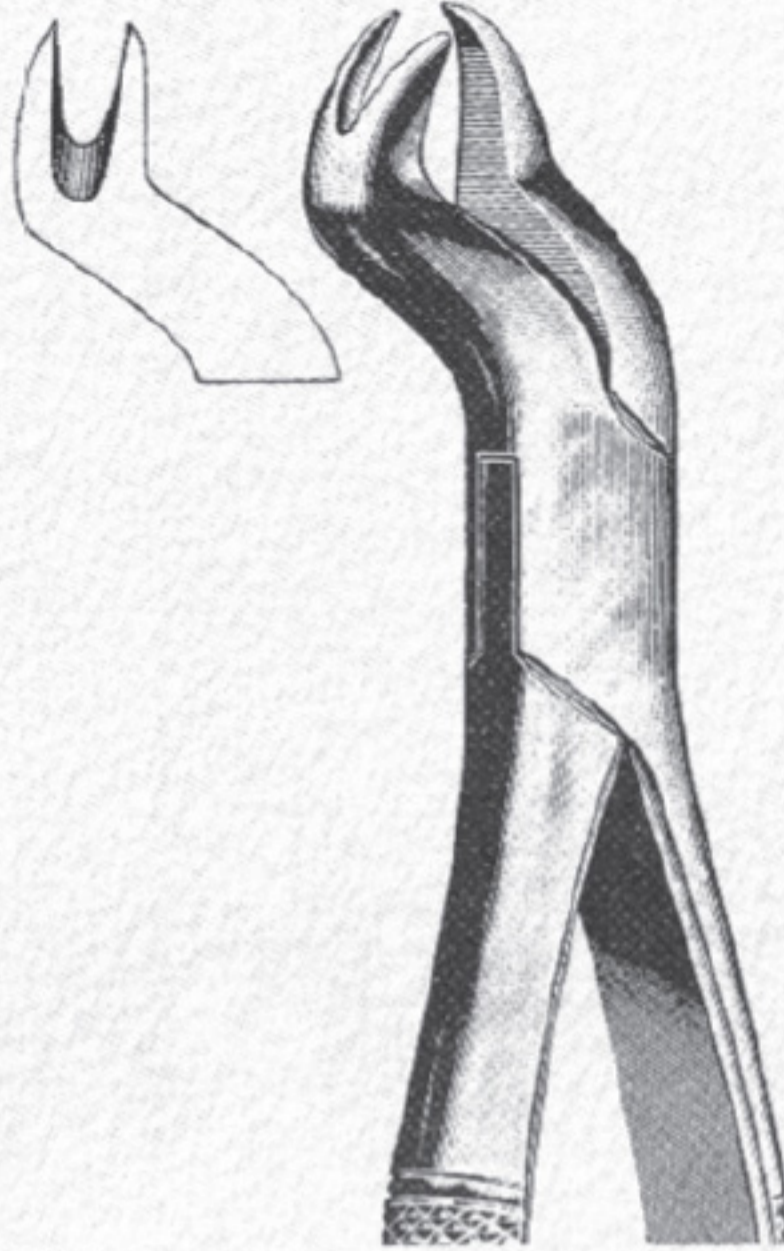

786-211
Fig. 88L
Left upper molars

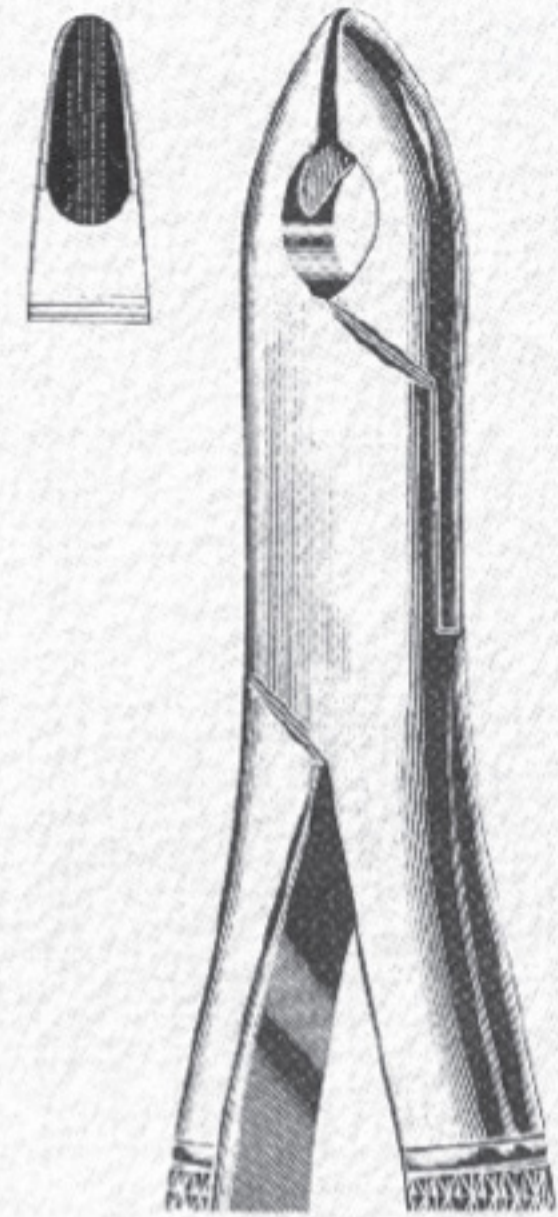

786-212
Fig. 99C
upper premolars,
molar & incisors

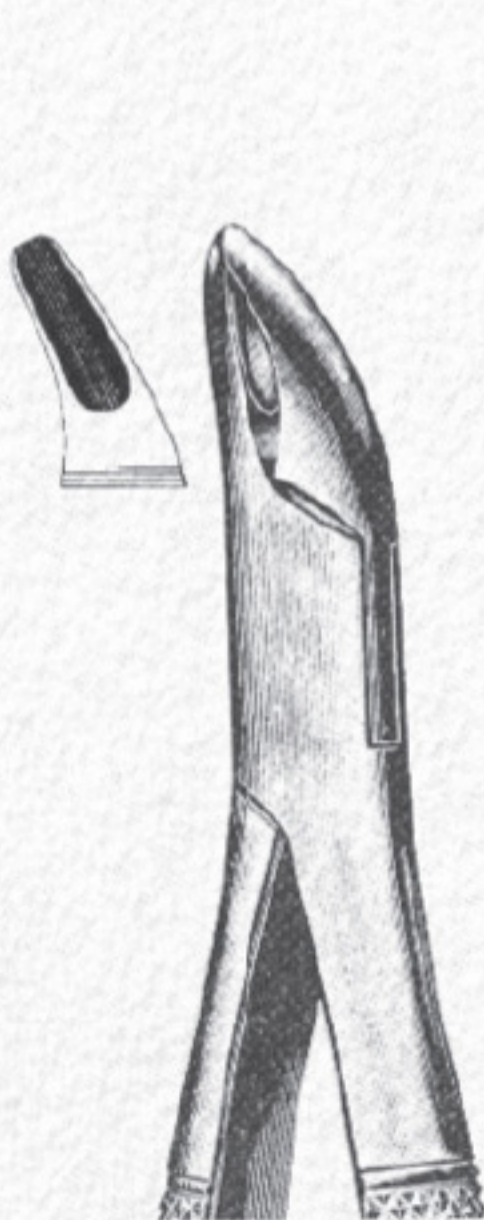

786-213
Fig. 101
Universal forceps
for premolars.



786-214
Fig. 150
Upper premolars,
incisors & roots

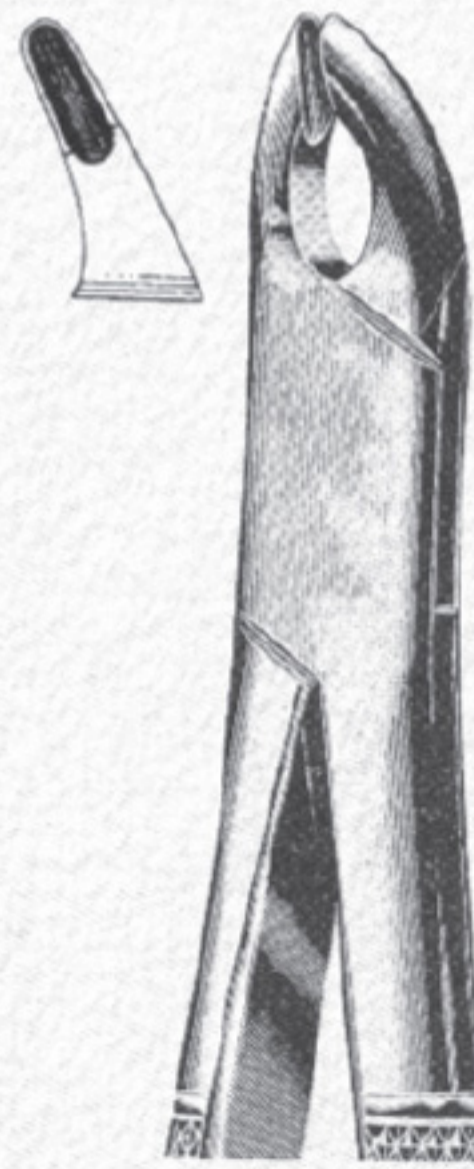

786-215
Fig. 150A
Upper premolars,
incisors & roots

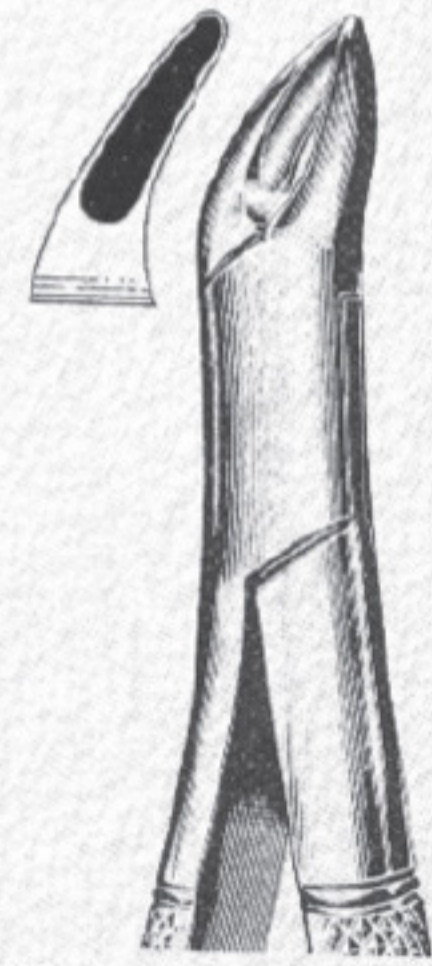

786-216
Fig. 150S
Upper premolars,
incisors & roots
for children



Tooth Extracting Forceps American Pattern

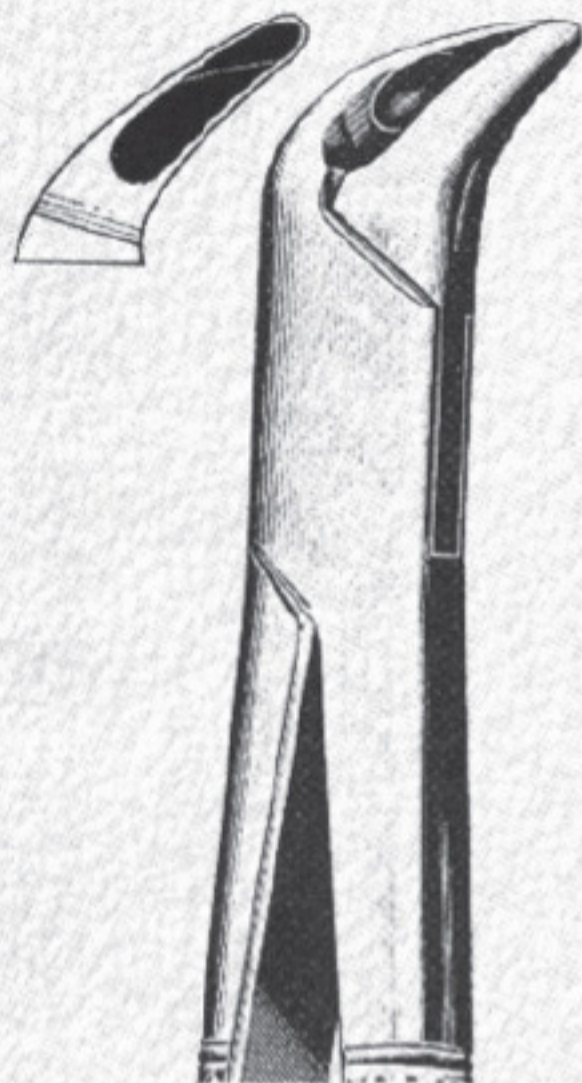

786-217
Fig. 151
Lower premolars, incisors & roots

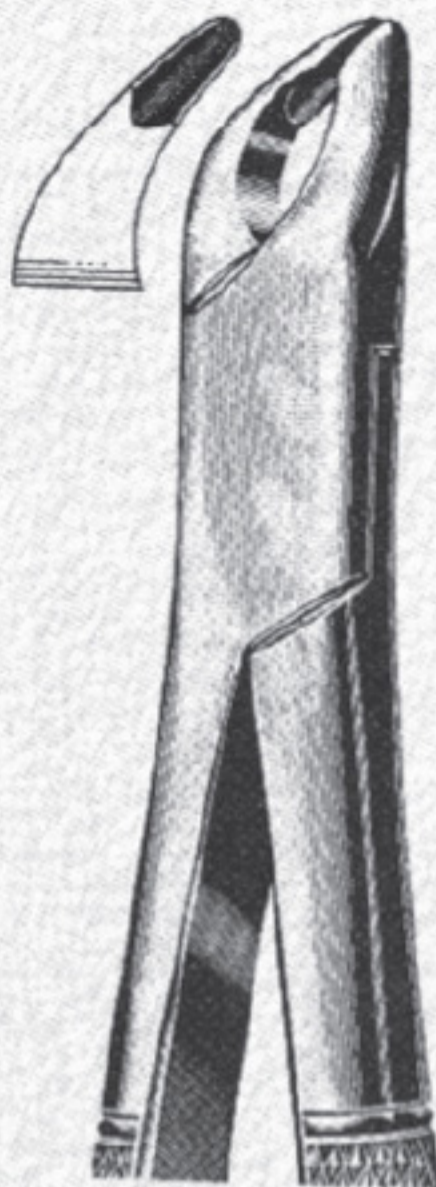

786-218
Fig. 151A
Lower premolars, incisors & roots

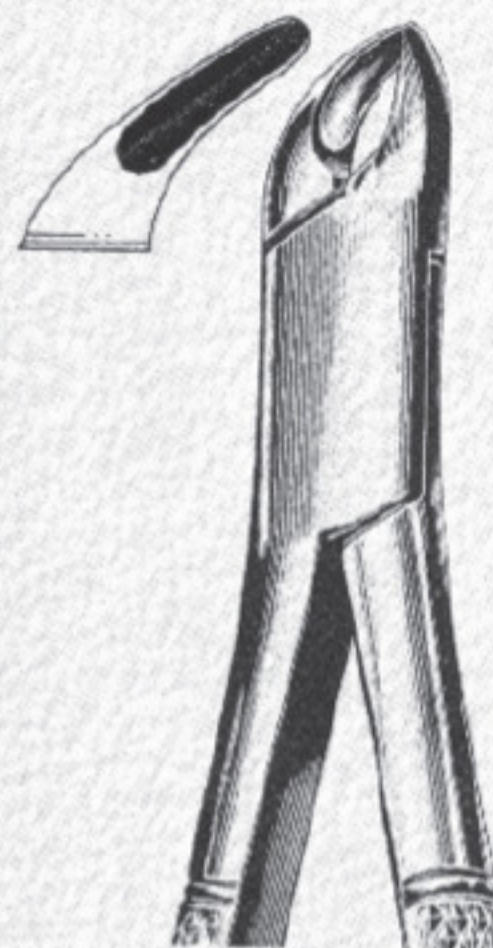

786-219
Fig. 151S
Lower premolars, incisors & roots
for children

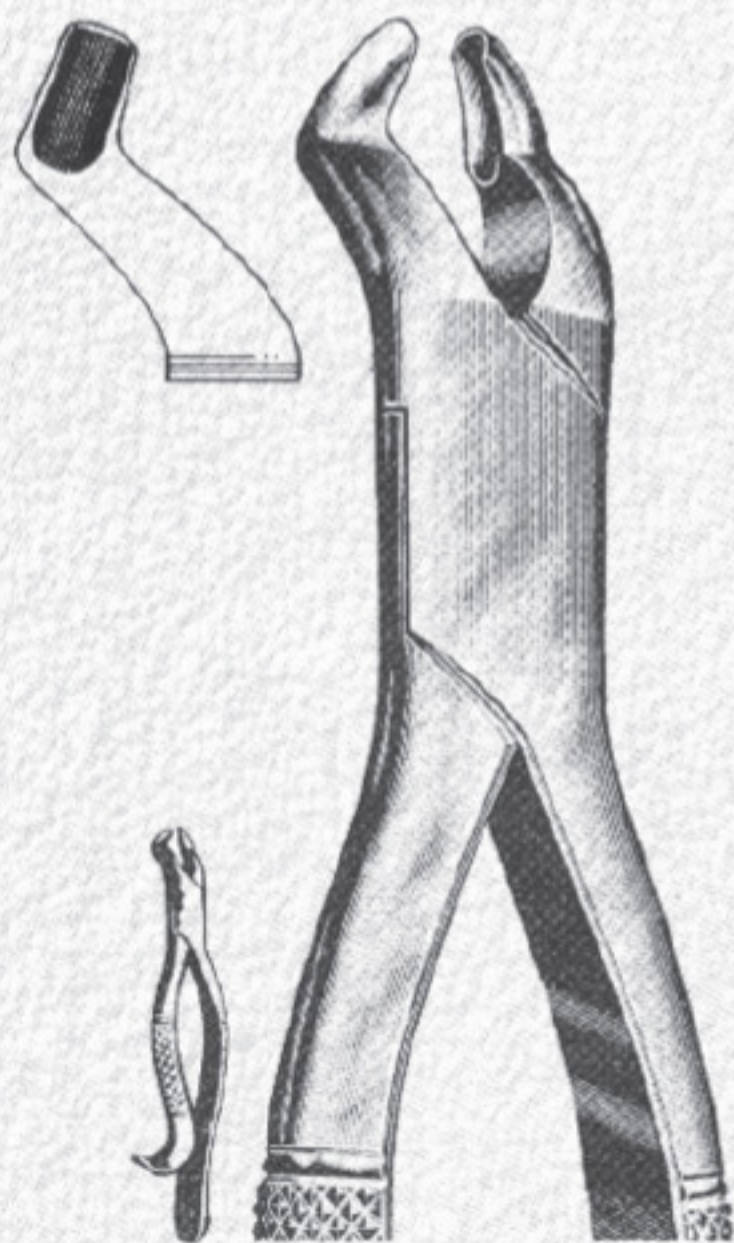

786-220
Fig. 210H
Upper wisdoms
with hook handle

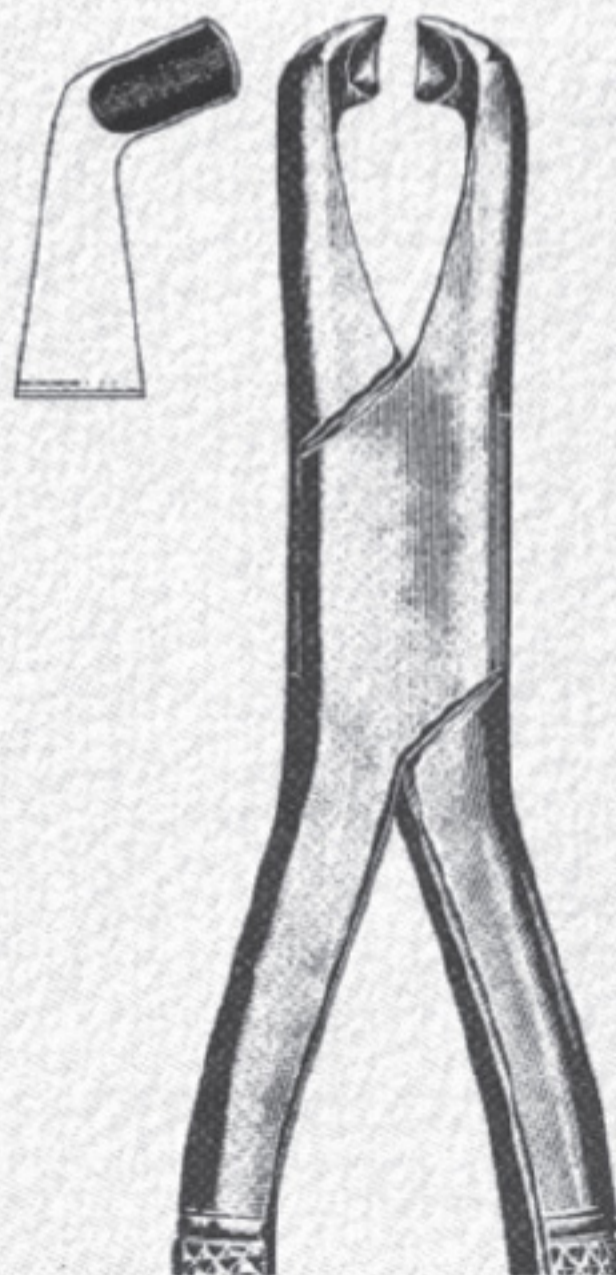

786-221
Fig. 210S
Upper wisdoms
with straight handle

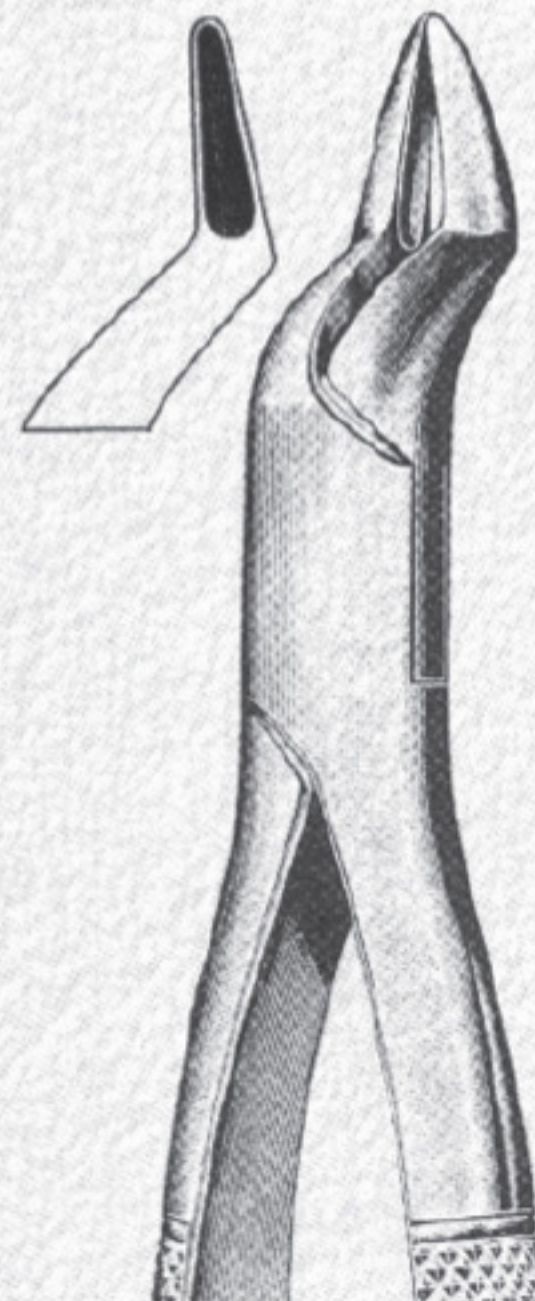

786-222
Fig. 222
Lower wisdoms

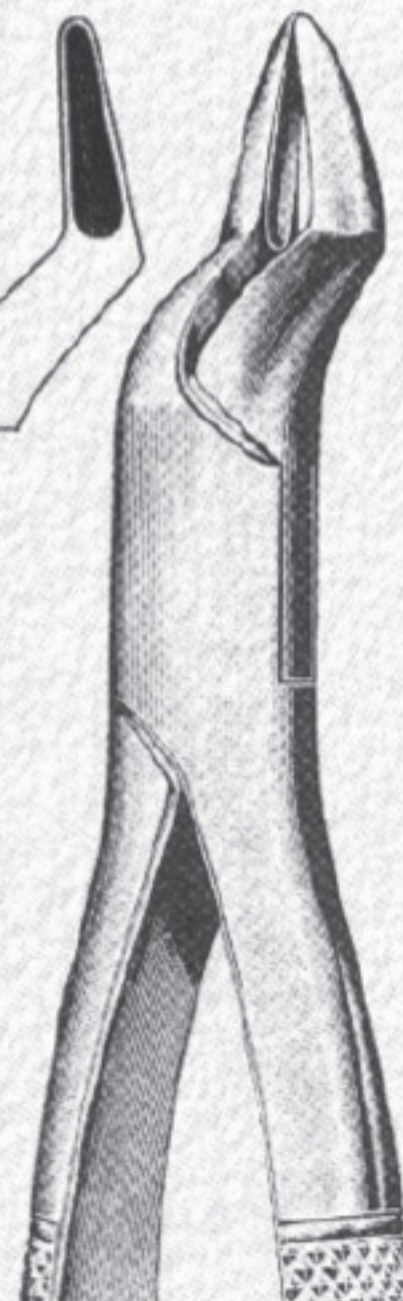

786-223
Fig. 286
Upper roots, premolars & incisors



Root Splinter Forceps Extraction Tweezer

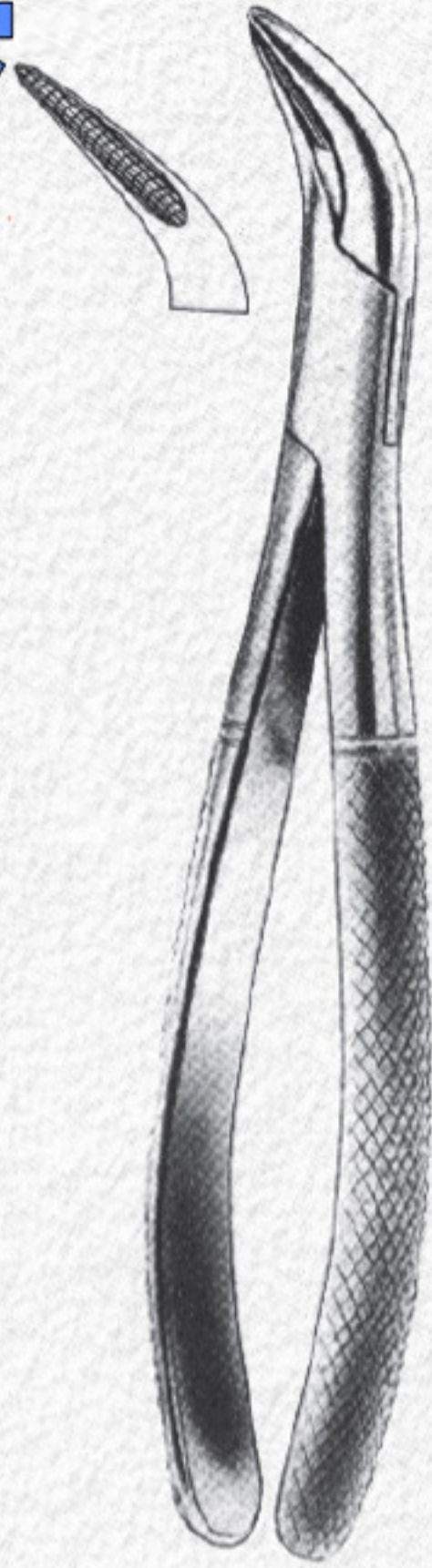

786-224
Fig. 1
Lower roots



786-225
Fig. 2
Upper roots



786-226
Albrecht
16 cm

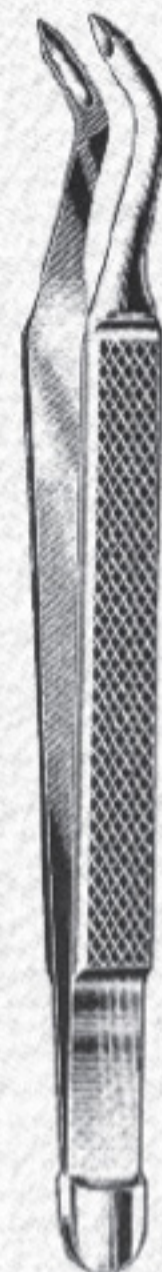

786-227
Albrecht
16 cm

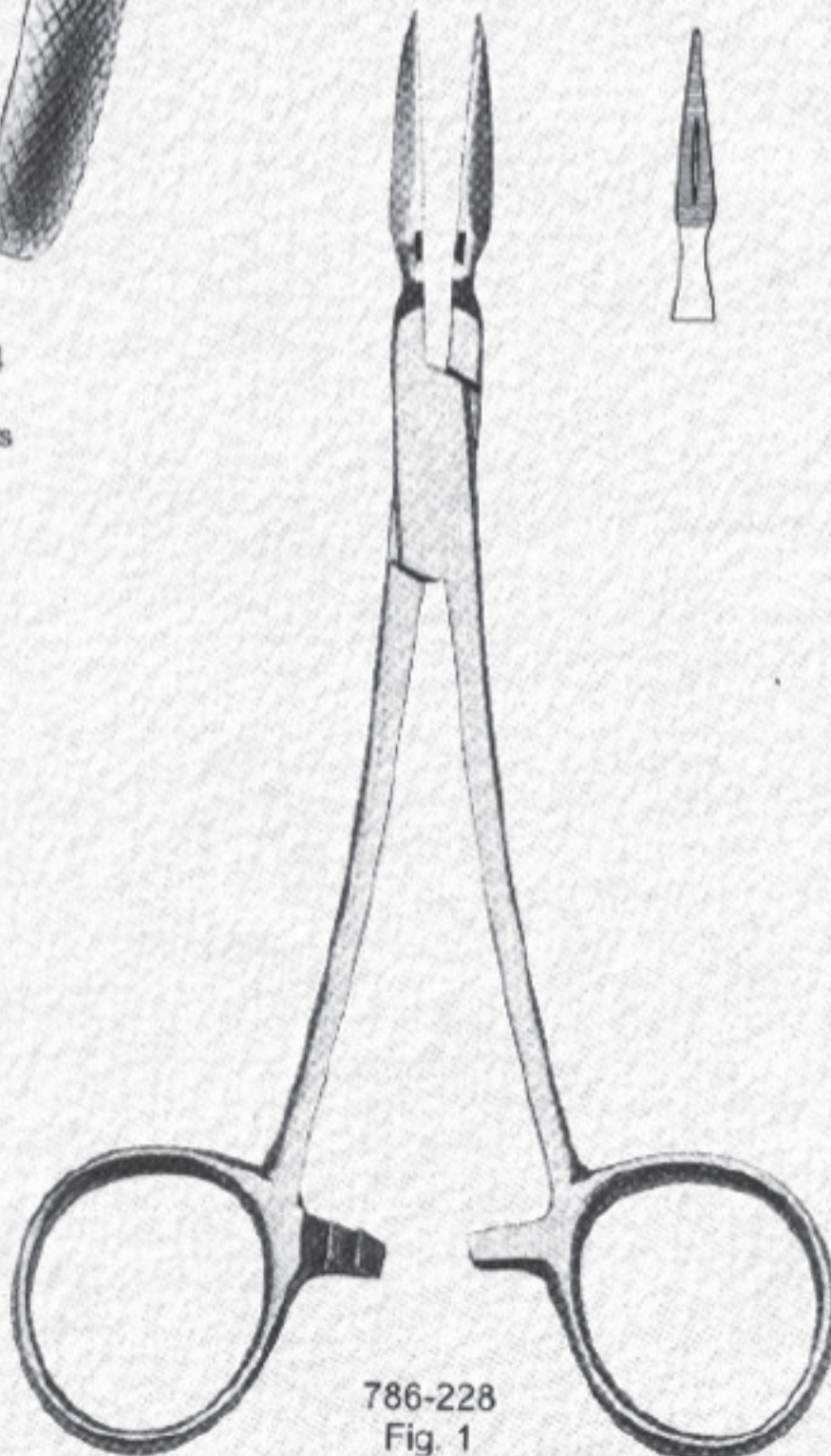

786-228
Fig. 1
Root Fragments

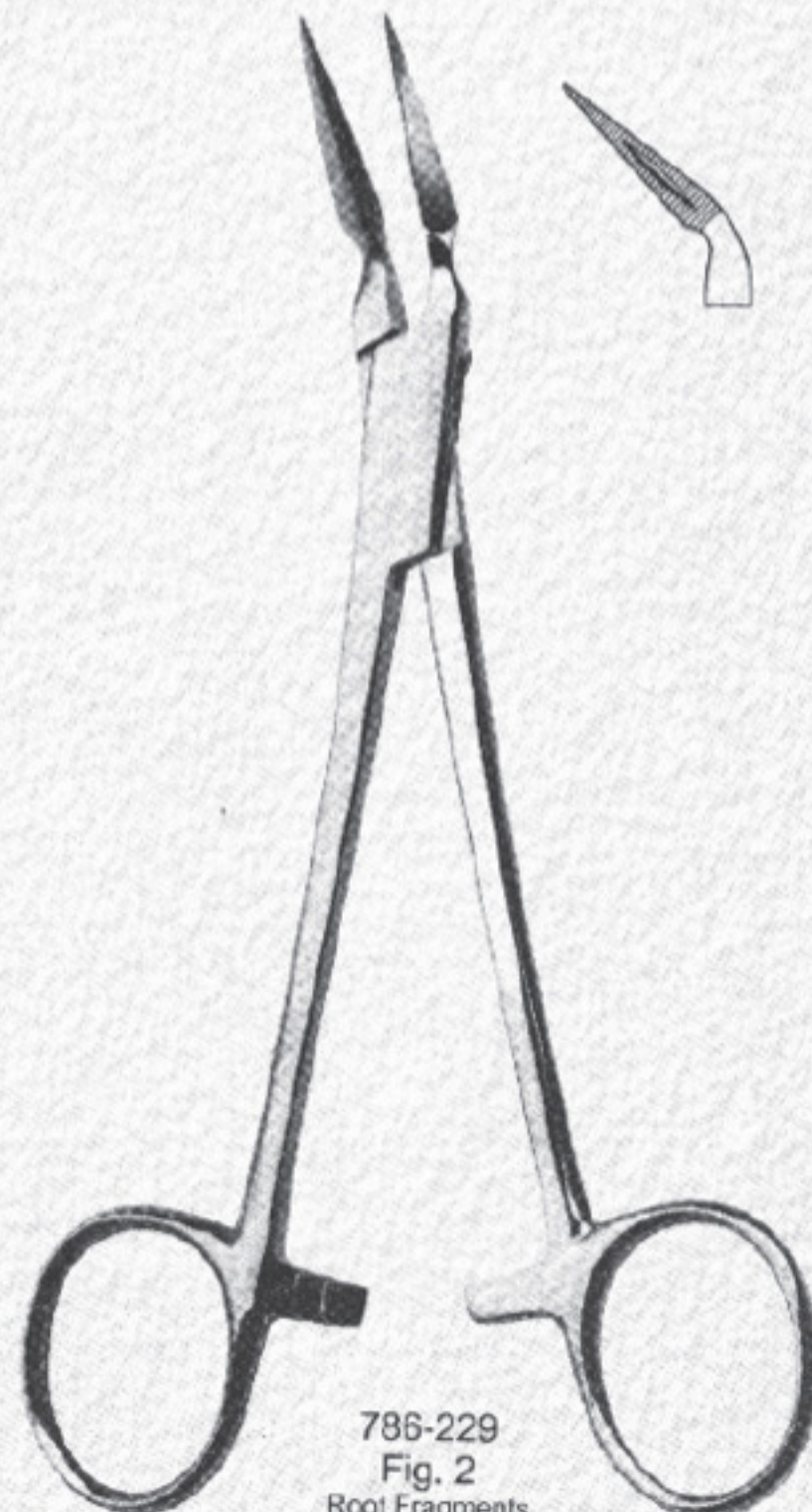

786-229
Fig. 2
Root Fragments



Bone Rongeurs

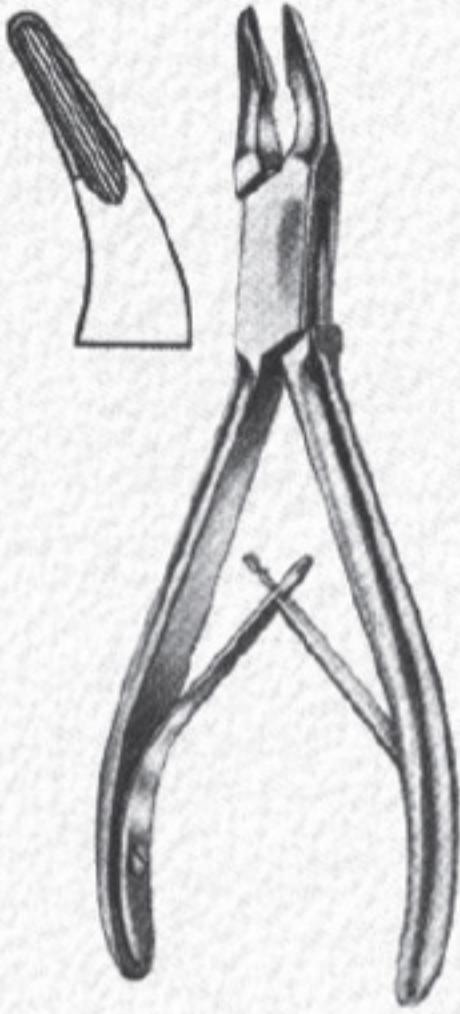

786-230
Blumenthal
15 cm

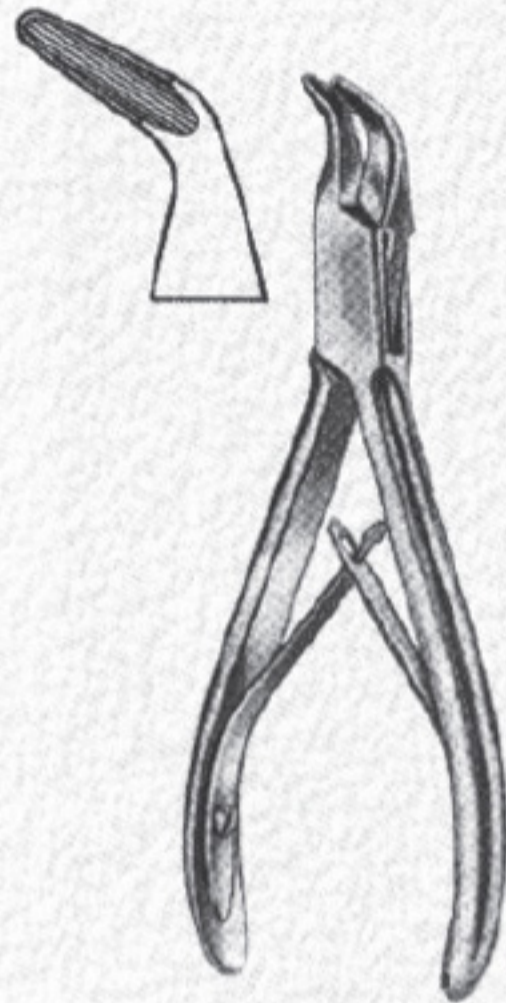

786-231
Blumenthal 45°
14,5 cm

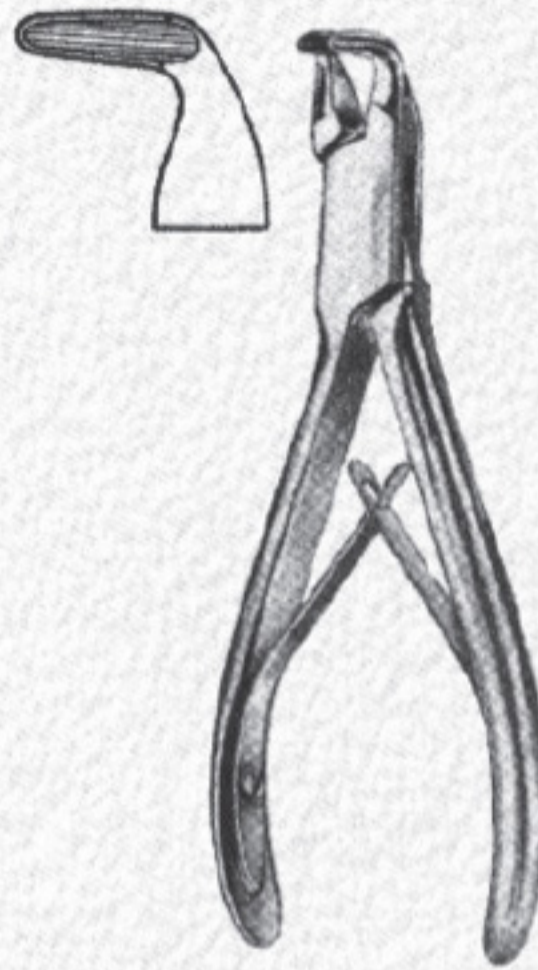

786-232
Blumenthal 90°
14 cm

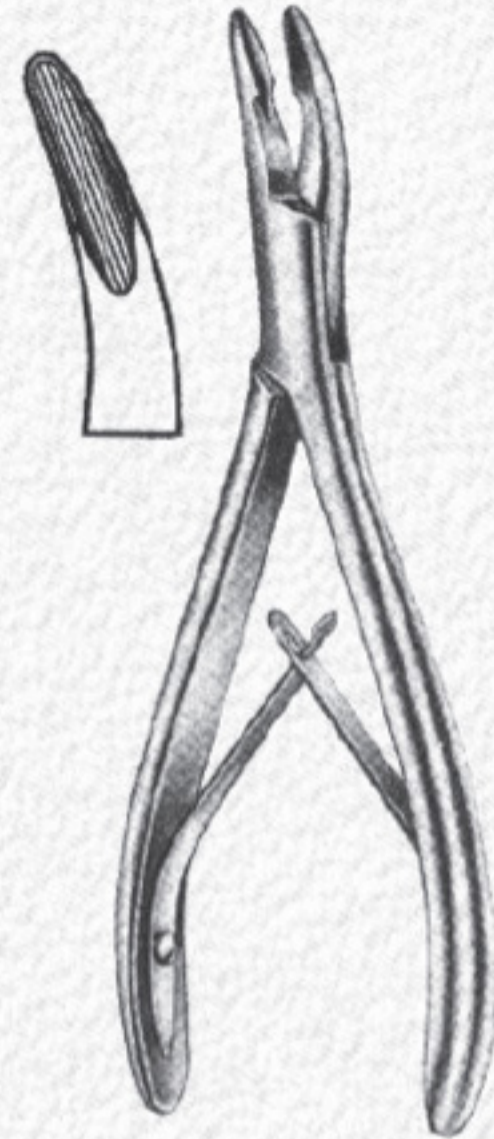

786-233
Mead 1A
16,5 cm

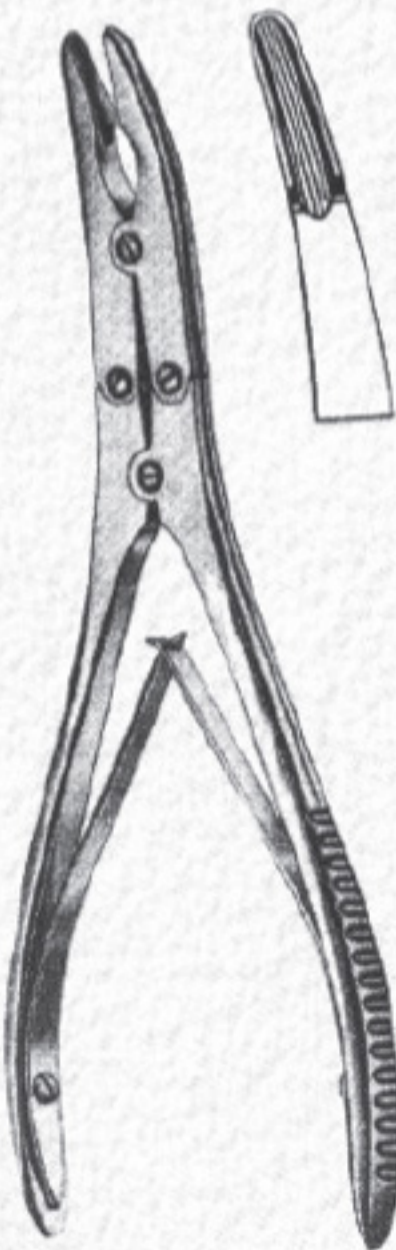

786-234
Beyer
18 cm
Multiple Action

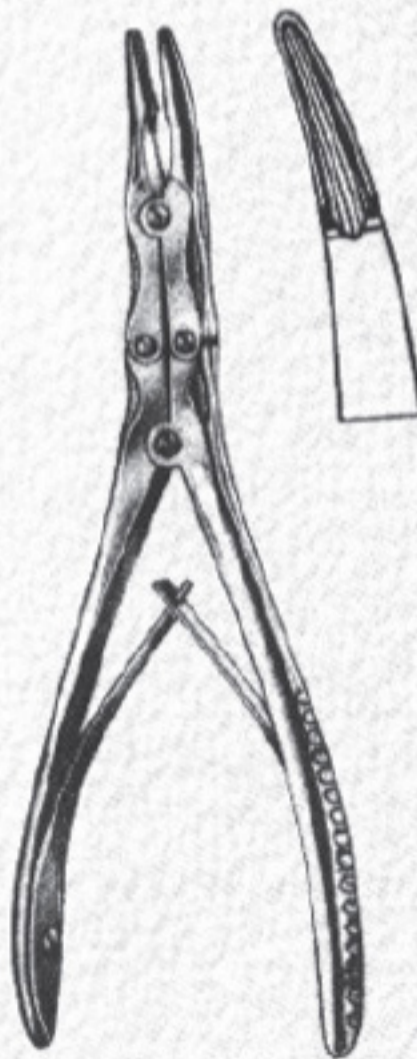

786-235
Ruskin-mini
15,5 cm

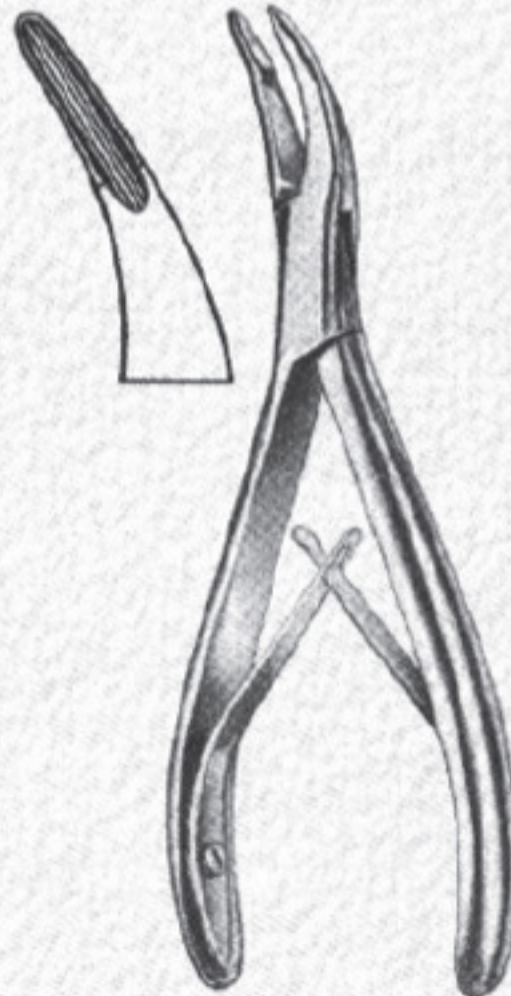

786-236
Luer
15 cm



786-237
Friedman
14 cm



786-238
Mini-Friedman
12 cm



Root Elevators

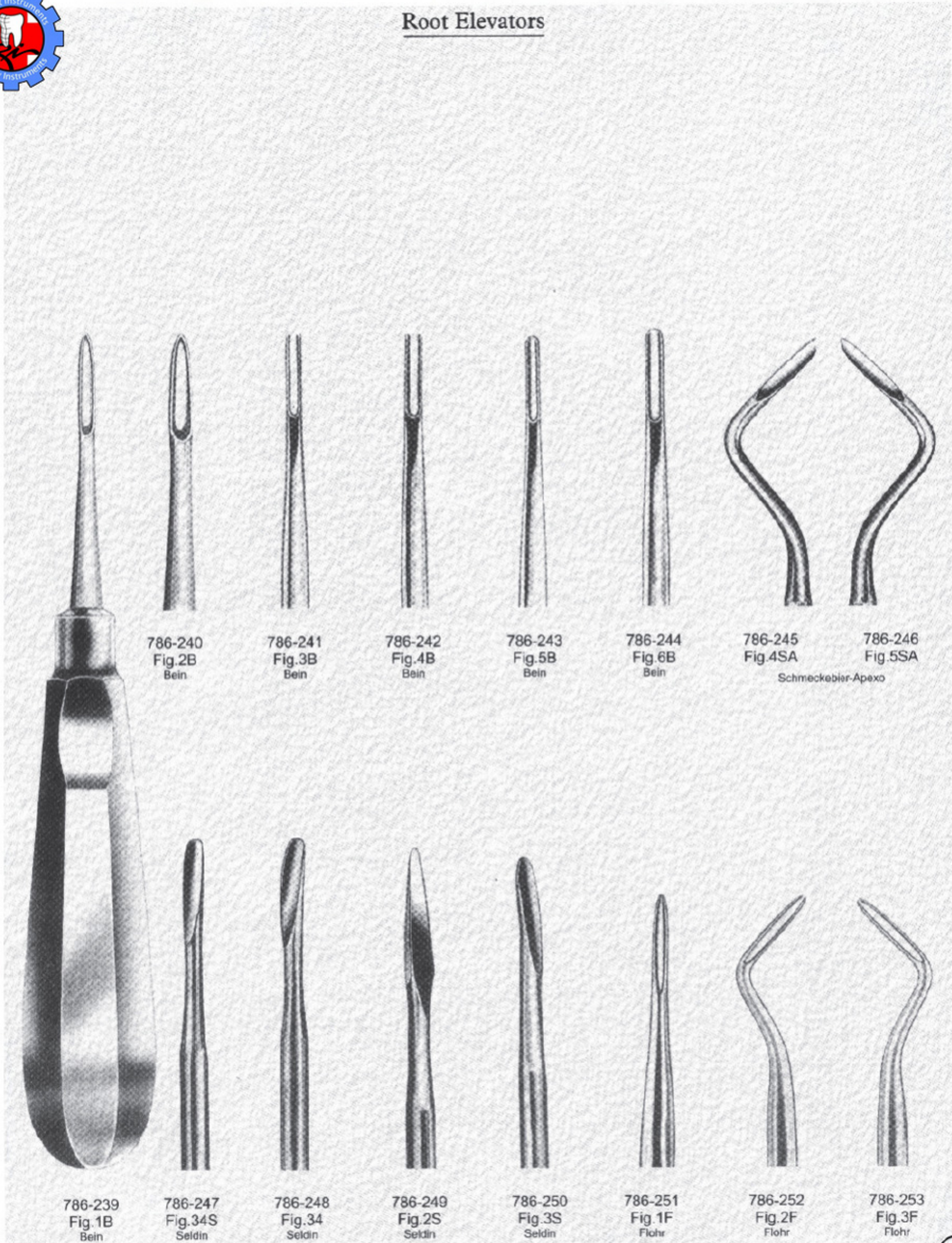



Root Elevators

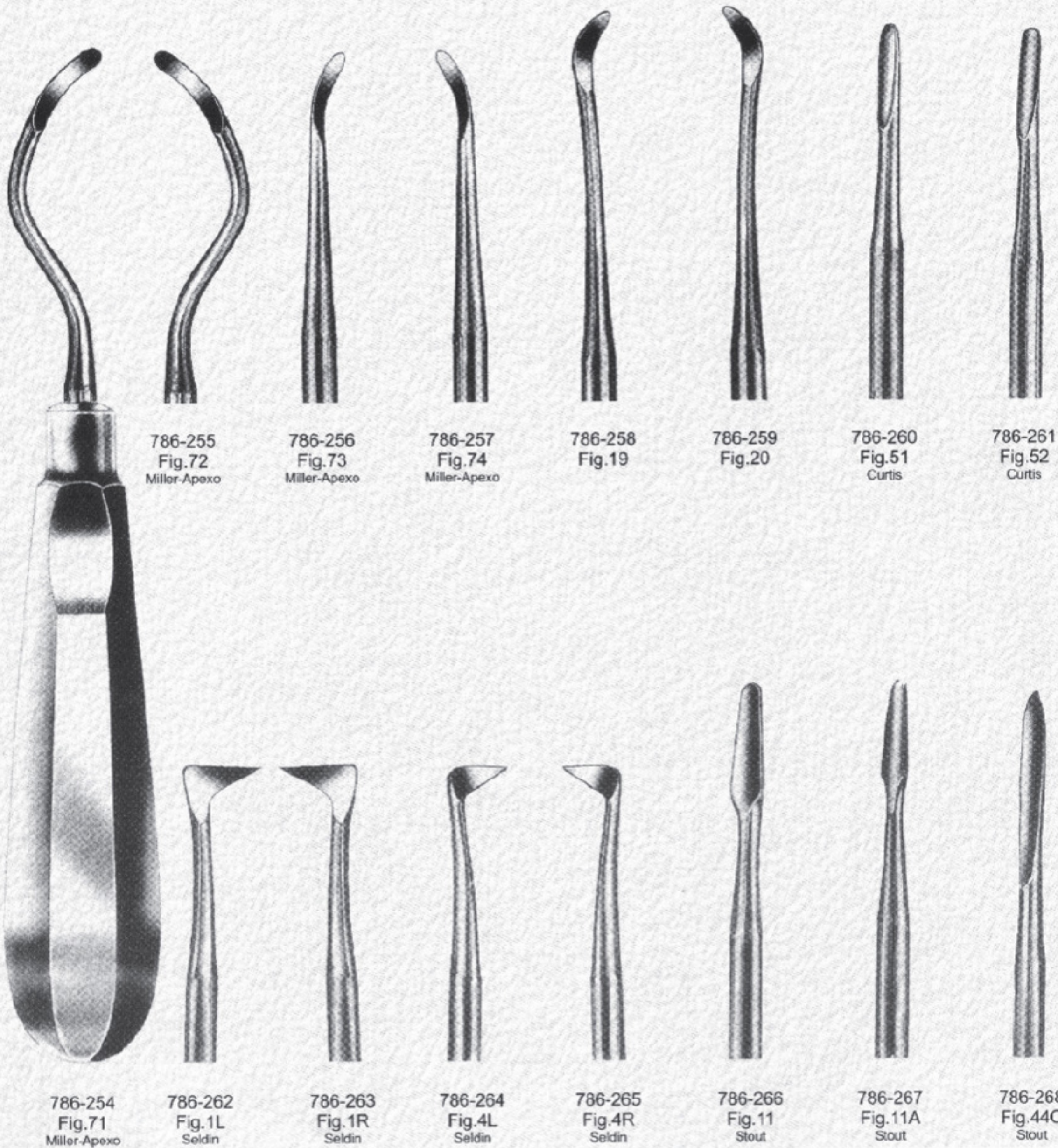



Root Elevators

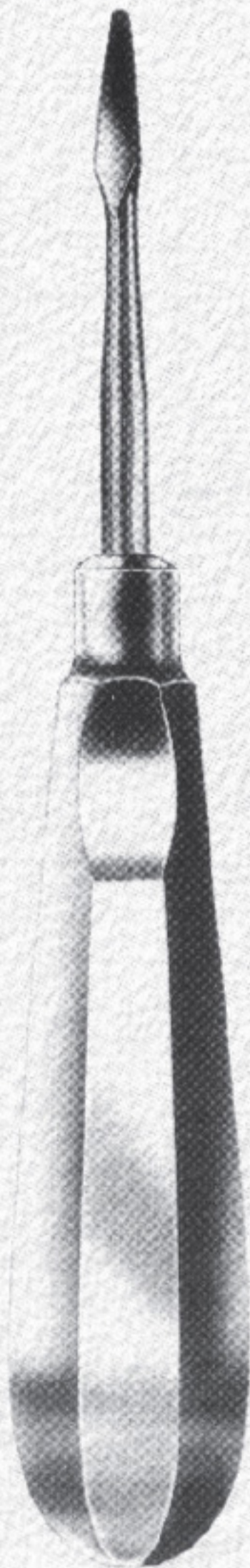

786-269
Fig.A
Cogswell



786-270
Fig.B
Cogswell



786-271
Fig.301
Apexo



786-272
Fig.302
Apexo



786-273
Fig.303
Apexo



786-274
Fig.301W
Seldin



786-275
Fig.304W
Seldin



786-276
Fig.1H
Heidbrink



786-277
Fig.2H
Heidbrink



786-278
Fig.40H
Heidbrink



786-279
Fig.41H
Heidbrink



786-280
Fig.46



786-281
Fig.46R



Root Elevators

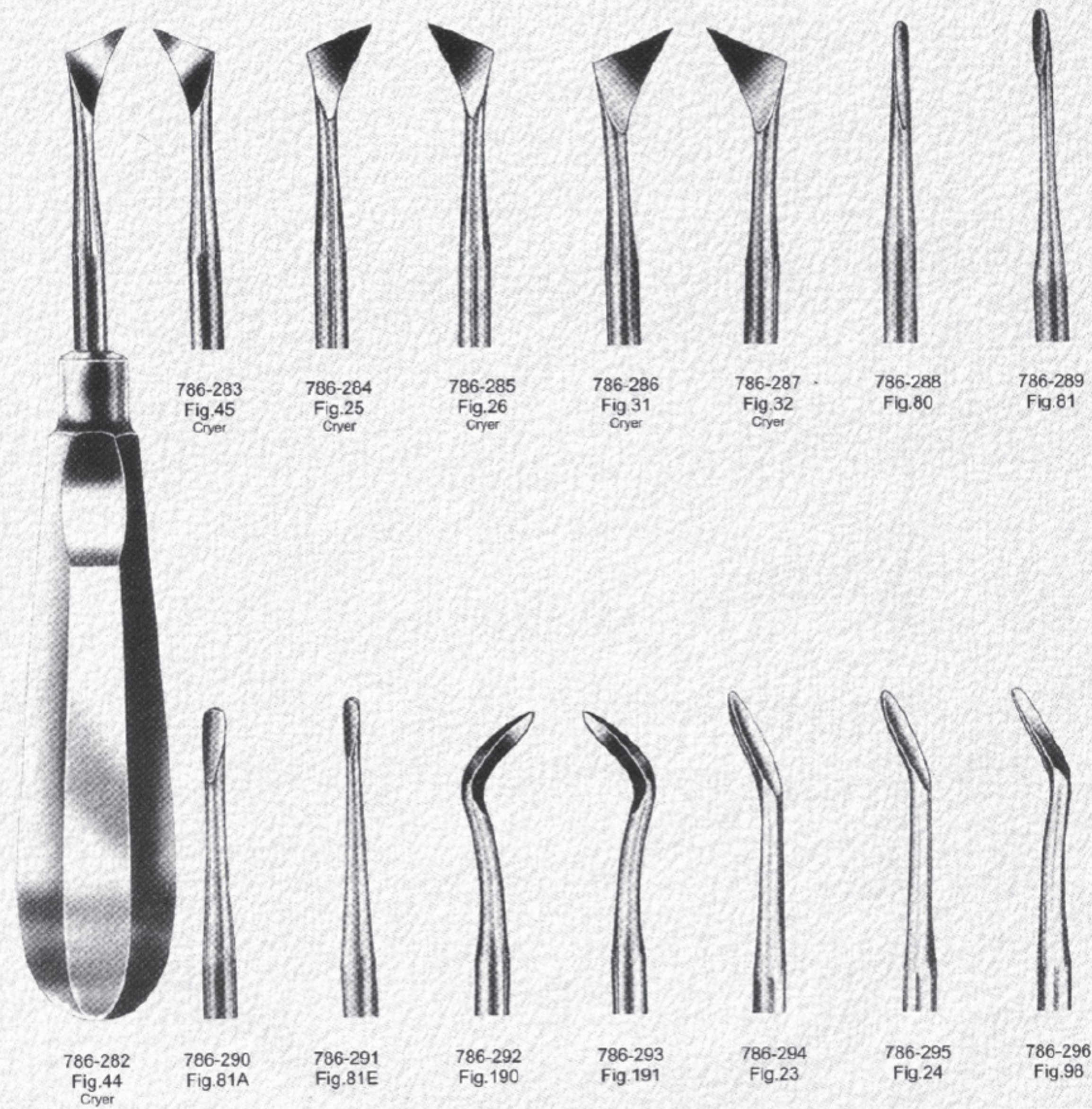



Root Elevators

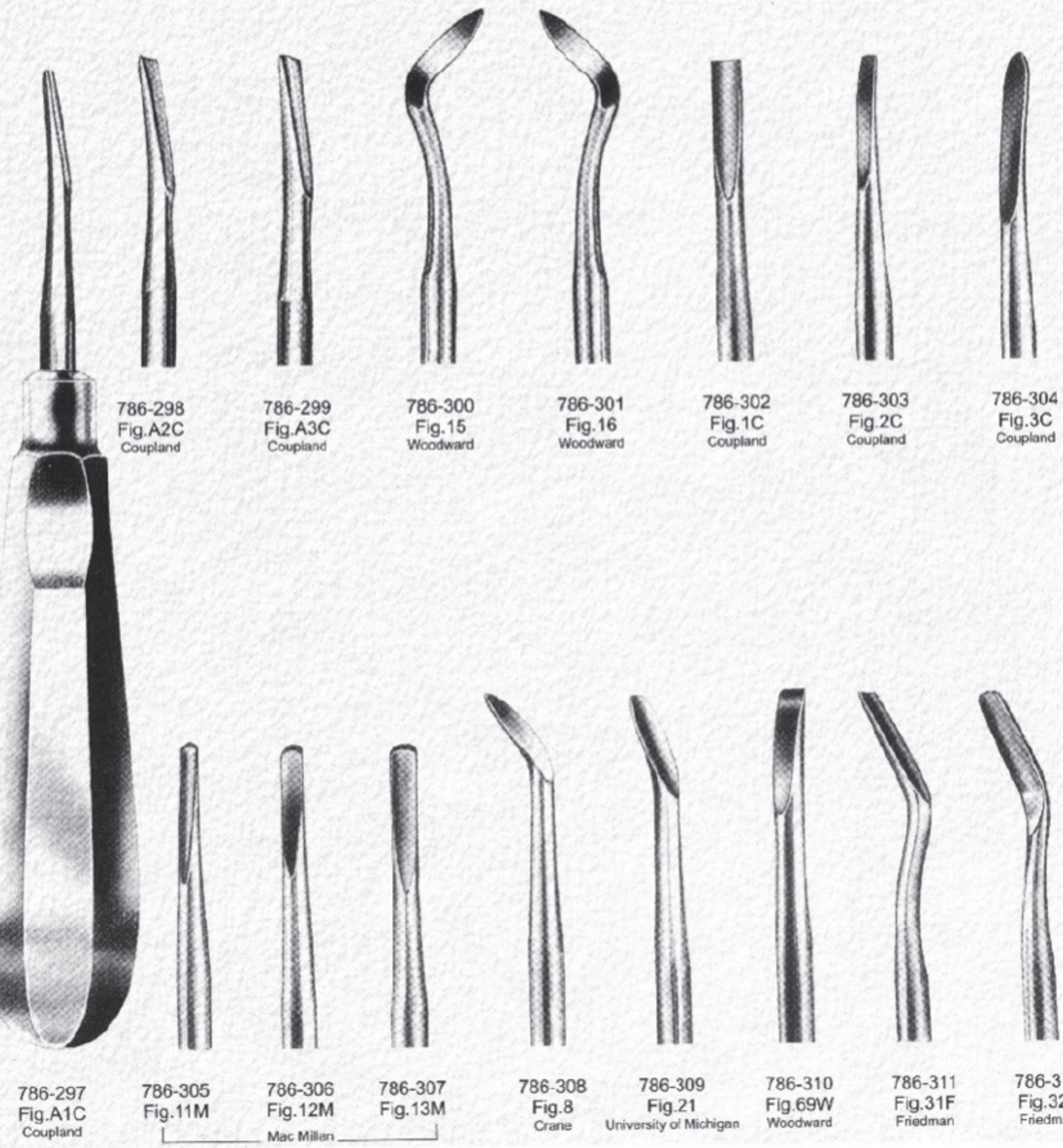

786-298
Fig.A2C
Coupland

786-299
Fig.A3C
Coupland

786-300
Fig.15
Woodward

786-301
Fig.16
Woodward

786-302
Fig.1C
Coupland

786-303
Fig.2C
Coupland

786-304
Fig.3C
Coupland

786-297
Fig.A1C
Coupland

786-305
Fig.11M
Mac Millan

786-306
Fig.12M
Mac Millan

786-307
Fig.13M
Mac Millan

786-308
Fig.8
Crane

786-309
Fig.21
University of Michigan

786-310
Fig.69W
Woodward

786-311
Fig.31F
Friedman

786-312
Fig.32F
Friedman



Root Elevators



786-313
Fig.1
Bein



786-314
Fig.2
Bein



786-315
Fig.3
Bein



786-316
Fig.4
Bein



786-317
Fig.5
Bein



786-318
Fig.6
Bein



786-319
Fig.1

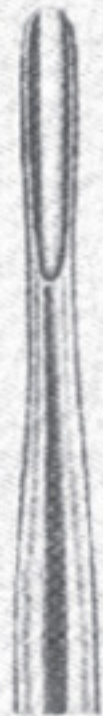

786-320
Fig.2



786-321
Fig.2
Flohr



786-322
Fig.3
Flohr



786-323
Fig.7
Cryer



786-324
Fig.8
Cryer



Root Elevators



786-325
Fig.1
Heidbrink



786-326
Walter F. Barry



786-331
Fig.2
Heidbrink



786-332
Fig.3
Heidbrink

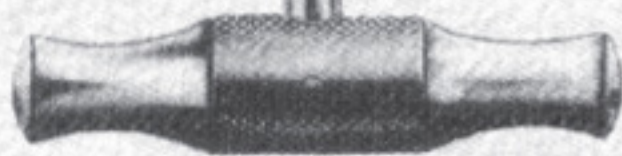

786-333
Winter



786-334
Fig.11LW



786-335
Fig.11RW



786-336
Fig.12LW



786-337
Fig.12RW



786-327
Fig.320



786-328
Fig.321



786-329
Fig.322



786-330
Fig.323

Walter F. Barry

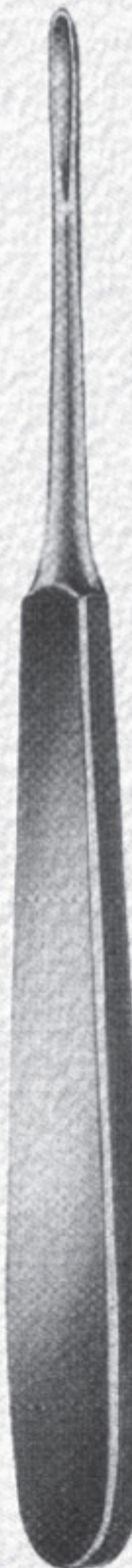

786-339
Fig.2
Warwick-James

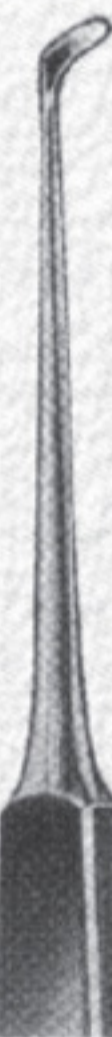

786-340
Fig.3
Warwick-James

786-338
Fig.1
Warwick-James



Pliers For Orthodontics & Prosthetics

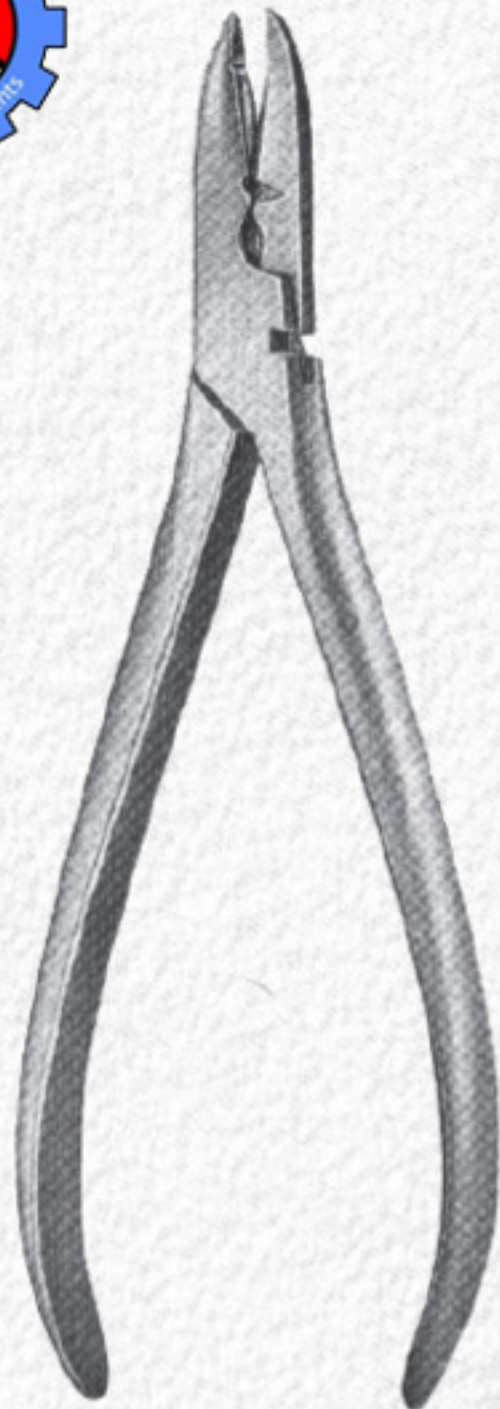

786-341
Waldsachs
15 cm



786-342
Universal
16 cm

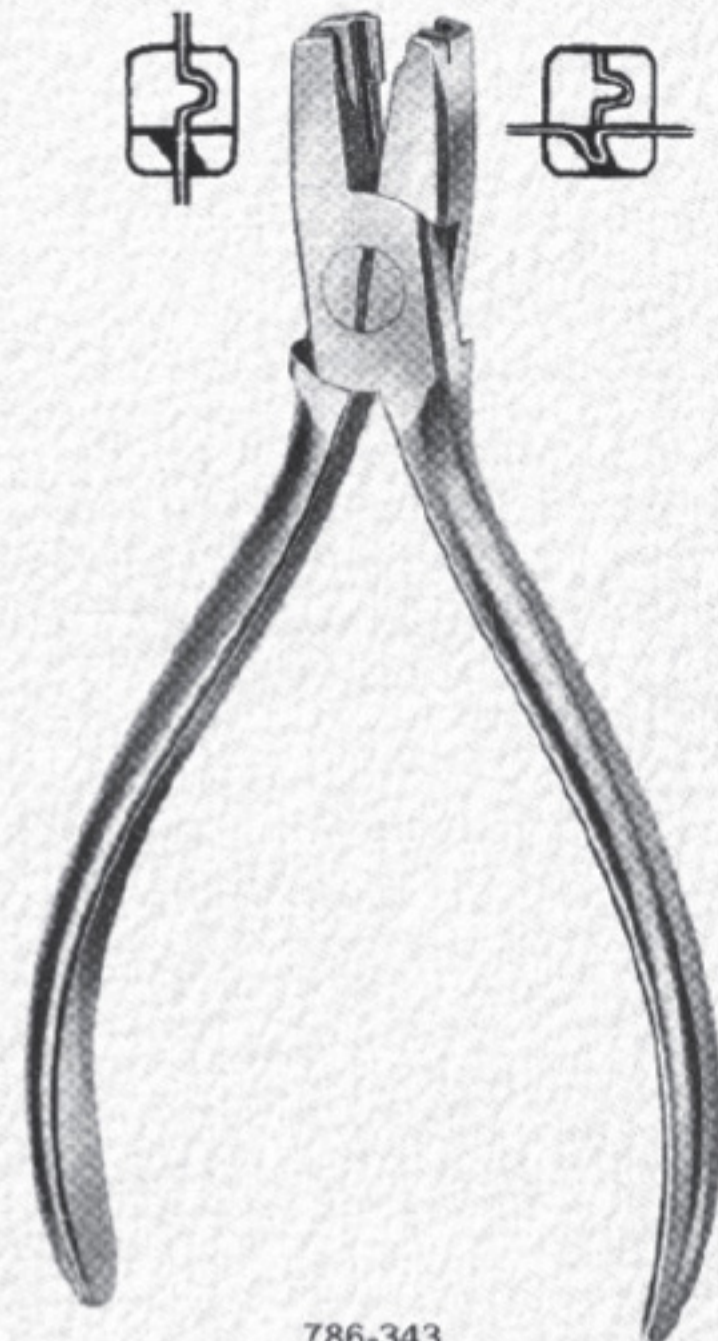

786-343
Nance
13.5 cm

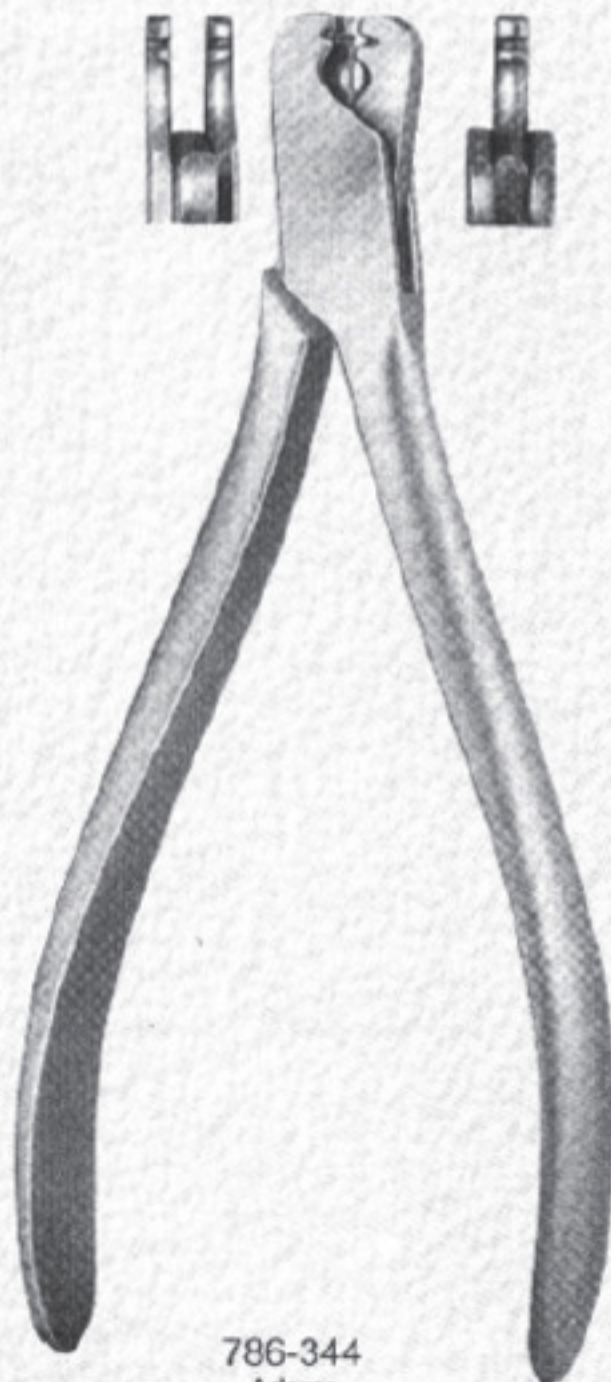

786-344
Aderer
14.5 cm



786-345
Modell marburg
Serrated Jaws
14 cm



786-346
Modell marburg
Smooth jaws
14 cm



786-347
Modell marburg
Carbid Inserts jaws
14 cm

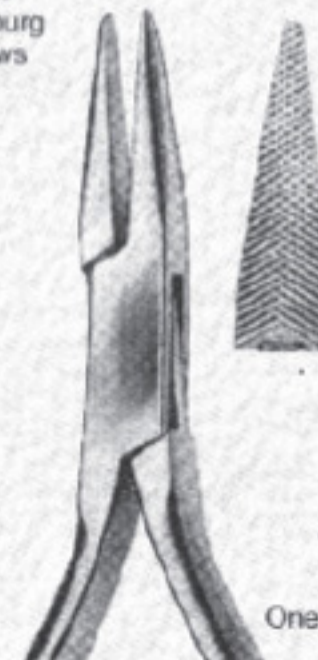

786-348
Goslee
One Serrated Jaws
14 cm



Pliers For Orthodontics & Prosthetics

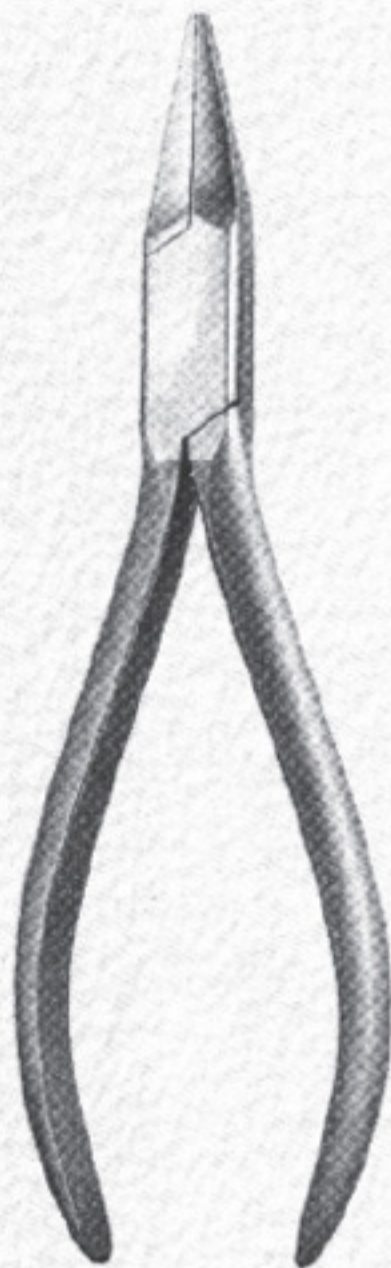

786-349
14 cm



786-350
14 cm



786-351
14 cm



786-352
14,5 cm



786-353
14,5 cm



786-354
14 cm



786-355
14 cm



786-356
14 cm



786-357
Serrated Jaws
12 cm



786-358
How
14,5 cm



786-359
How-angled
14,5 cm



786-360
Arrow clasp forming
12 cm

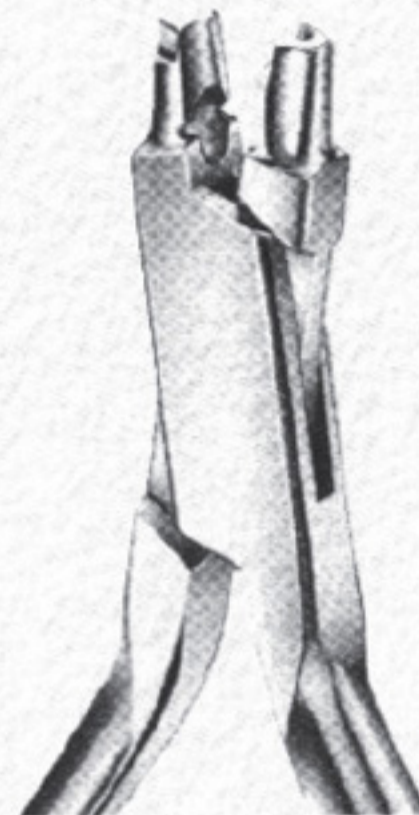

786-361
Arrow clasp forming
12 cm



786-362
Arrow clasp bending
12 cm



Pliers For Orthodontics & Prosthetics

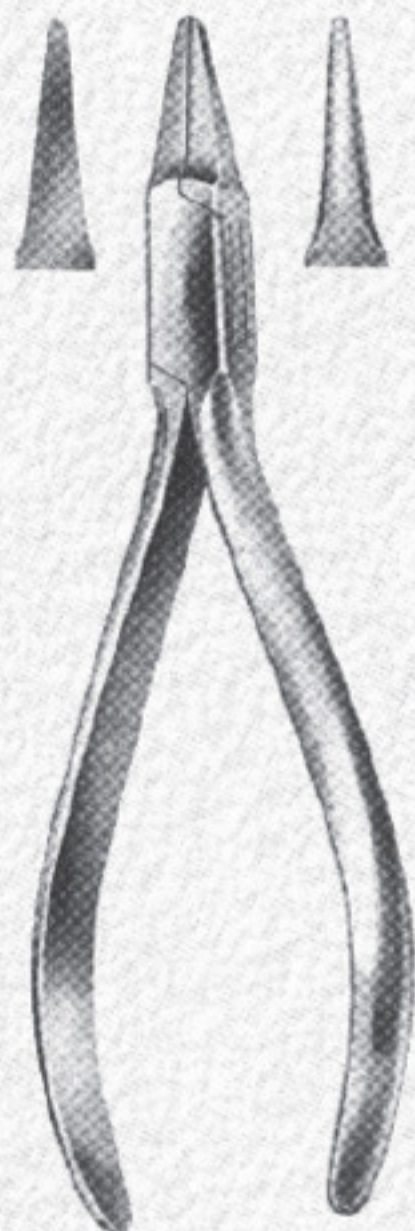

786-363
Peeso
13,5 cm

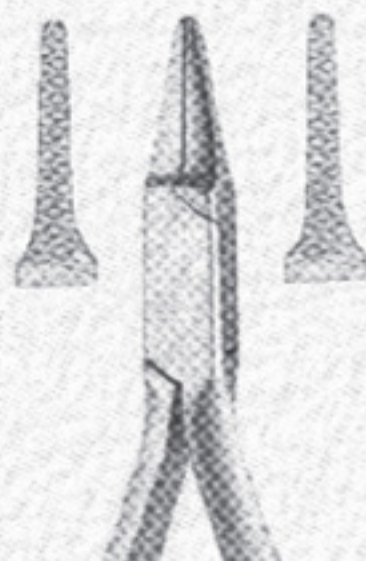

786-364
Peeso
13,5 cm

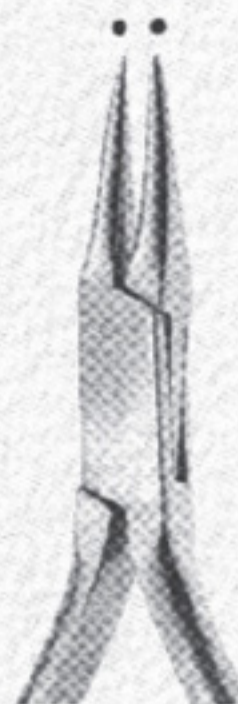

786-365
14 cm

Round nose pliers



786-366
Langenbeck
14 cm

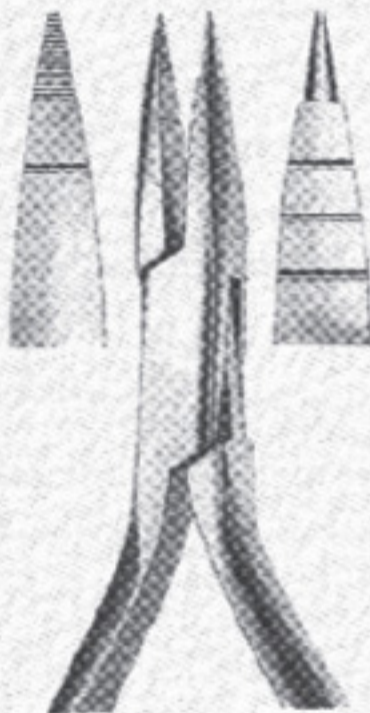

786-367
14 cm

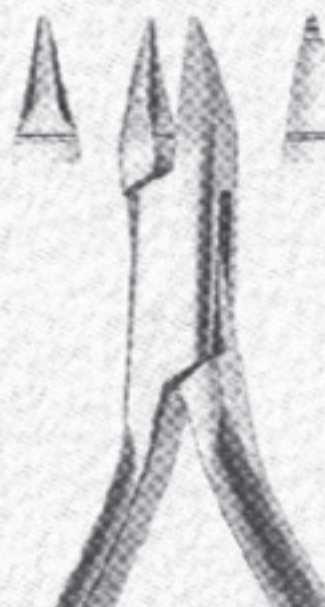

786-368
13 cm

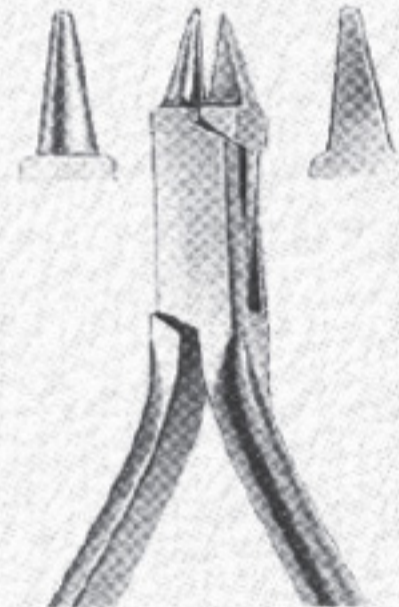

786-369
Angle
12,5 cm

For wire up to

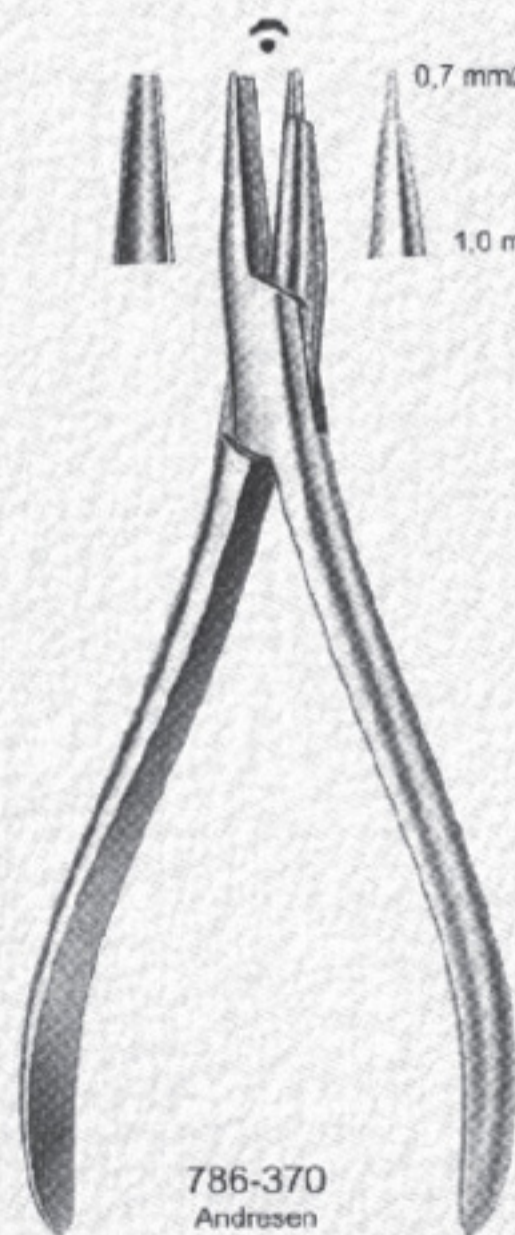
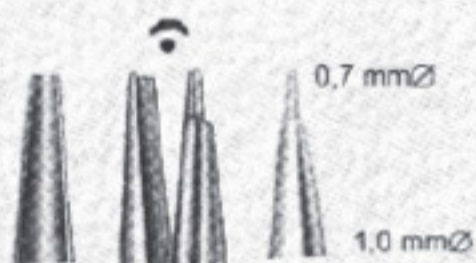

786-370
Andresen
13 cm

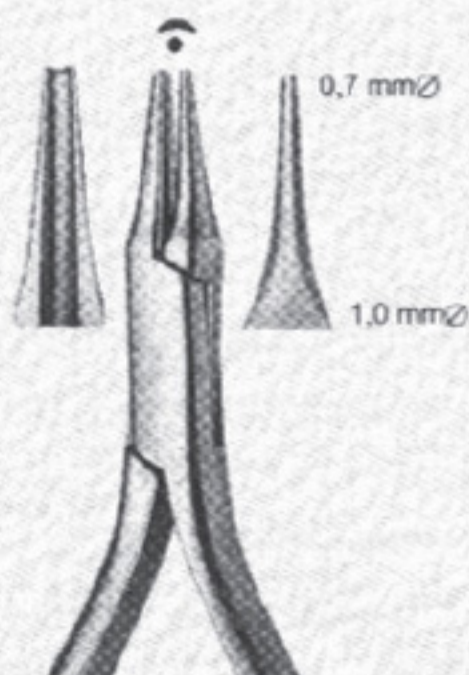

786-371
13,5 cm

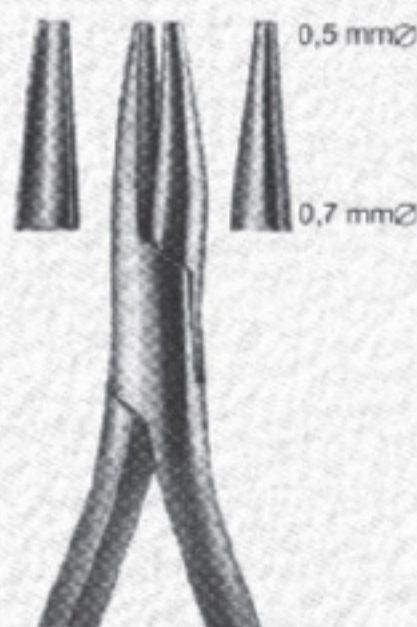

786-372
Schwarz
13,5 cm

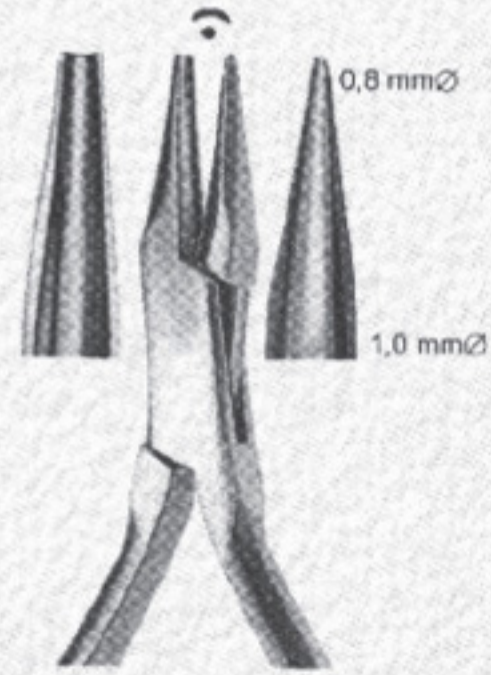

786-373
Fischer
13 cm



Pliers For Orthodontics & Prosthetics

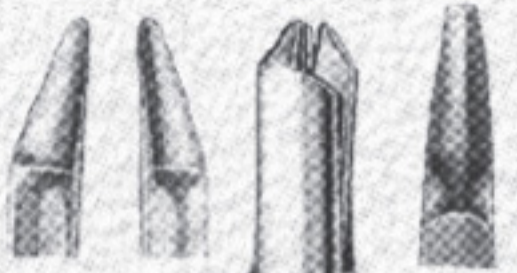

786-374
Aderer
12 cm



786-375
Aderer-Heavy
12 cm

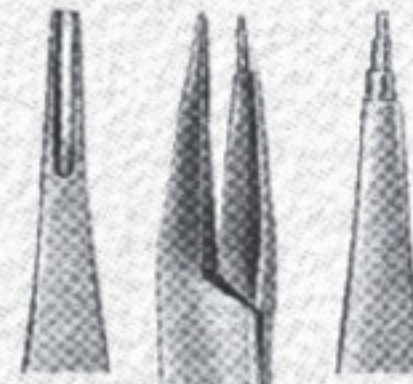

786-376
Tweed
14.5 cm

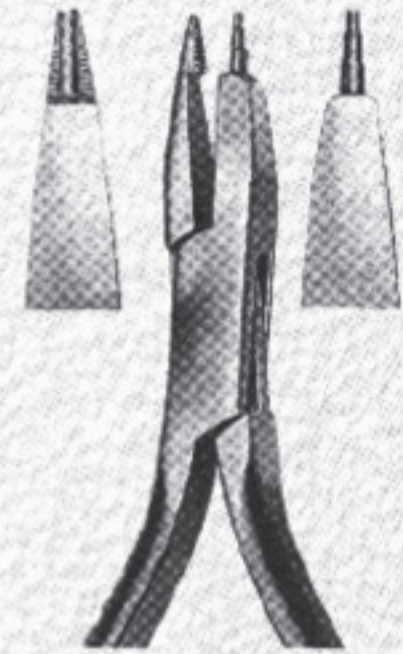

786-377
O'Brien
13.5 cm

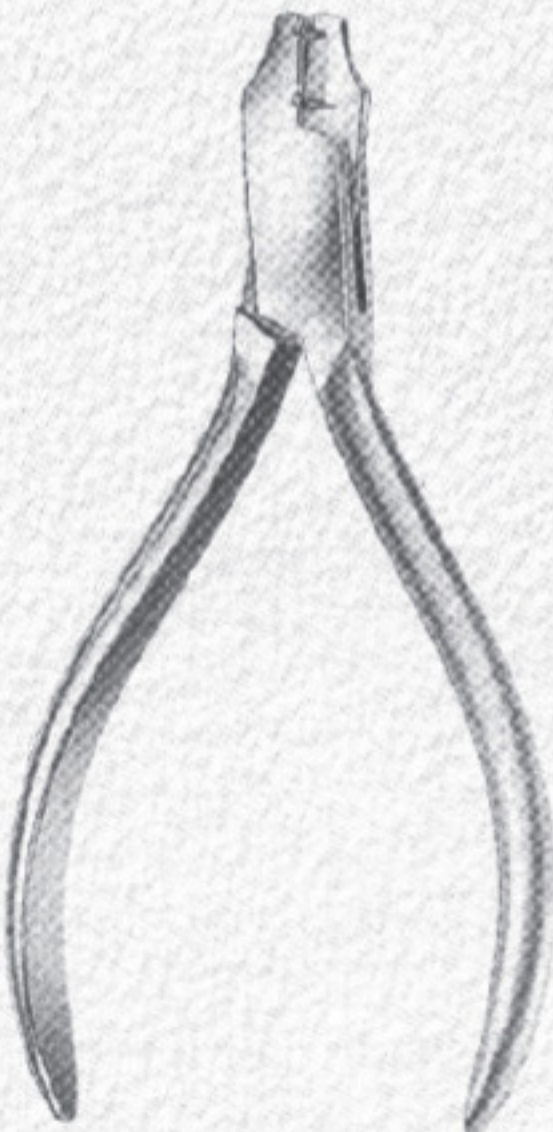

786-378
Wire bending pliers
12.5 cm

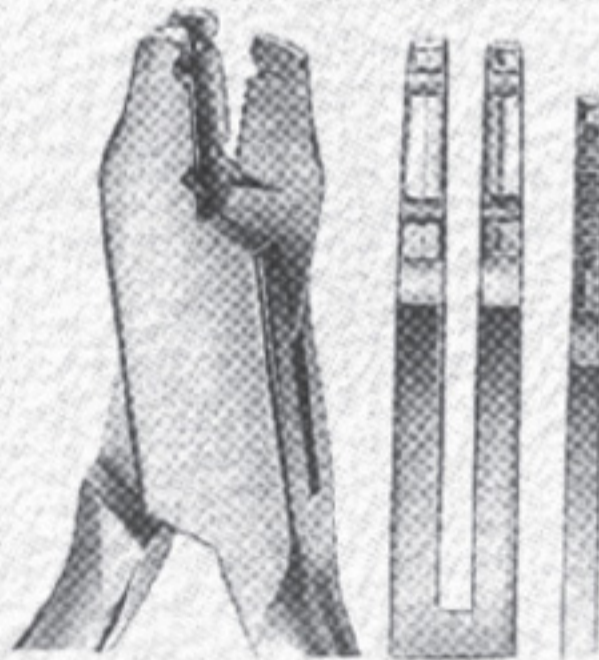

786-379
Adams
12.5 cm

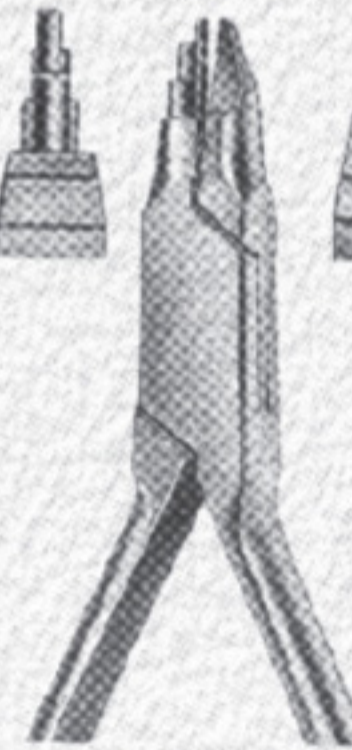
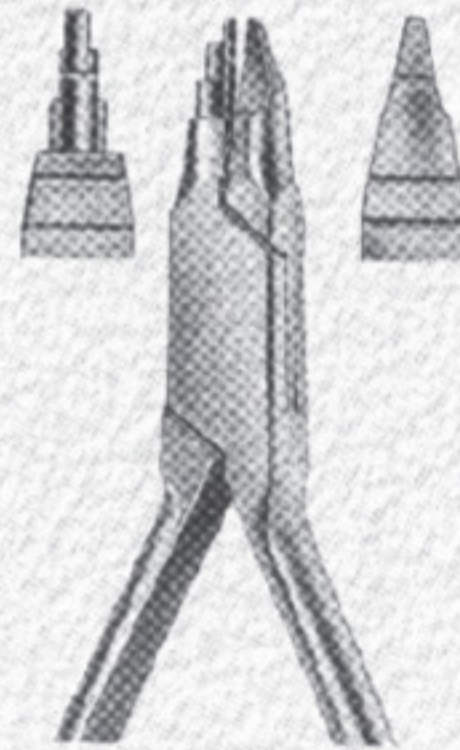

786-381
Young
14 cm



786-380
Frevert
12.5 cm

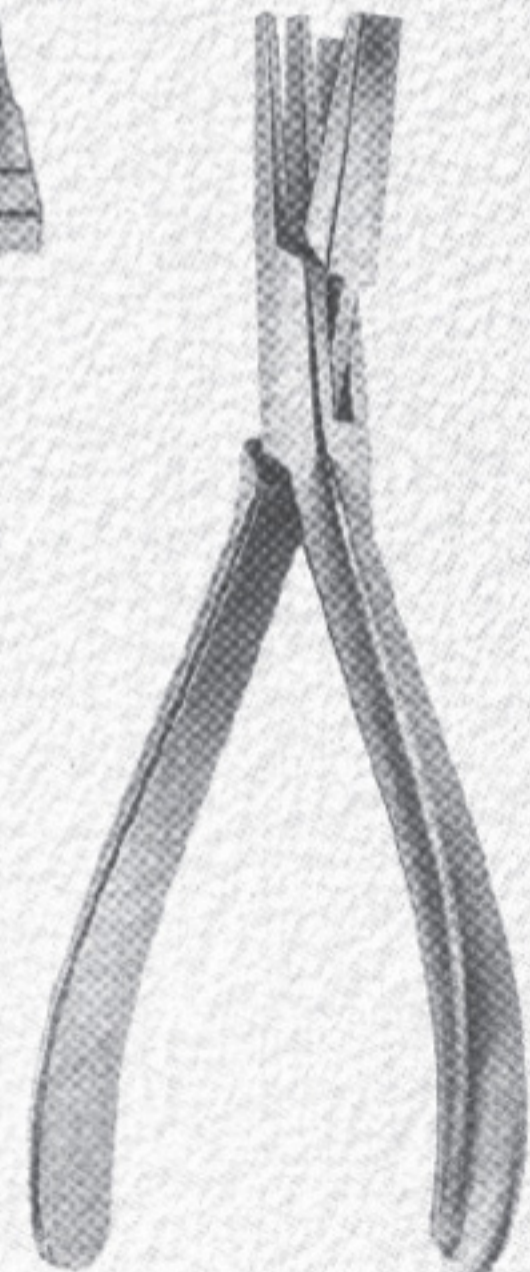

786-382
Clasp forming
14 cm



Ligature Instruments

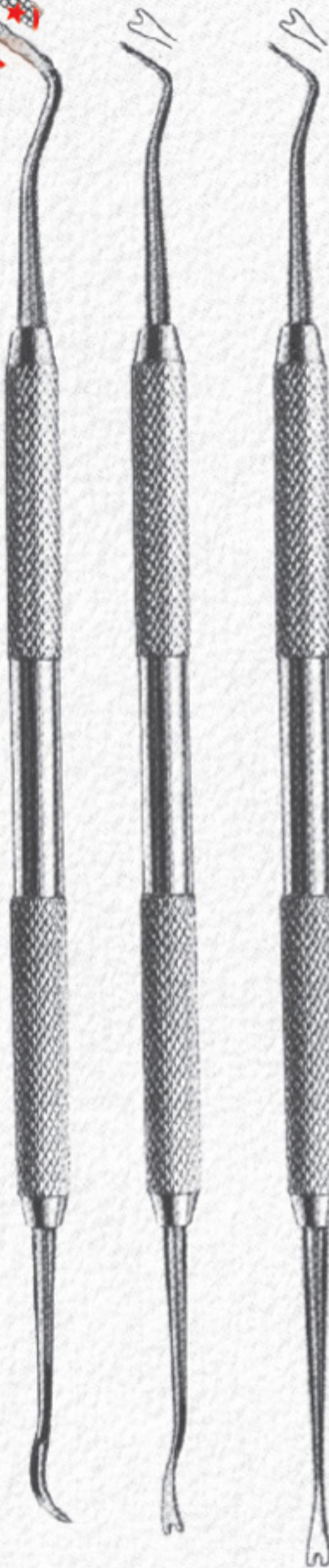

786-383
Band seating &
removing instruments

786-384

786-385

Orthodontics Instruments



786-386
Elastic instruments

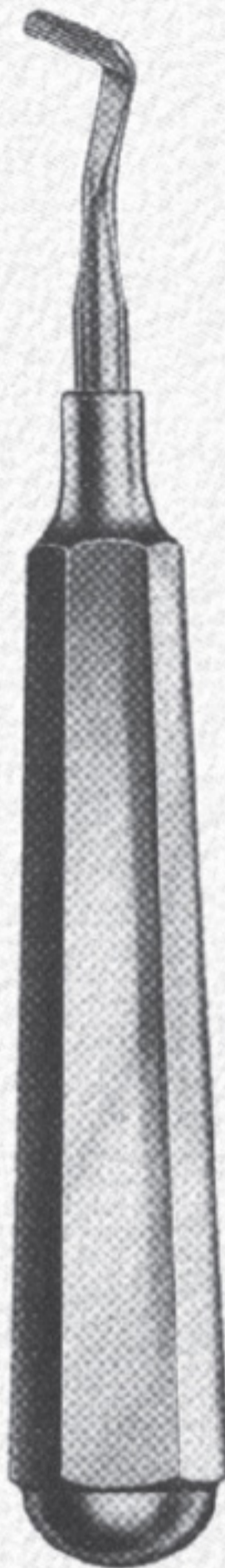

786-387
Mershon Band Pusher
14 cm



786-388
Band Setter with
tin insert
15 cm



786-389
13,5 cm

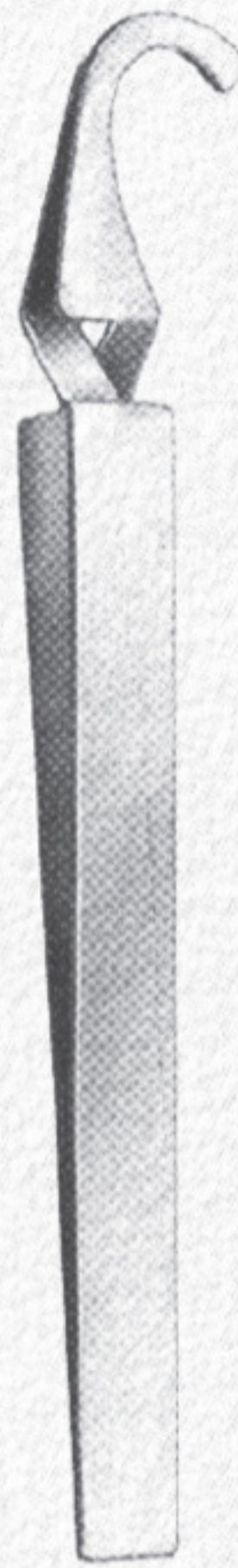

786-390
14 cm

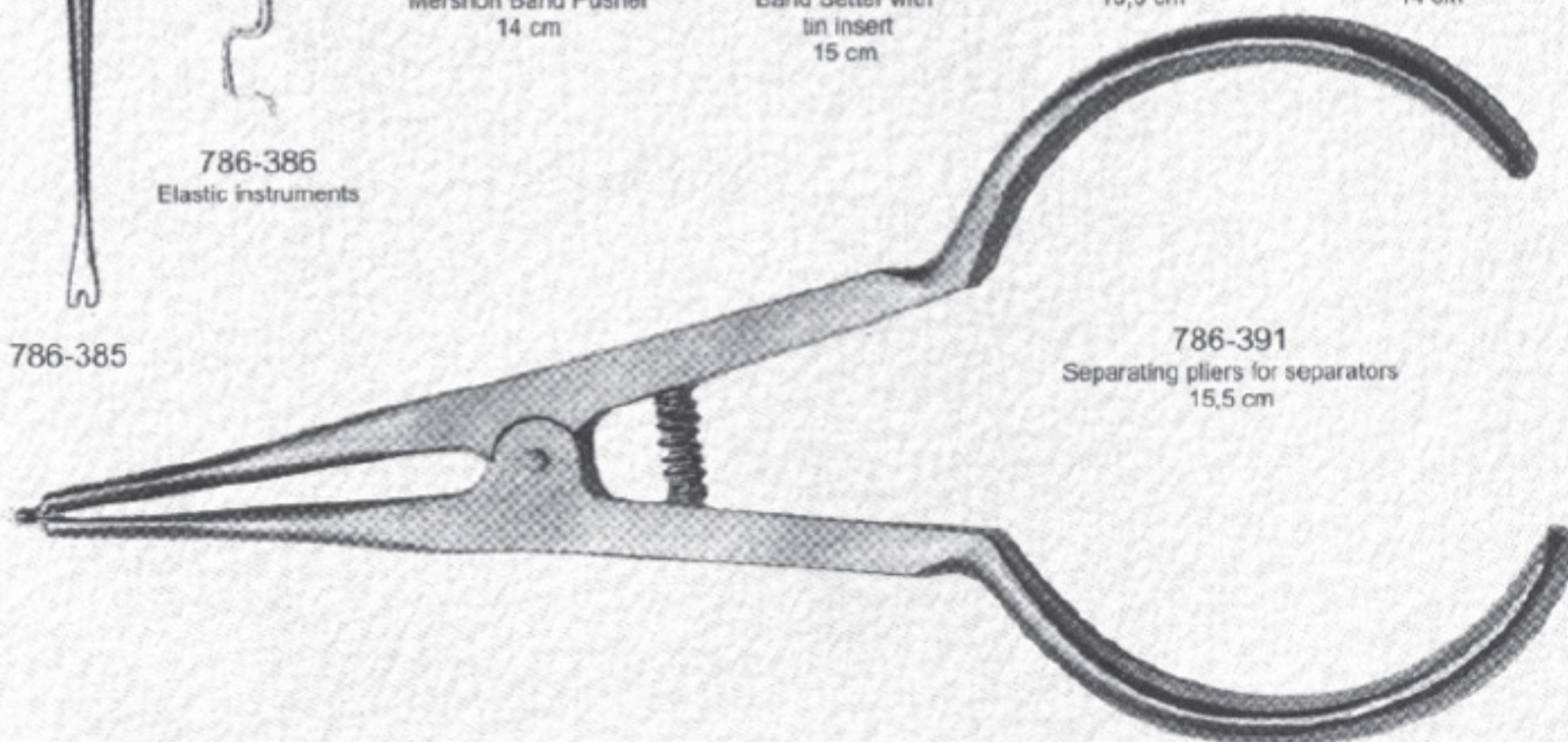

786-391
Separating pliers for separators
15,5 cm



Orthodontics Instruments

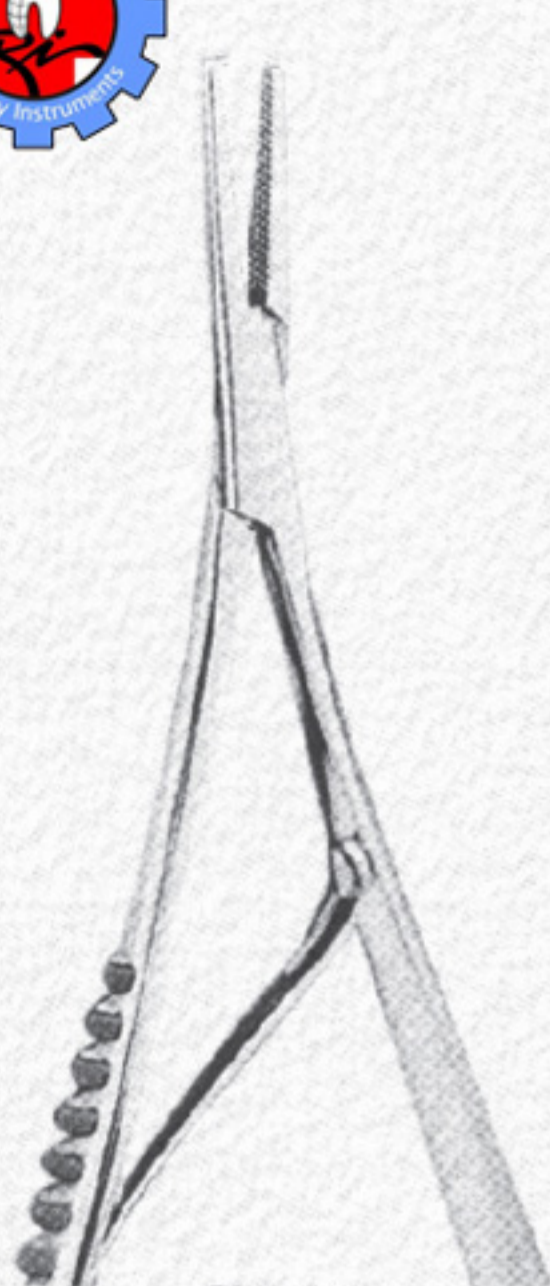

786-392
Mathieu pliers
14 cm

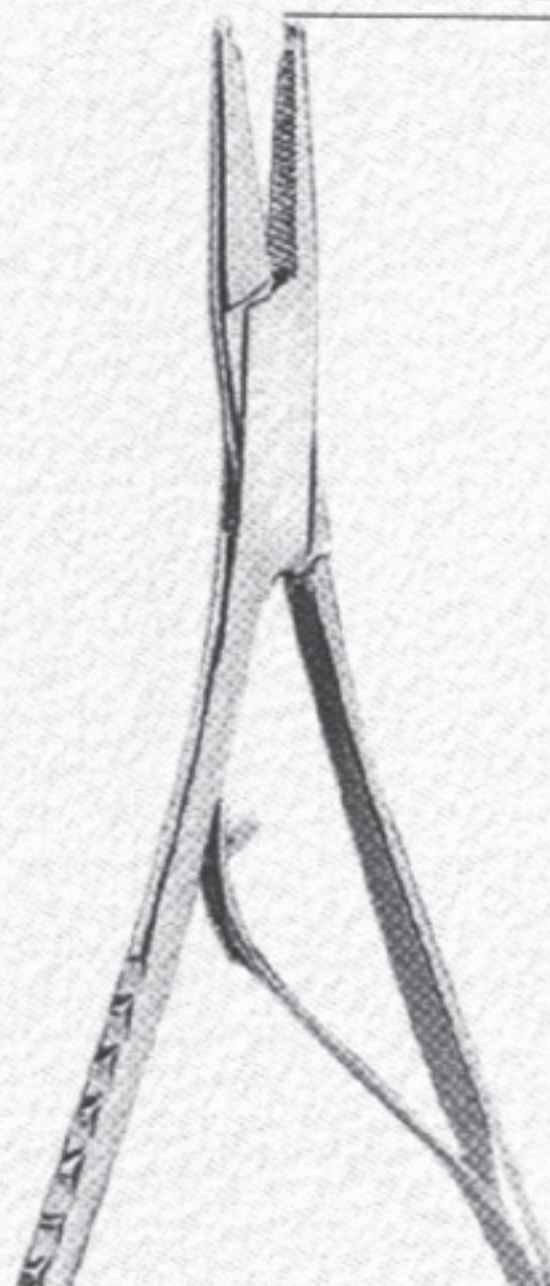

786-393
Elastic ligature placing pliers
14 cm

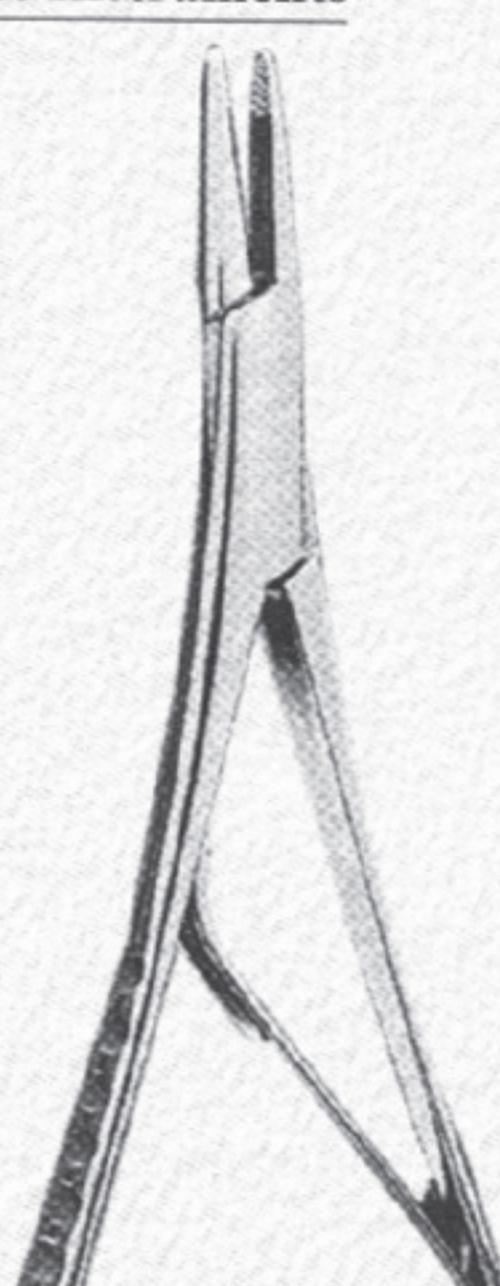

786-394
Mathieu ligating pliers
14 cm



786-395
Mathieu plier
with finger ring
14 cm

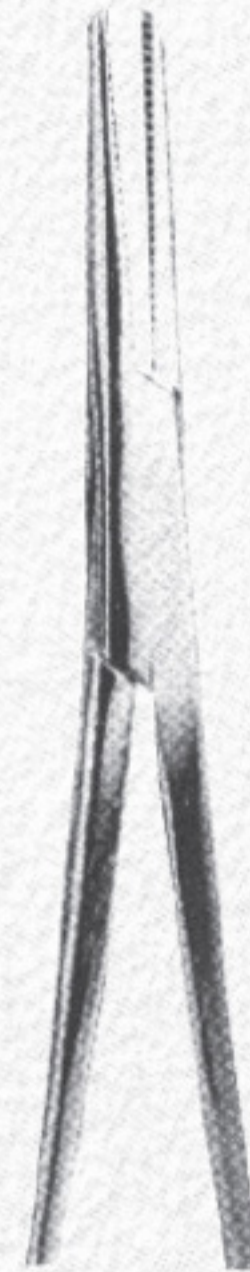

786-396
Mosquito plier



786-398
Bracket placing tweezers



786-399
Bracket placing tweezers

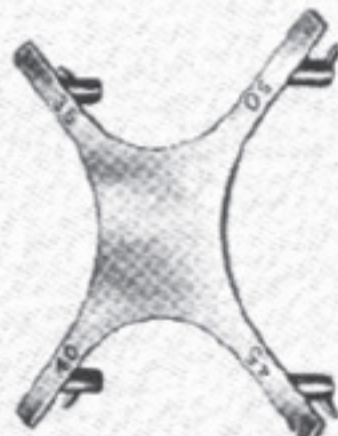

786-397
Bracket positioning gauge



786-400
Ligature tying plier



786-401
Bracket holding tweezers



786-402
Band seating instrument
Nylon

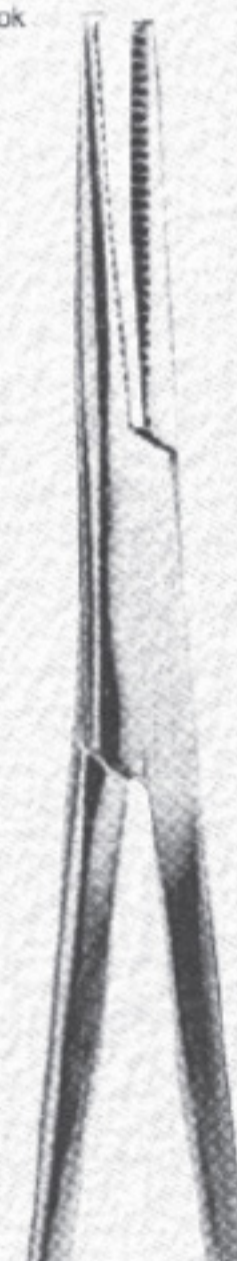

786-403
Mosquito forceps

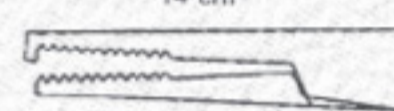

Hook





Gum Scissors

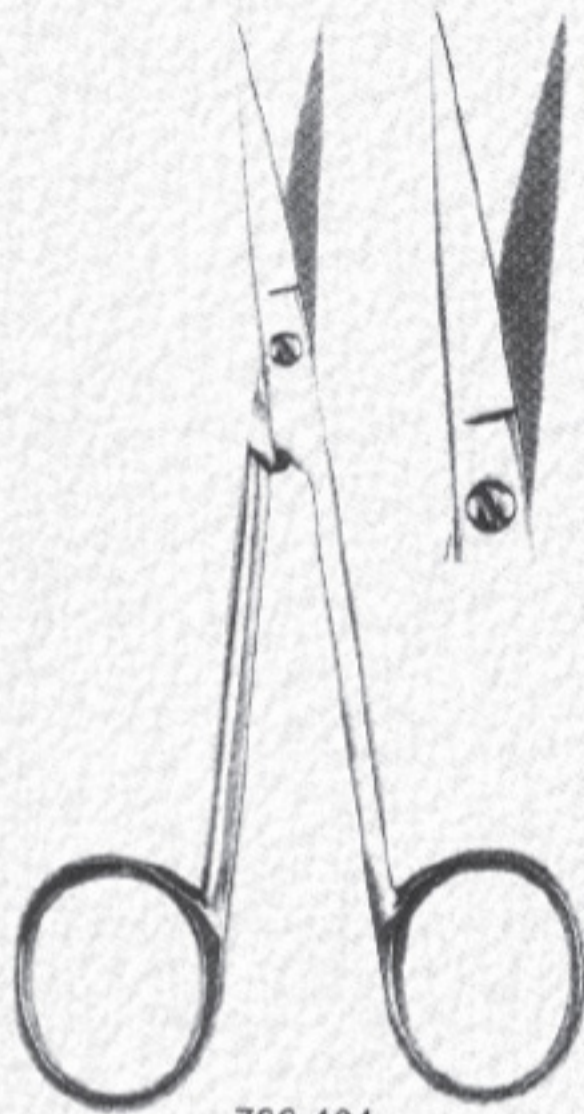

786-404
Fig.1
12cm
Straight

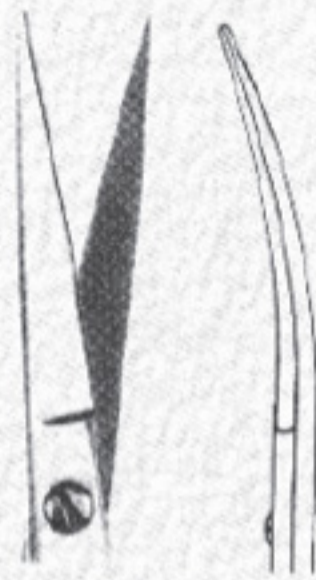

786-405
Fig.2
12cm
Curved

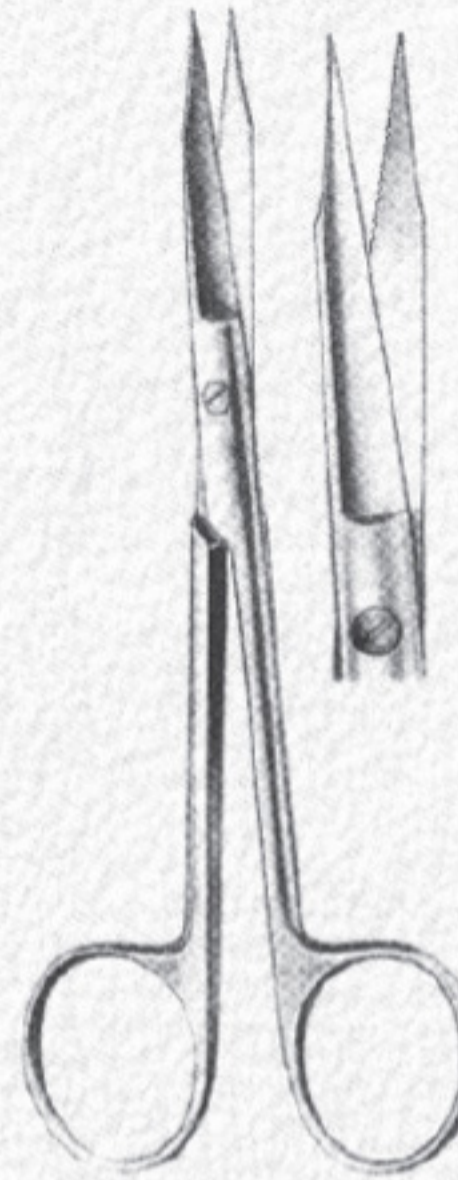

786-406
Fig.1
13cm
Goldman-Fox
Saw edge
Straight

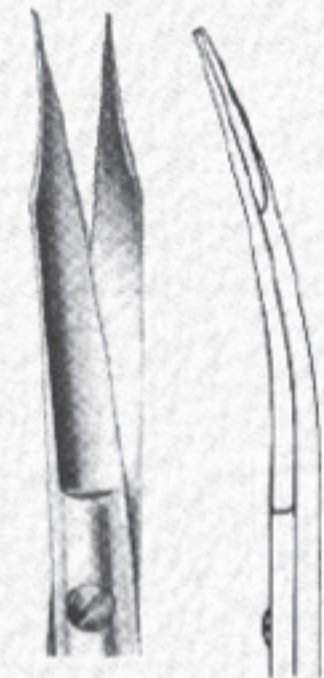

786-407
Fig.2
13cm
Goldman-Fox
Saw edge
Curved

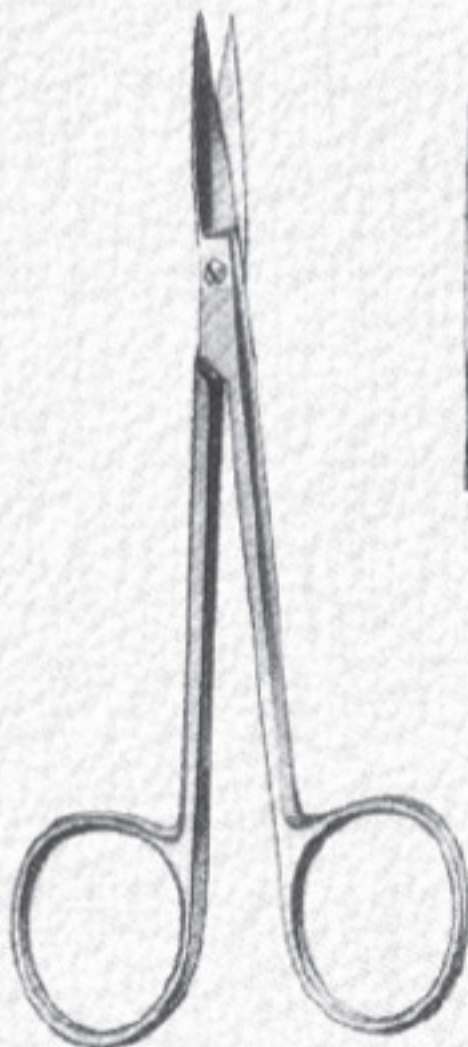

786-408
Fig.1
11.5cm
Iris
Straight



786-409
Fig.2
11.5cm
Iris
Curved



786-410
Fig.3
11.5cm
Iris



786-411
Fig.1
11.5cm
Angular, Saw edge

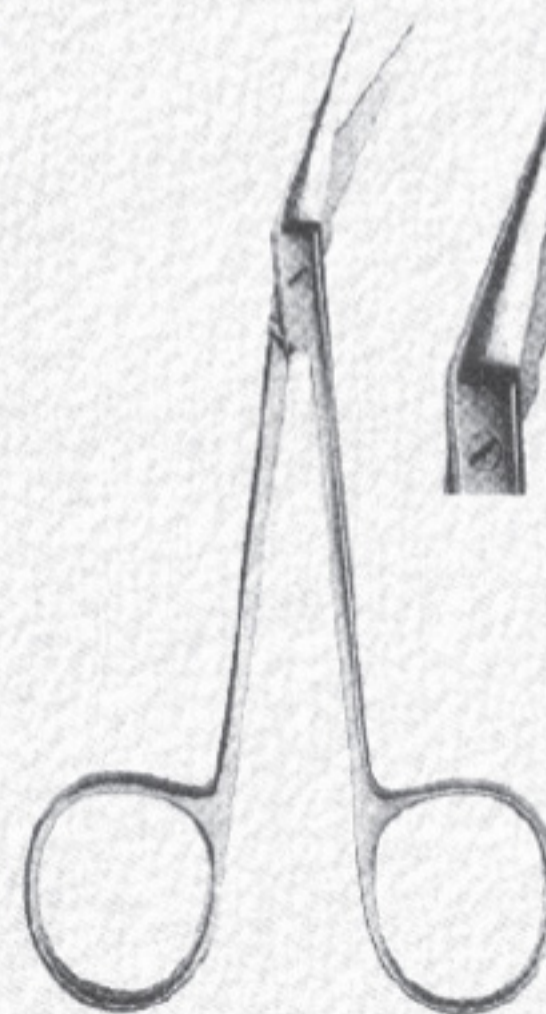

786-412
Fig.2
11.5cm
Angular





Gum Scissors

Curved, saw edge



786-413
Fig.1
La Grange
10,5 cm

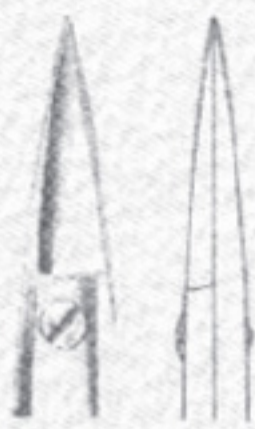

Straight

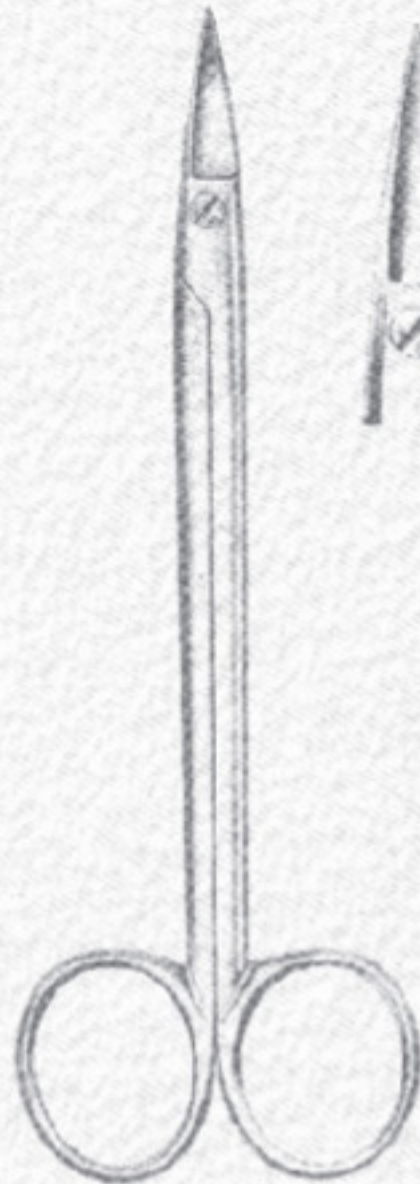

786-414
Fig.1
Quinby
12,5 cm



Curved

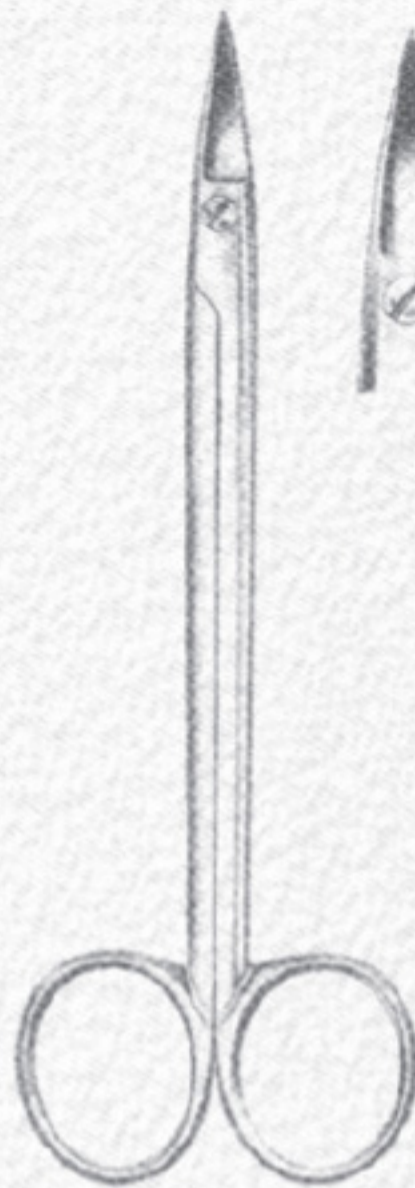

786-415
Fig.2
Quinby
12,5 cm

Curved, saw edge



786-416
Fig.3
Goldman-Fox (Special)
13 cm

Straight

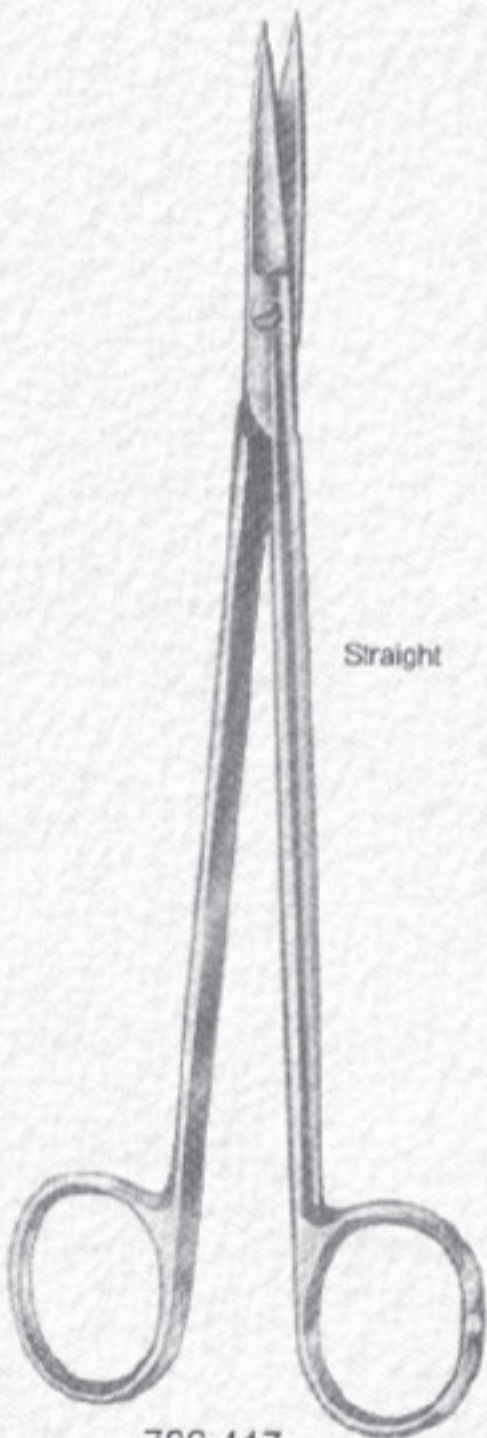

786-417
Fig.1
Kelly
16 cm

Curved

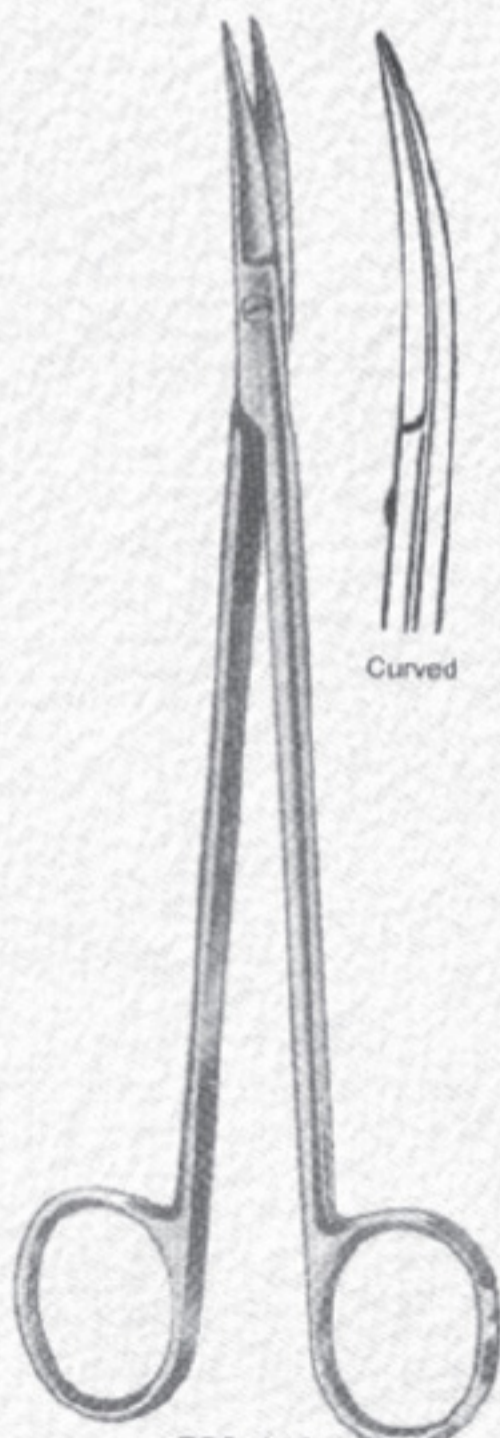

786-418
Fig.2
Kelly
16 cm

saw edge

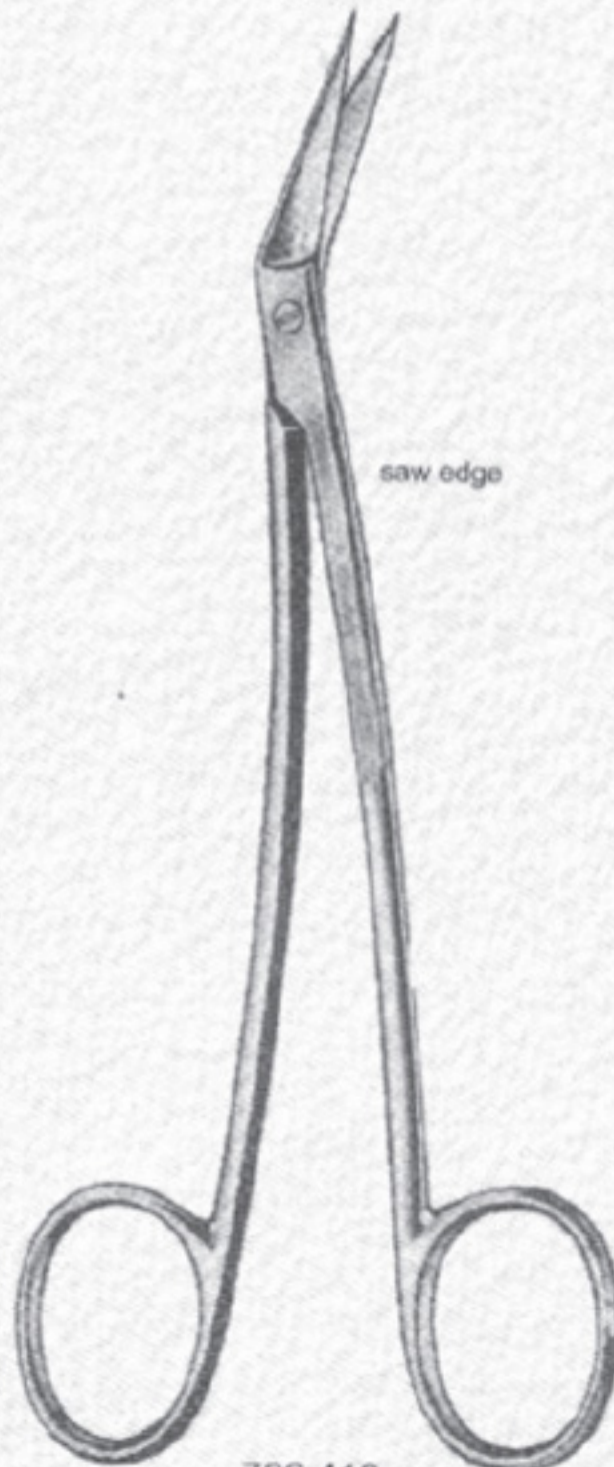

786-419
Fig.1
Locklin
16,5 cm

saw edge

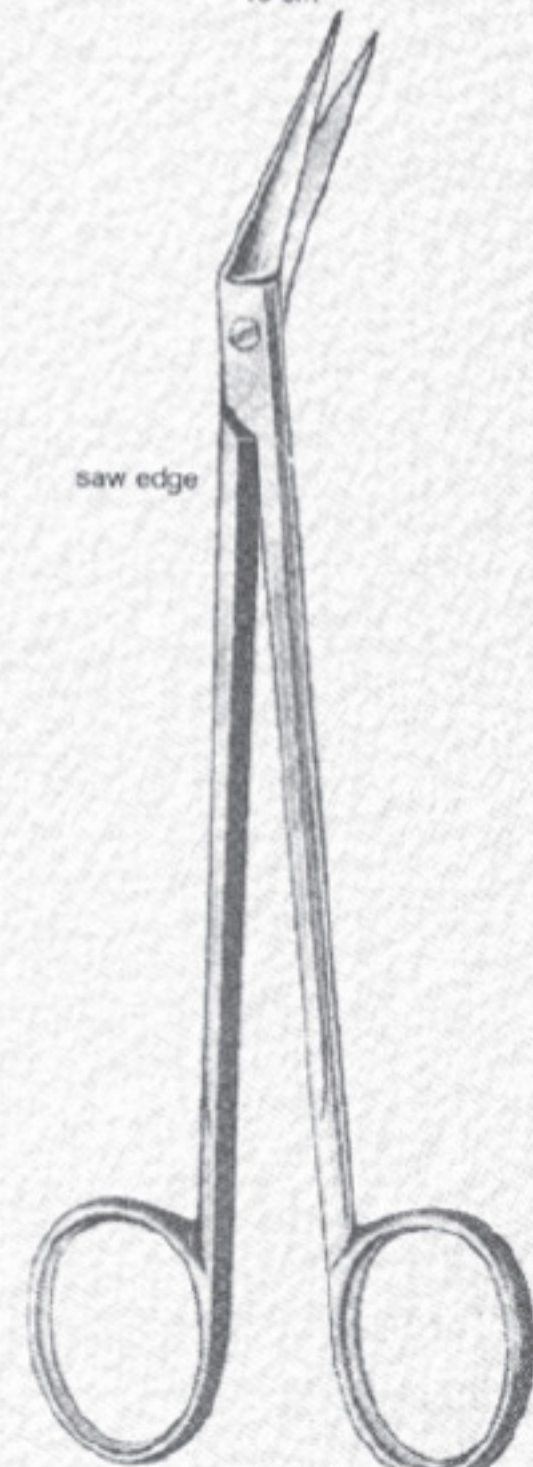

786-420
Fig.2
Locklin
16,5 cm



Surgical Scissors

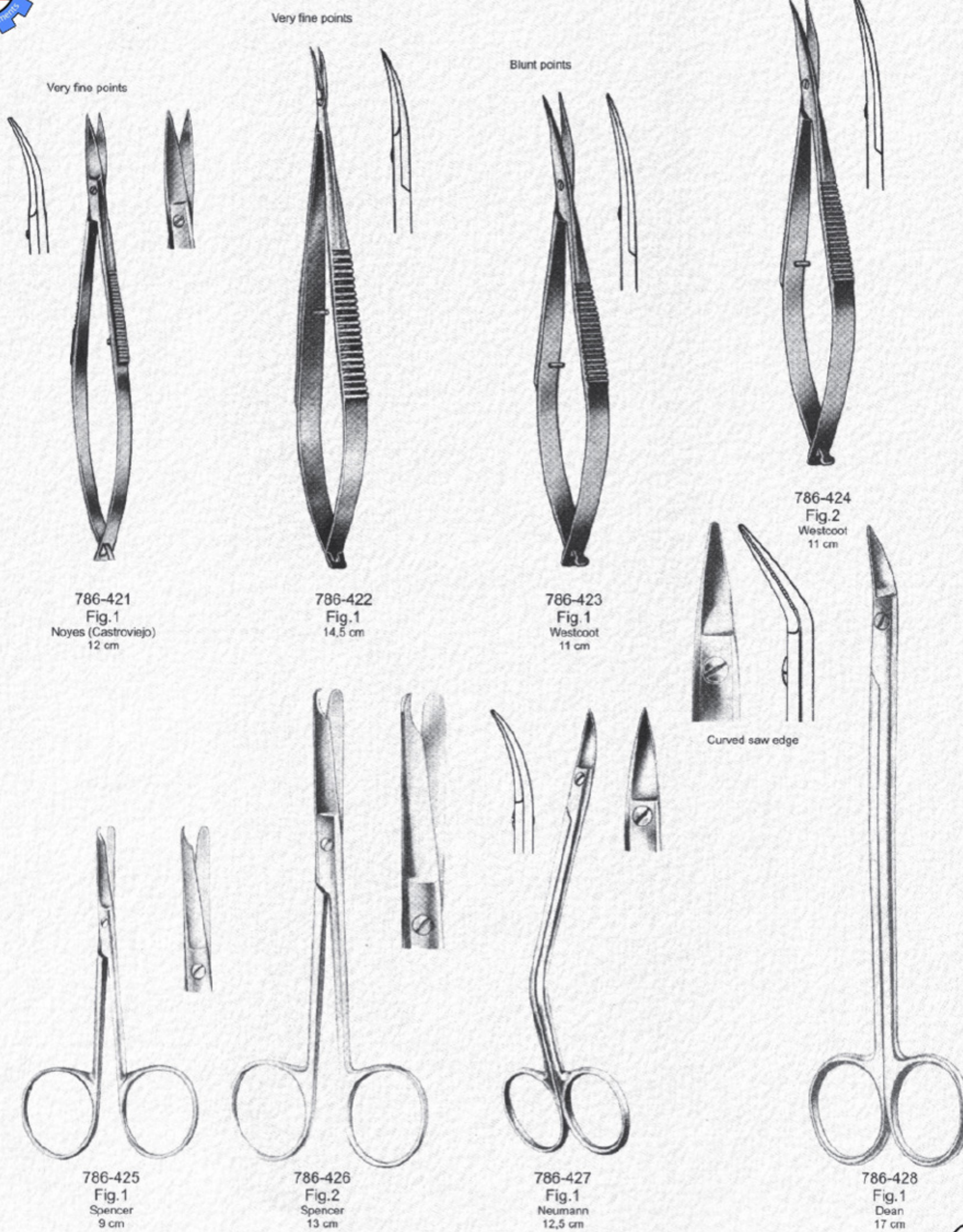

Very fine points

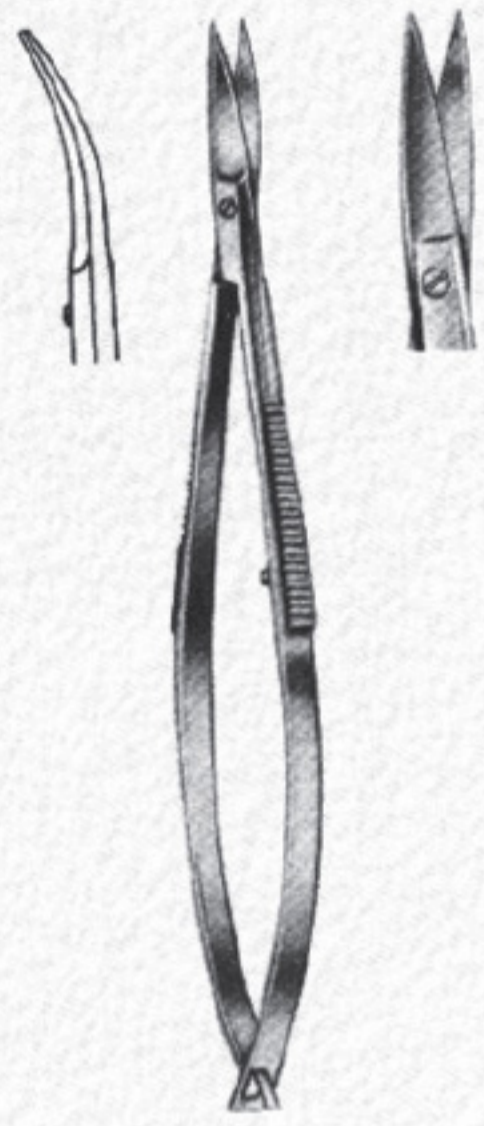

786-421
Fig.1
Noyes (Castroviejo)
12 cm

Very fine points

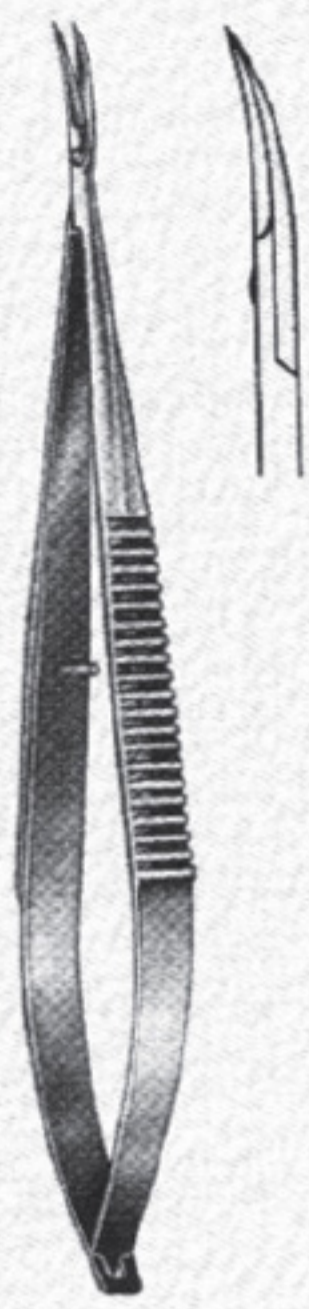

786-422
Fig.1
14.5 cm

Blunt points

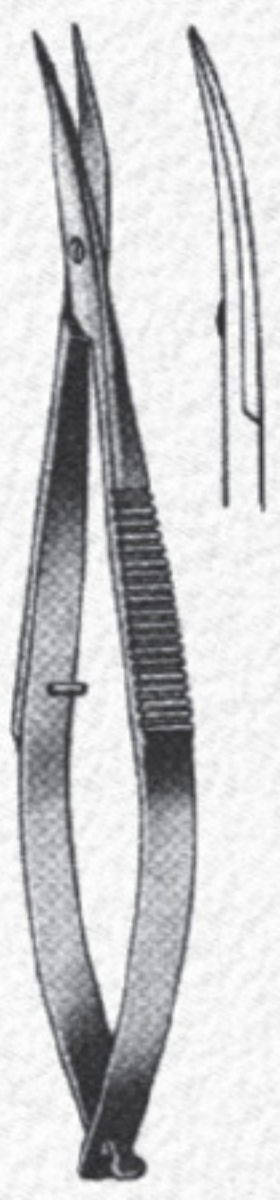

786-423
Fig.1
Westcott
11 cm

Sharp points

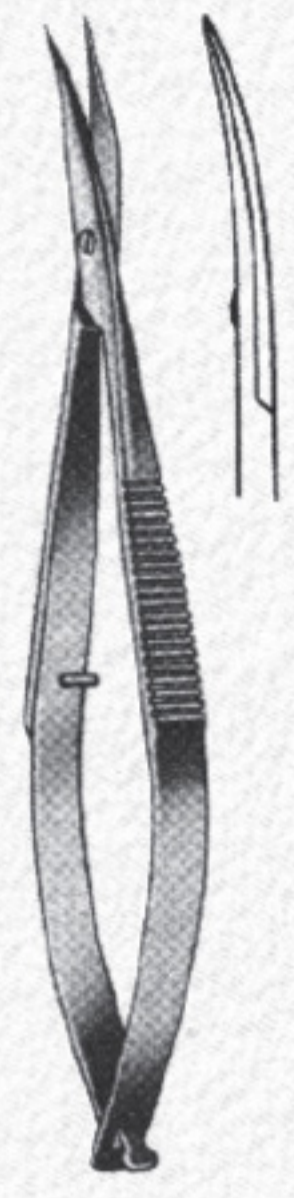

786-424
Fig.2
Westcott
11 cm



Curved saw edge

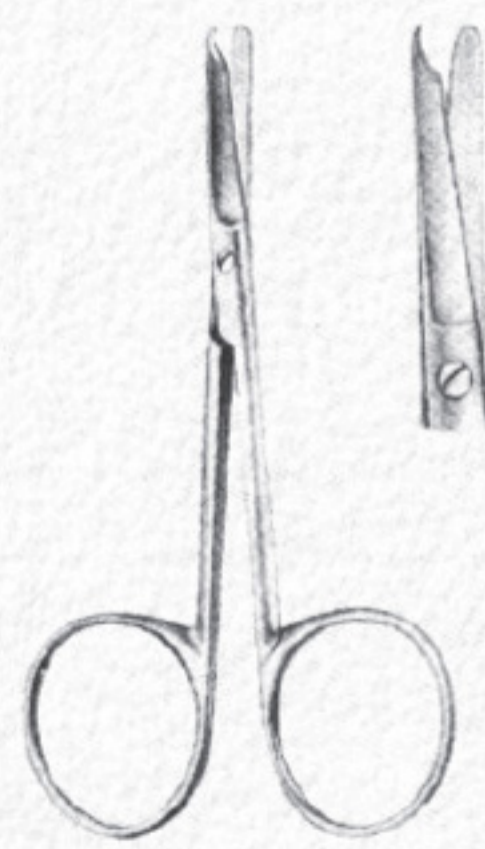

786-425
Fig.1
Spencer
9 cm

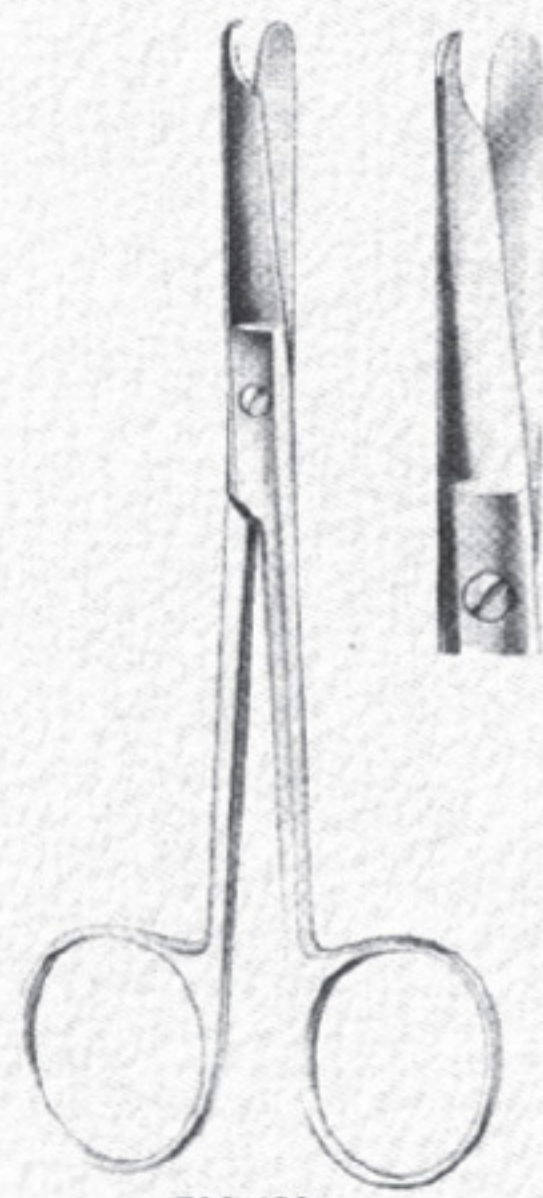

786-426
Fig.2
Spencer
13 cm



786-427
Fig.1
Neumann
12.5 cm

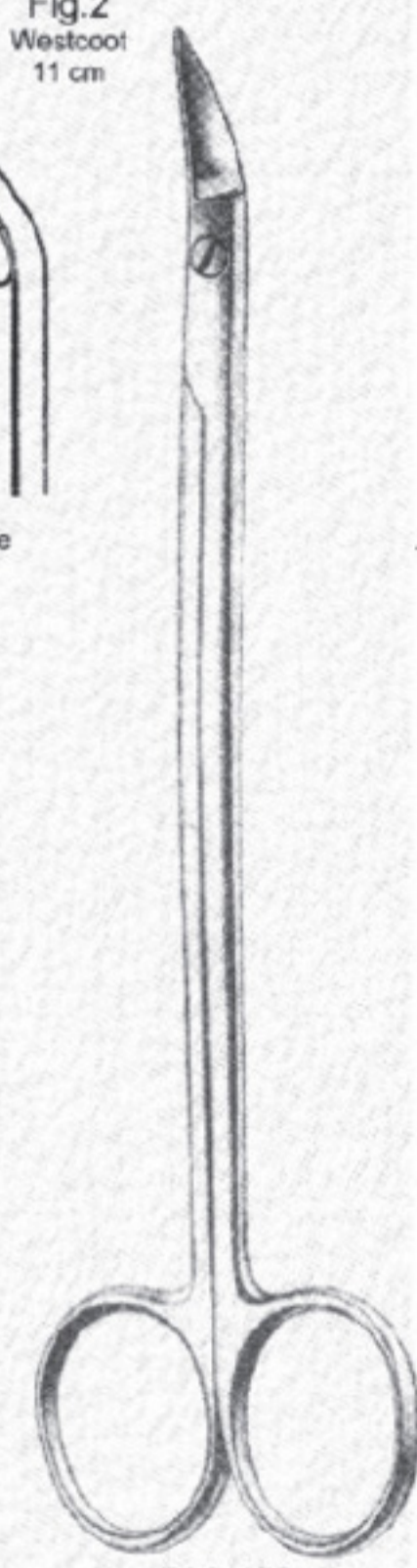

786-428
Fig.1
Dean
17 cm



Gum Scissors

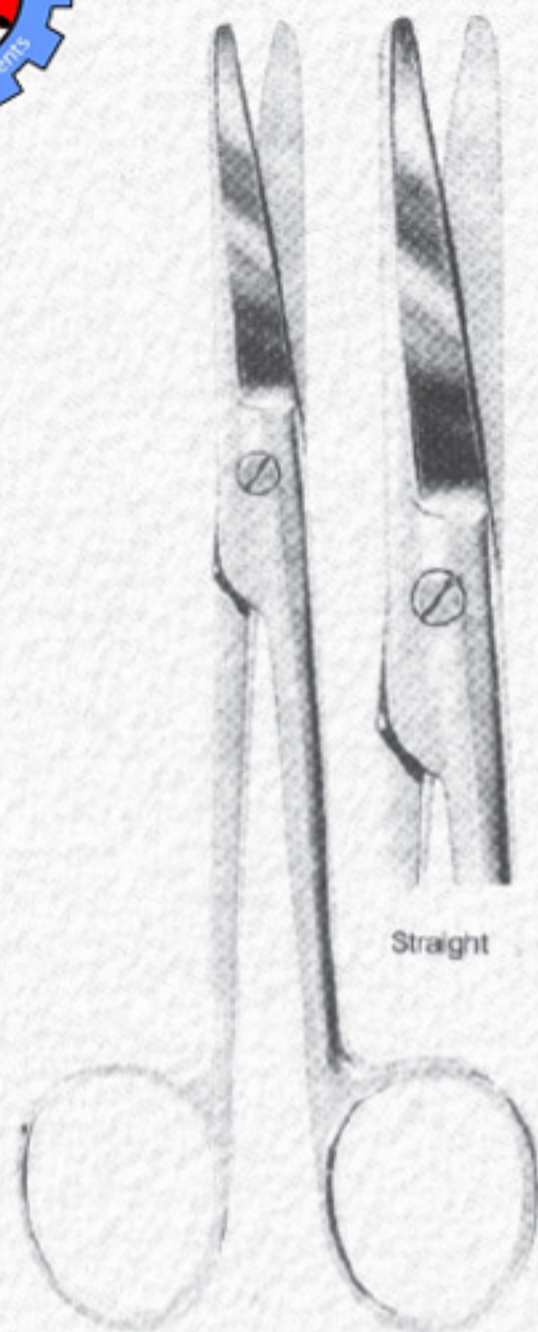

Straight

786-429
Fig.1
Mayo
14,5 cm

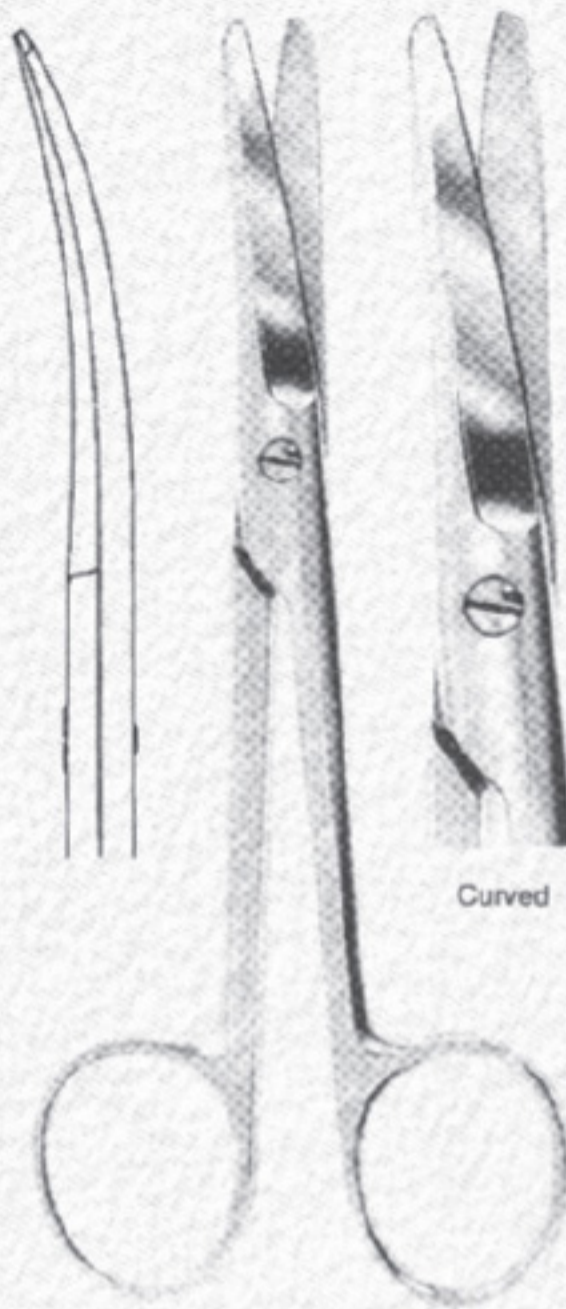

Curved

786-430
Fig.2
Mayo
14,5 cm

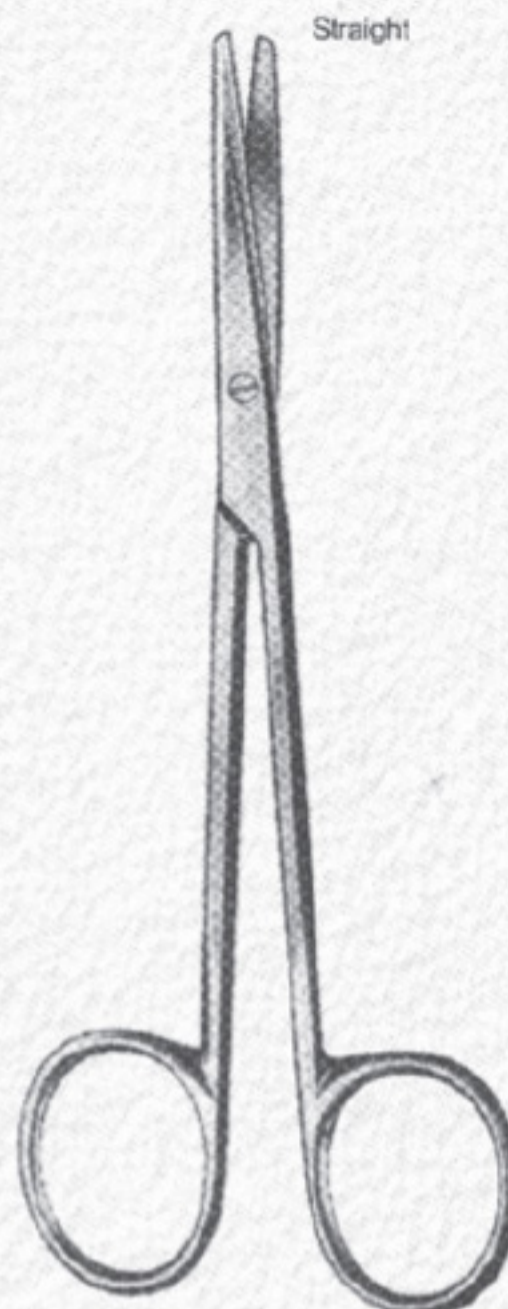

Straight

786-431
Fig.1
Metzenbaum
14,5 cm

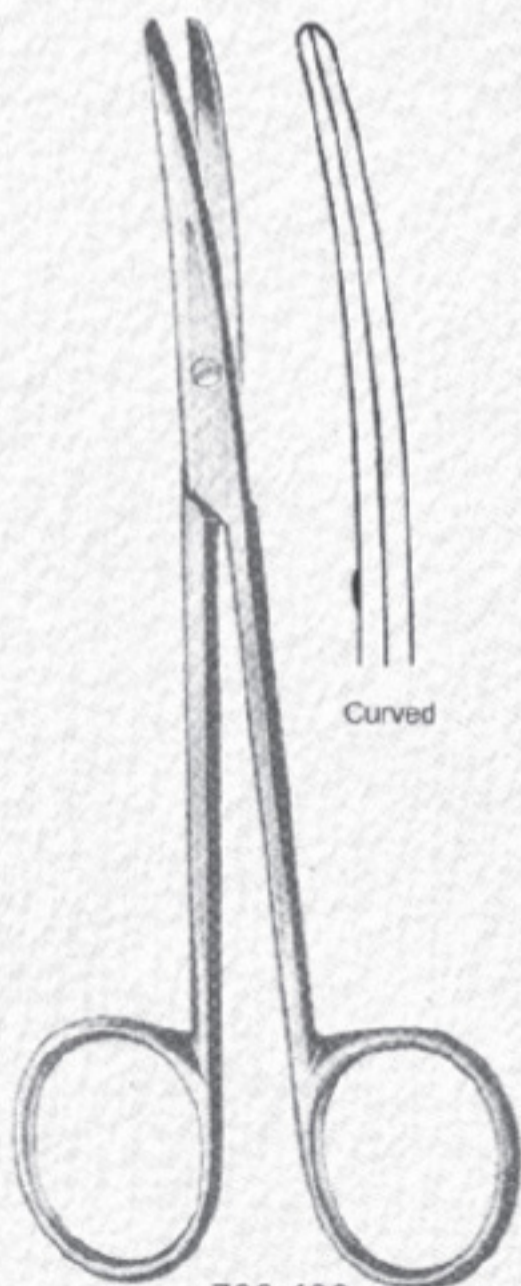

Curved

786-432
Fig.2
Metzenbaum
14,5 cm

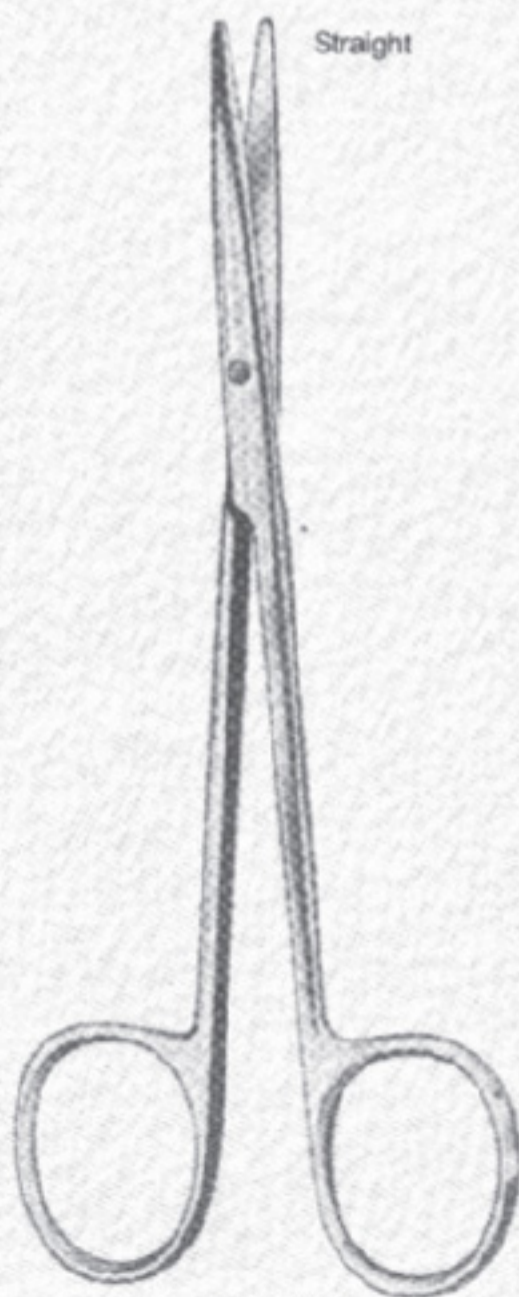

Straight

786-433
Fig.1
Metzenbaum-Delicate
14,5 cm

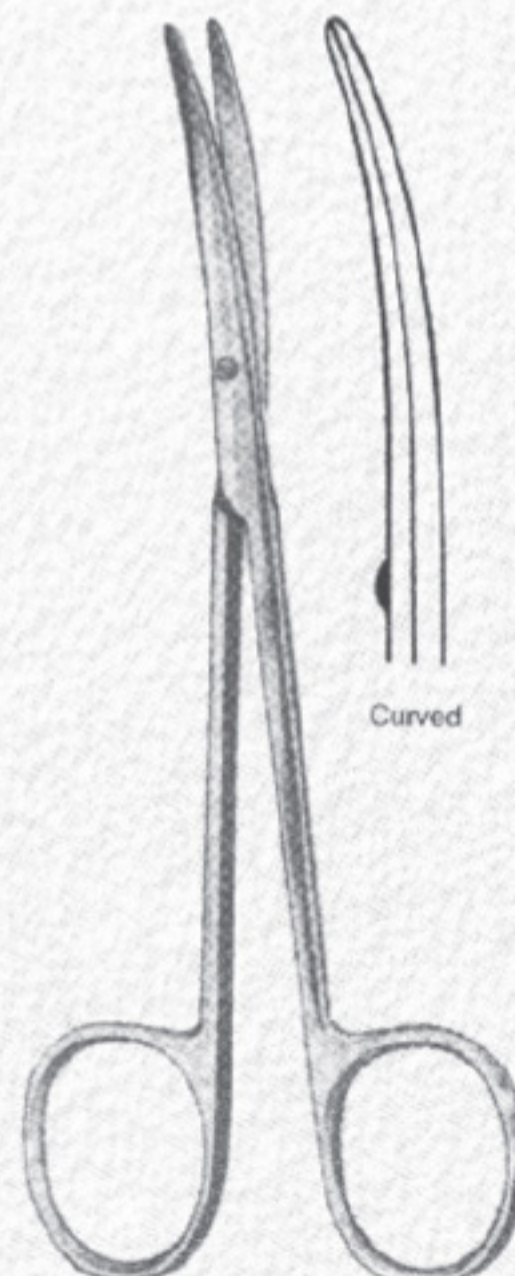

Curved

786-434
Fig.2
Metzenbaum-Delicate
14,5 cm



Haemostatic Forceps

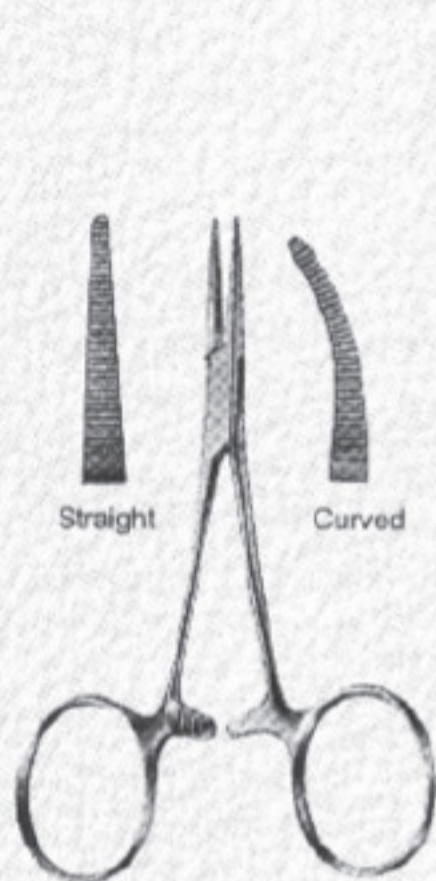

786-435
Baby-Mosquito
10 cm

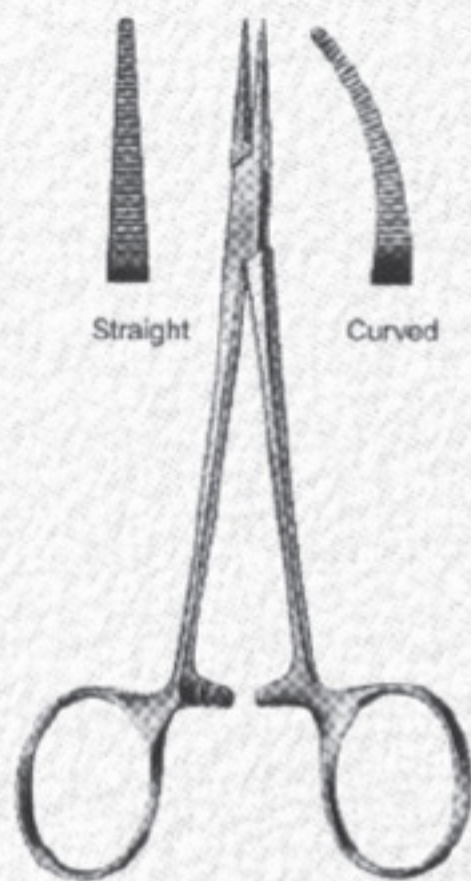

786-436
Micro-Halsted
12.5 cm

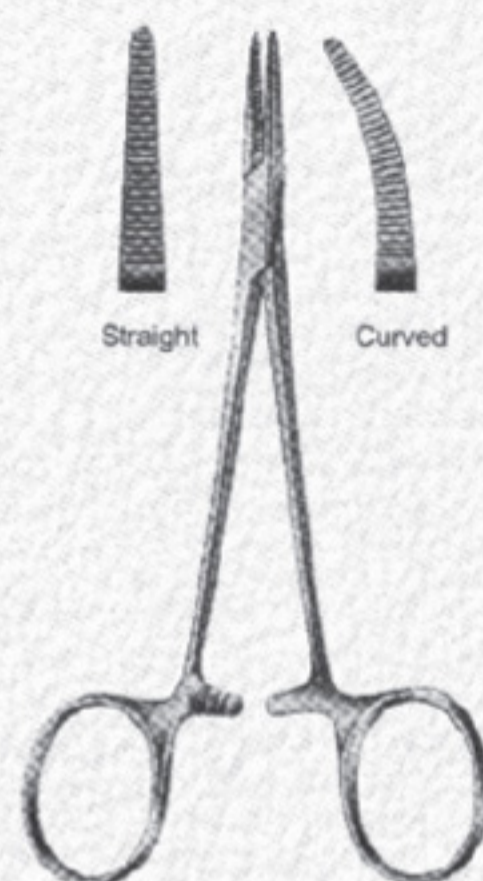

786-437
Halsted-Mosquito
12.5 cm

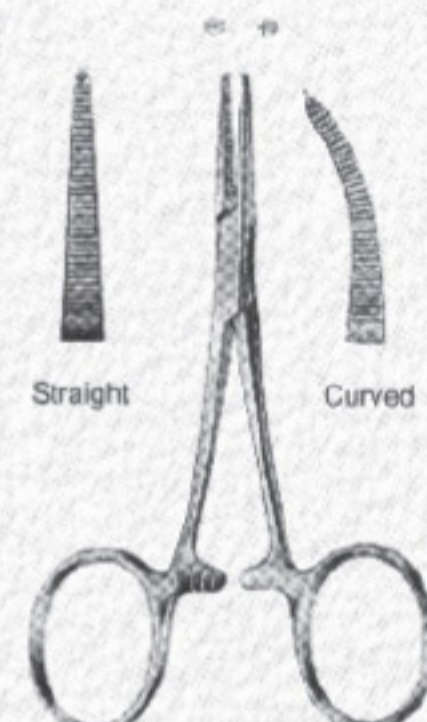

786-438
Baby-Mosquito
10 cm

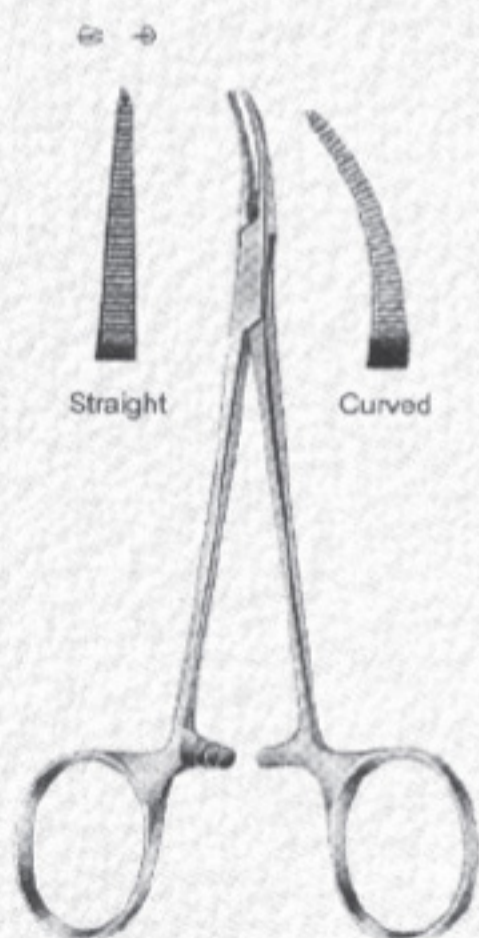

786-439
Micro-Halsted
12.5 cm

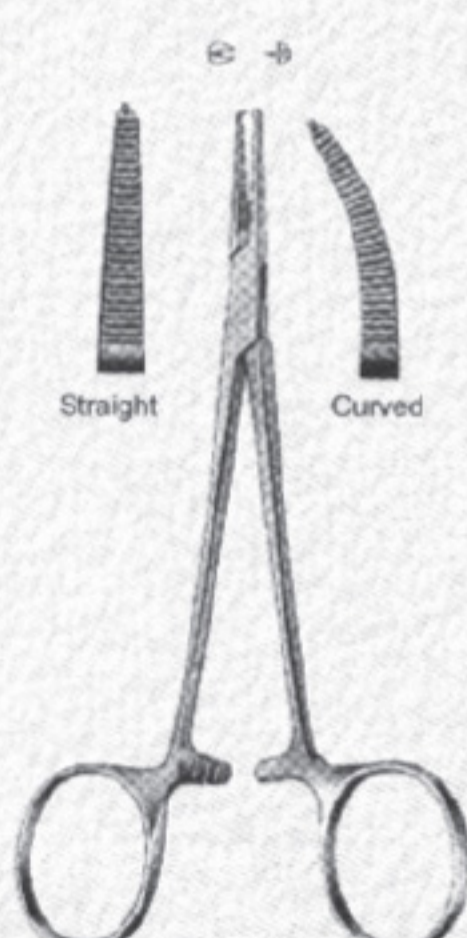

786-440
Halsted-Mosquito
12.5 cm

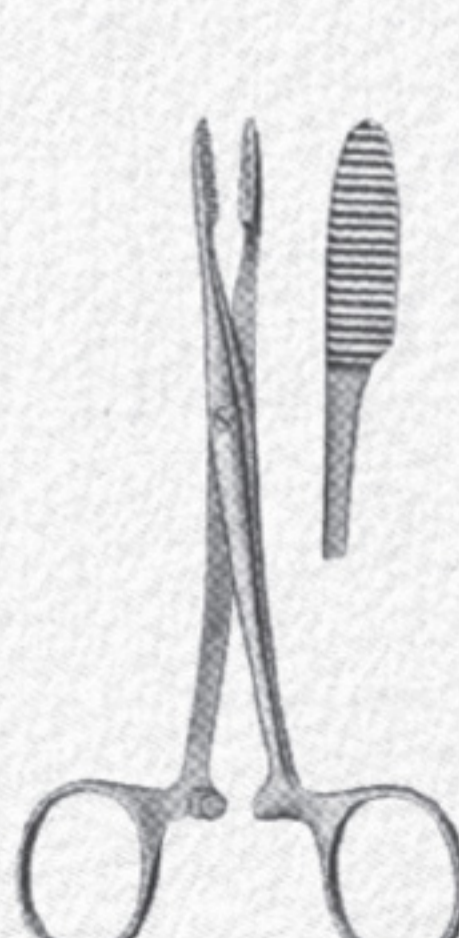

786-441
Pean
12.5 cm, 5"

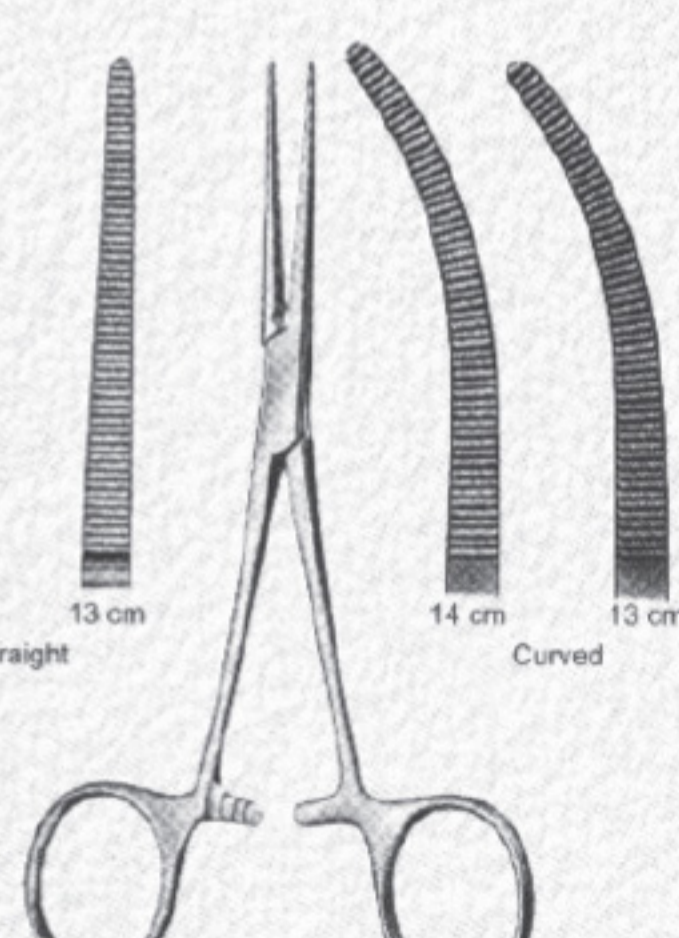

786-442
Pean
13 cm



Haemostatic Forceps

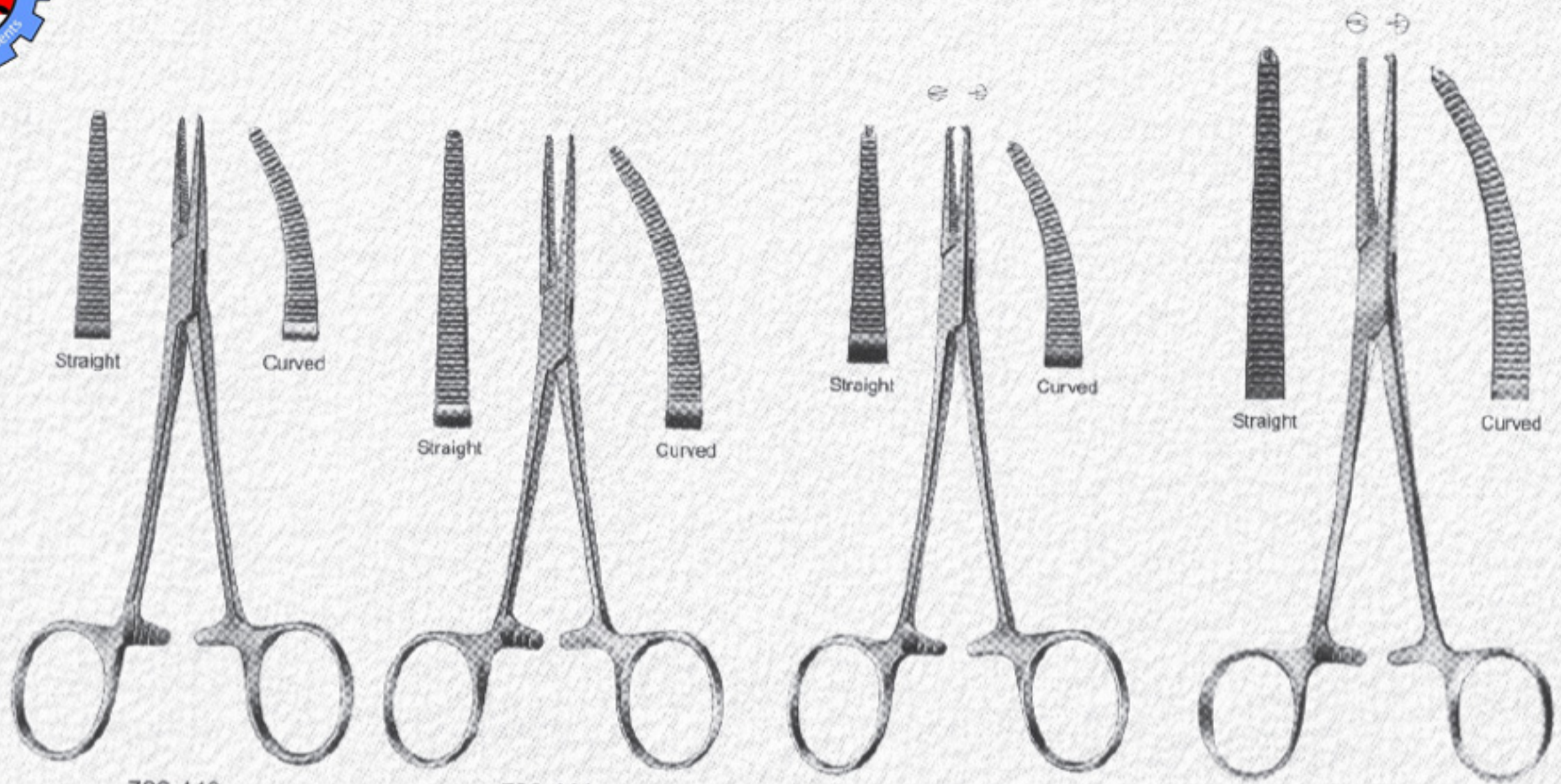

786-443
Baby-Crile (Pean)
14 cm

786-444
Crile
14 cm

786-445
Baby-Crile (Kocher)
14 cm

786-446
Crile (Kocher)
16 cm

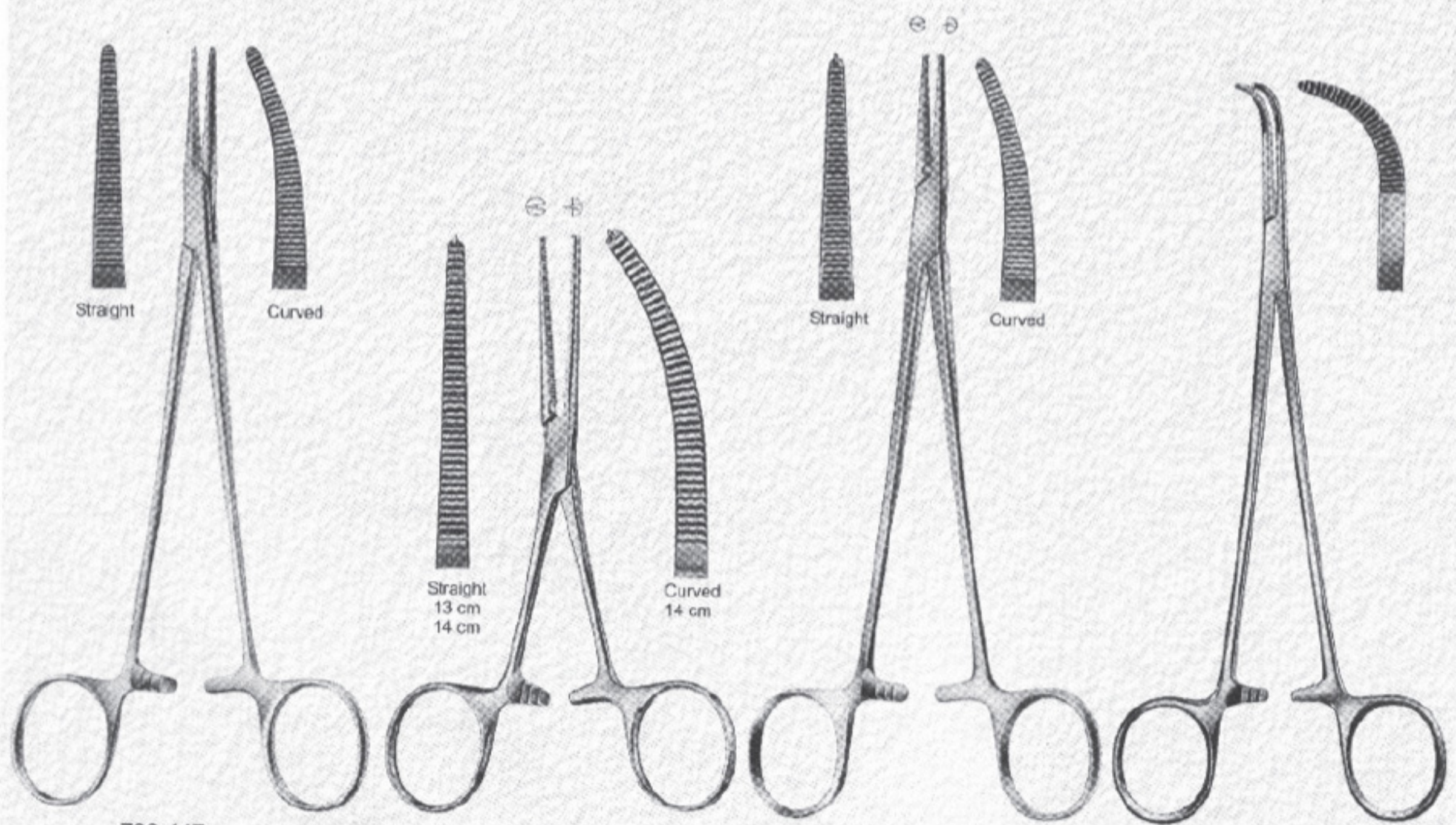

786-447
Halsted
18,5 cm

786-448
Kocher

786-449
Halsted
18,5 cm

786-450
Baby-Mixer
18 cm



Sponge and Dressing forceps

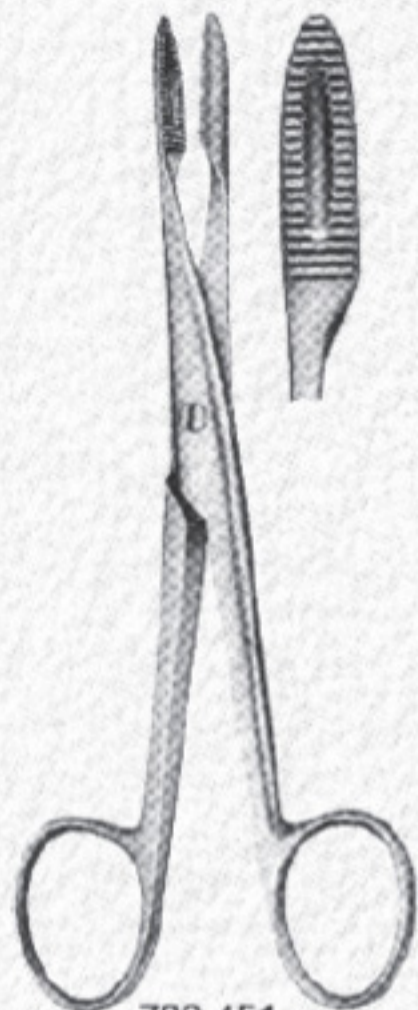

786-451
Without Ratchet
14,5 cm

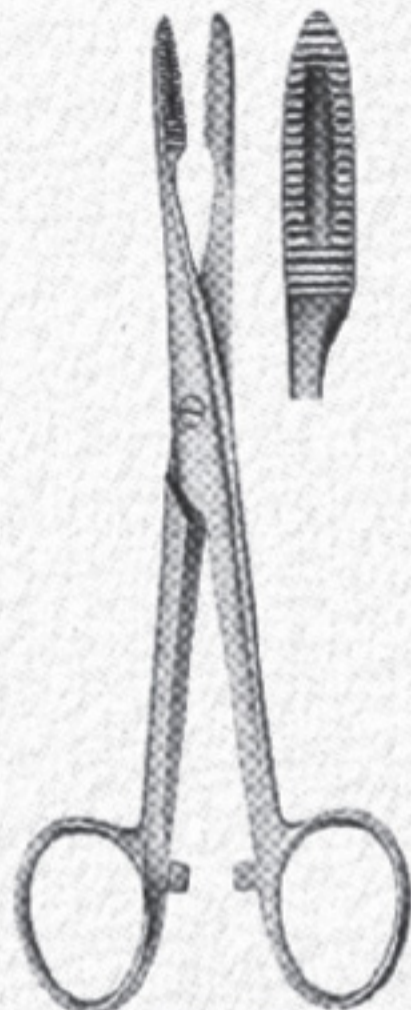

786-452
With Ratchet
14,5 cm

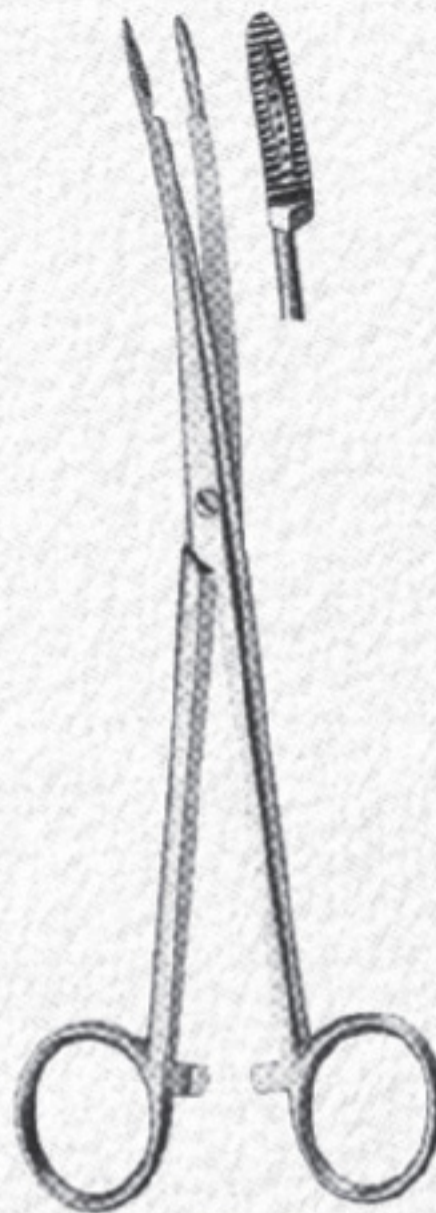

786-453
Curved
17,5 cm*

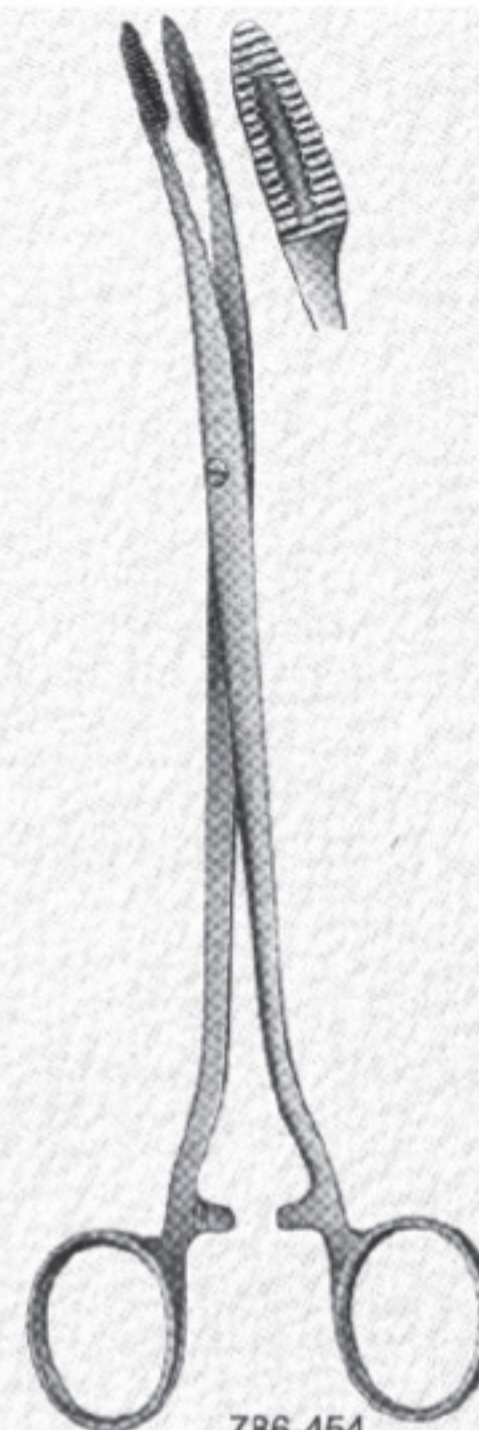

786-454
Curved
21 cm

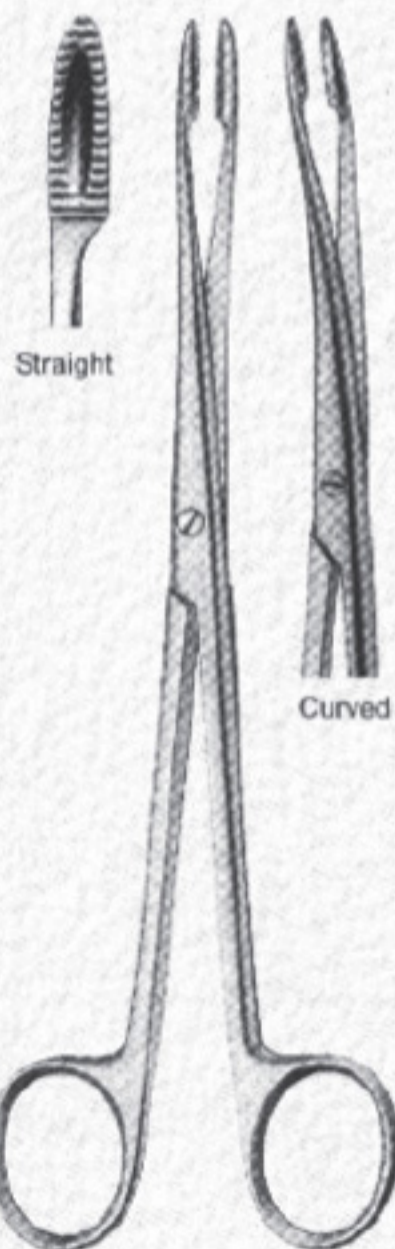

786-455
Without Ratchet
18 cm

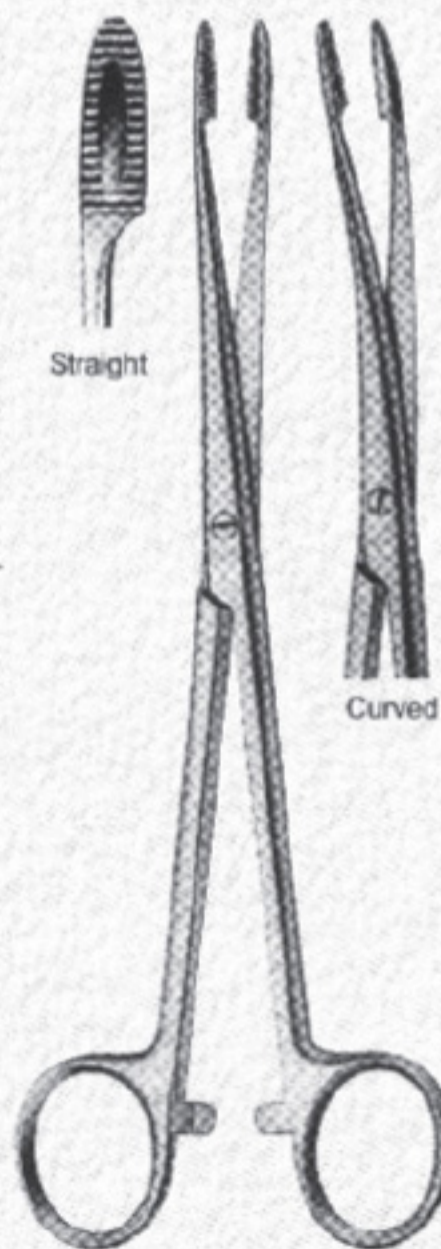

786-456
With Ratchet
18 cm

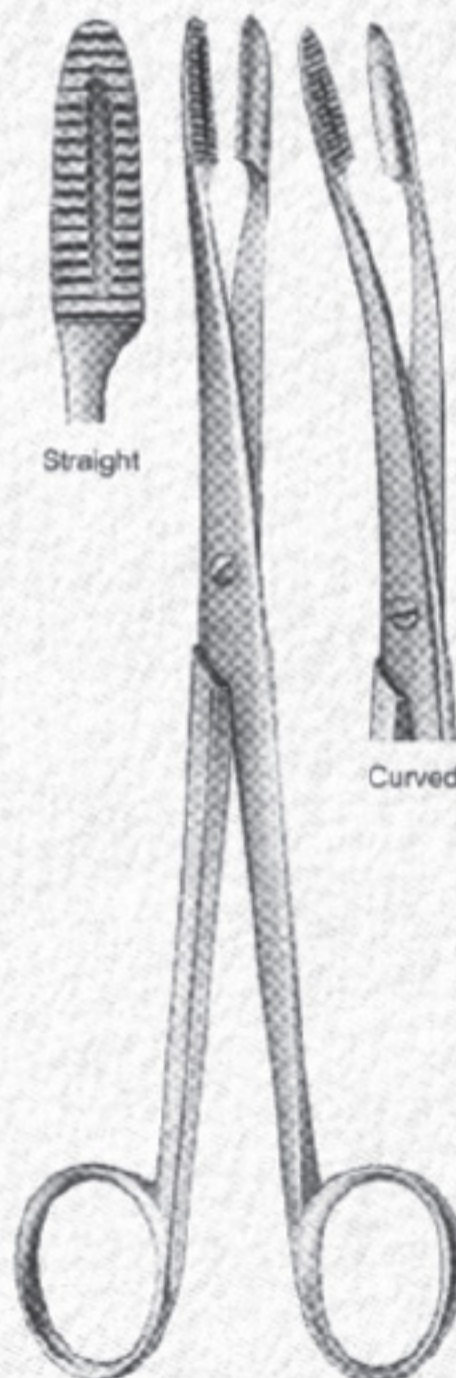

786-457
Without Ratchet
20 cm

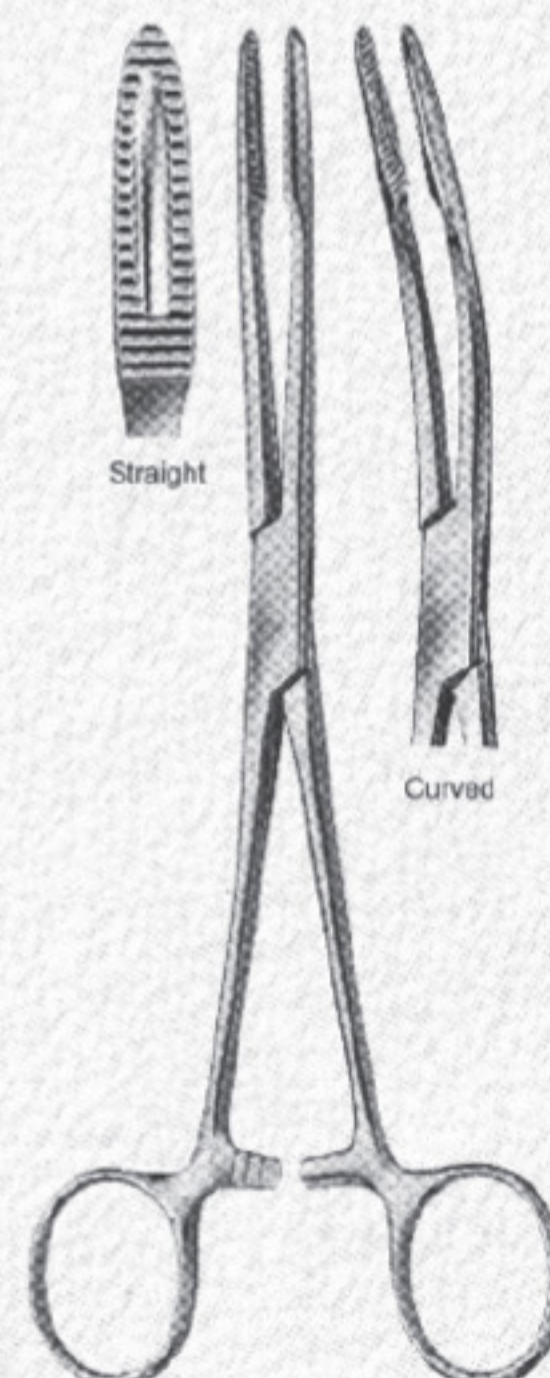

786-458
With Ratchet
20 cm



Needle Holders

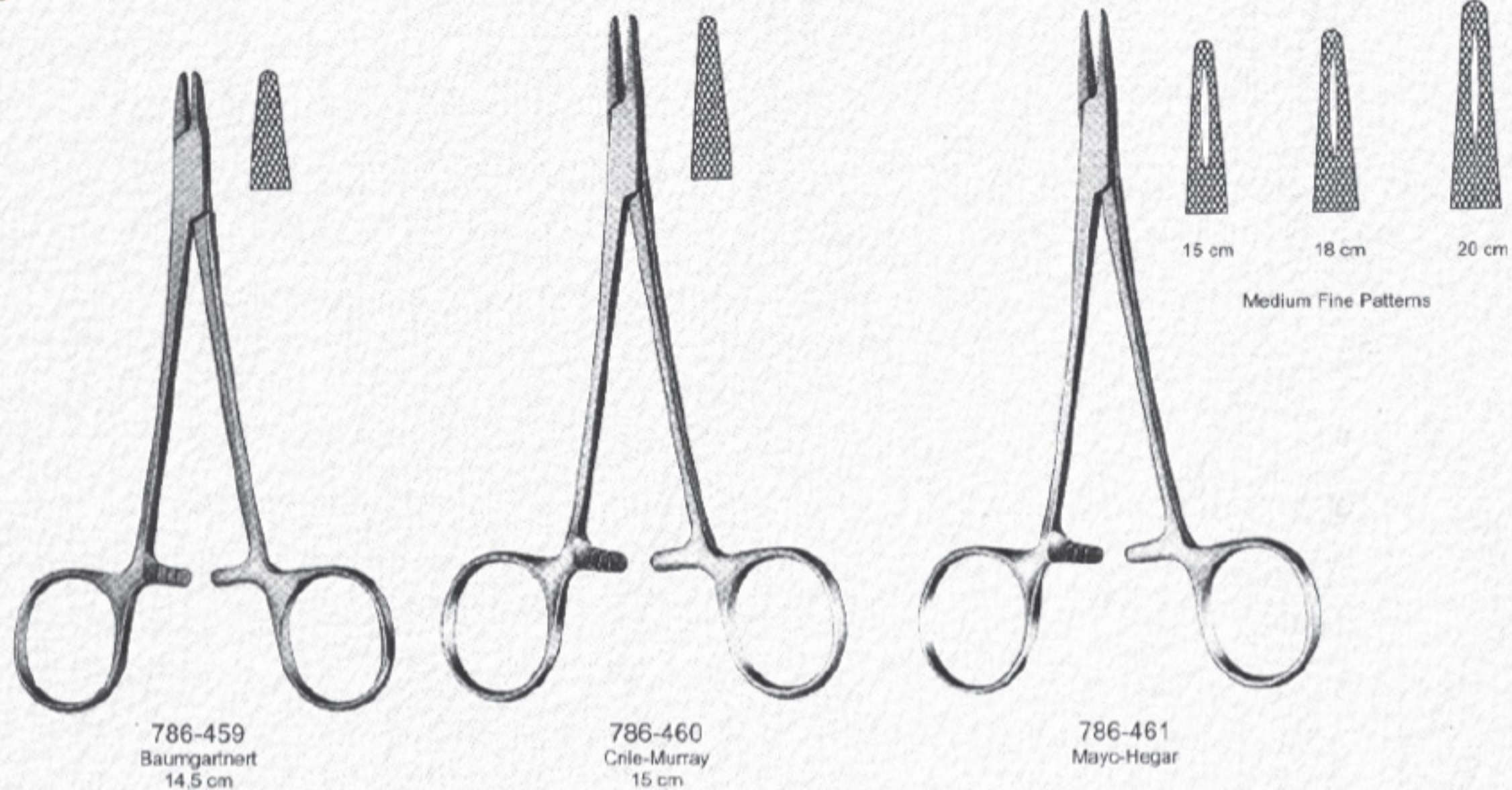

Designed for Frontal & Palate Suture

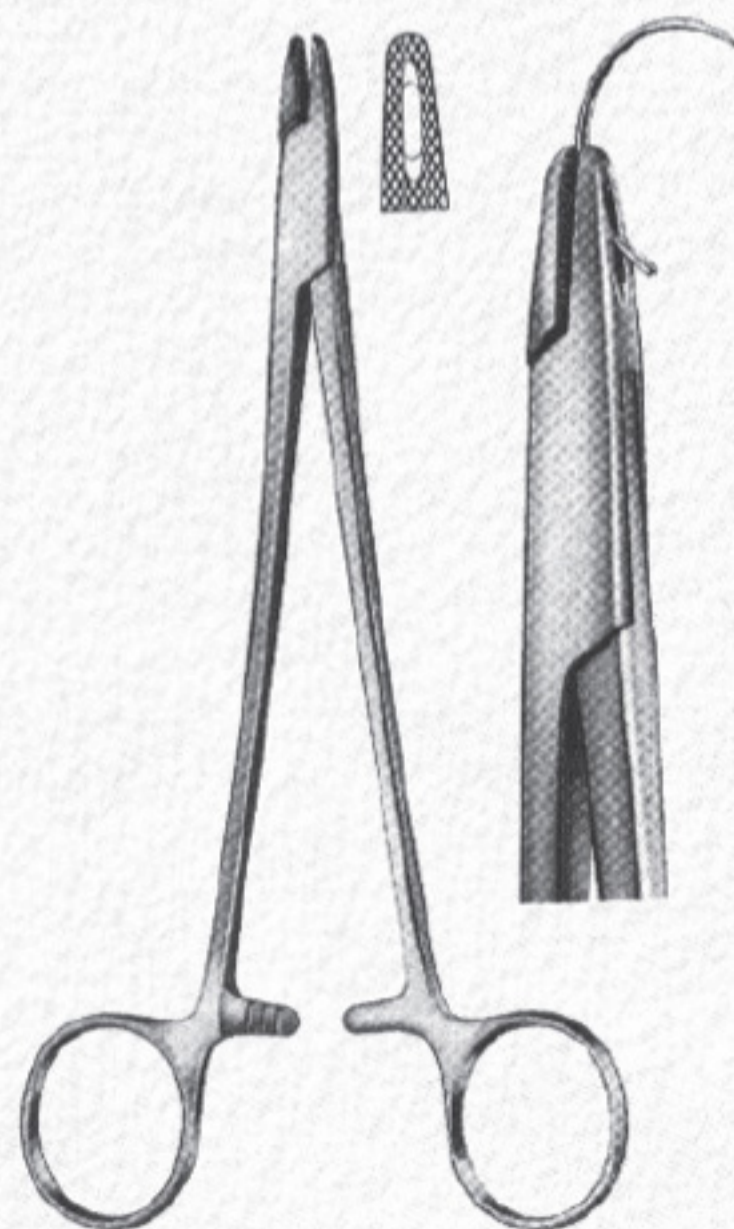

786-462
Adson
17,5 cm

Needle holders with Scissors

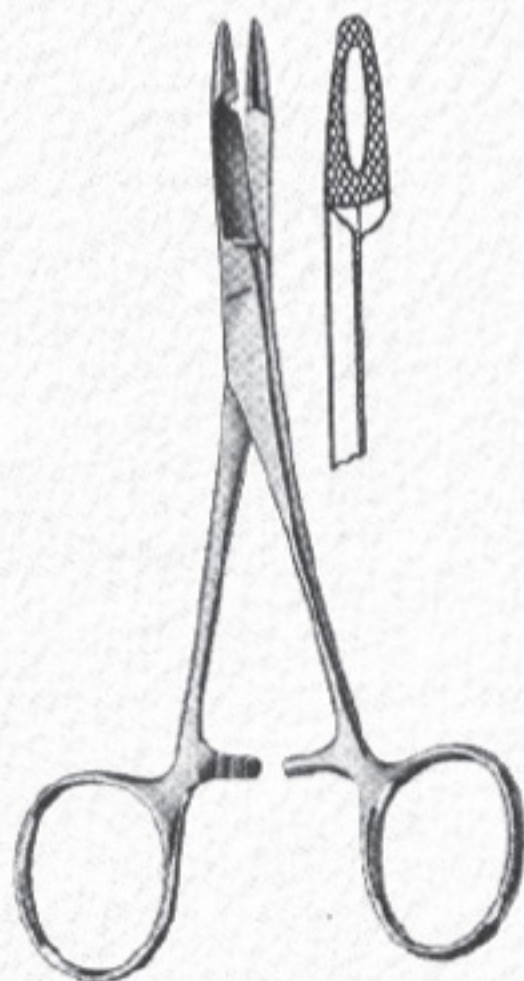

786-463
Heger-Olson
14 cm

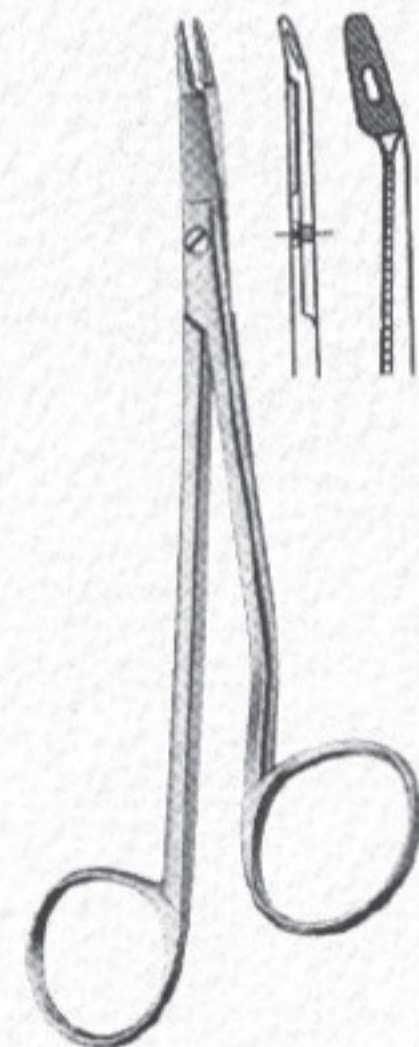

786-464
Gillies
15 cm



Needle Holders

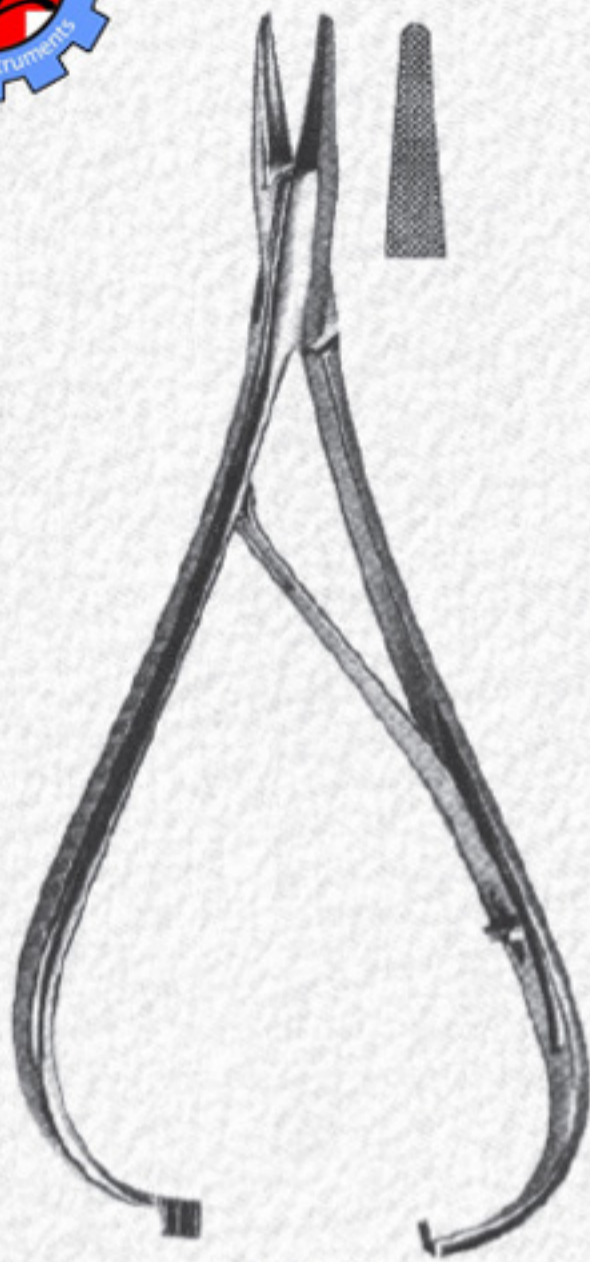

786-465
Mathieu
14 cm.

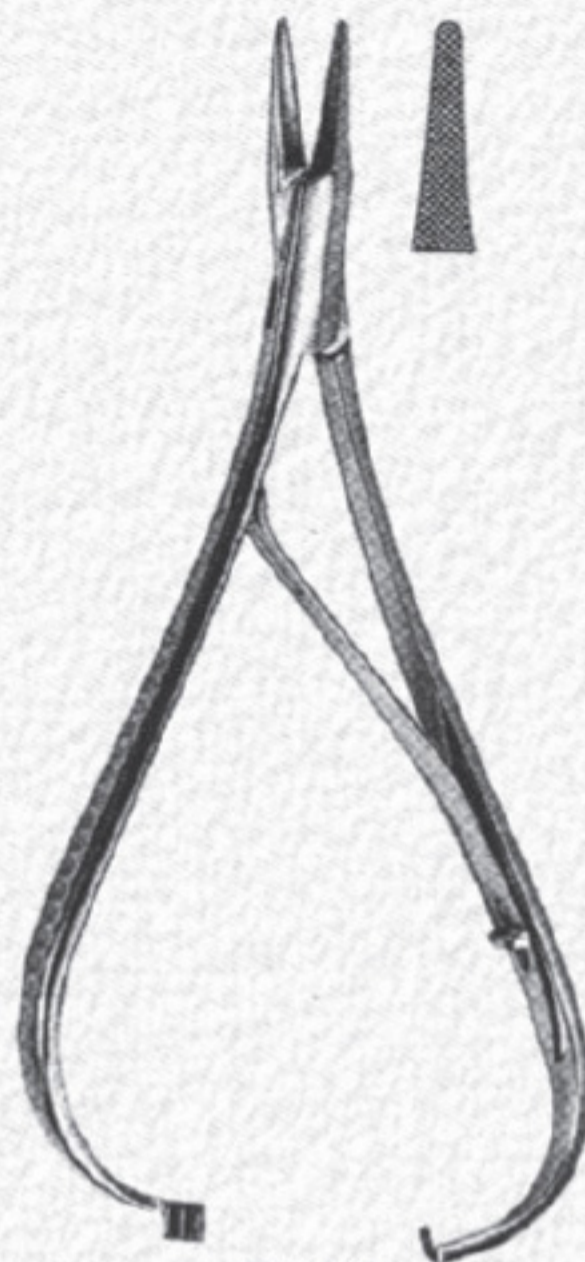

786-466
Mathieu
14 cm.

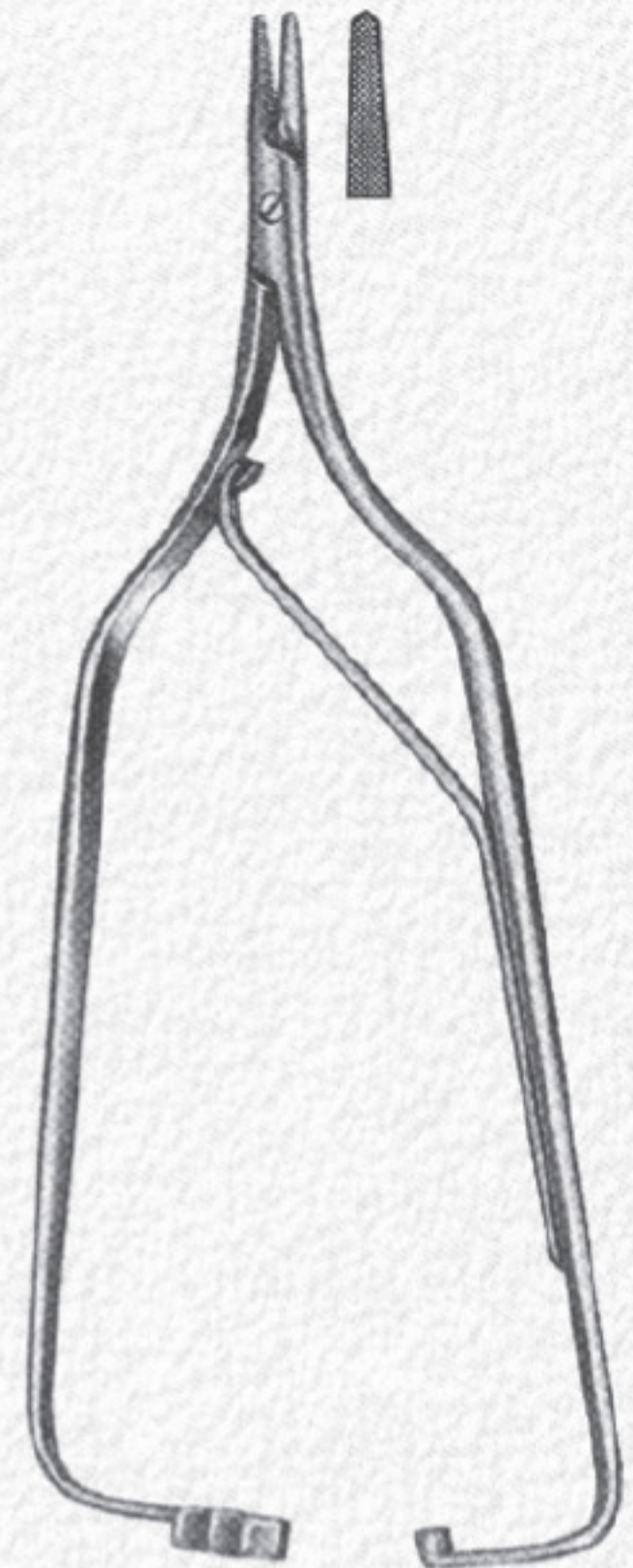

786-467
Boyrton
12 cm.

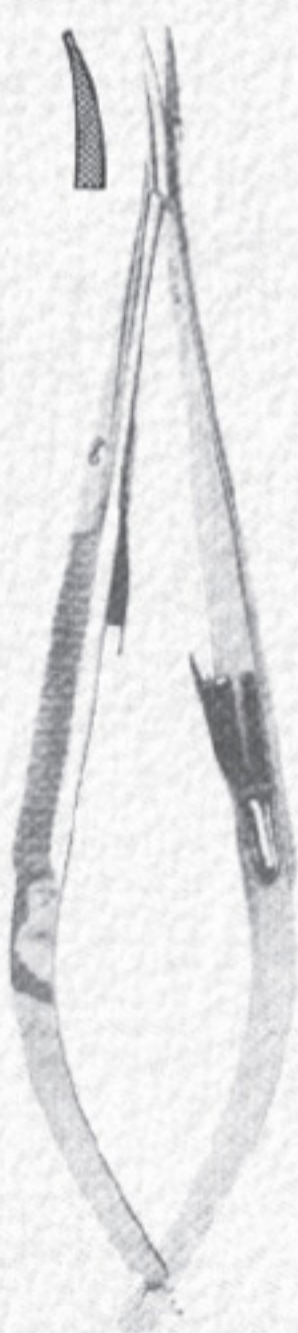

786-468
Castroviejo
14 cm.

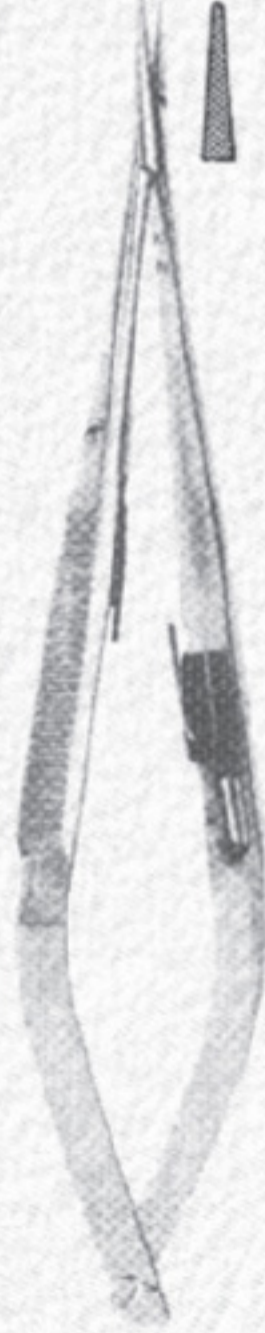

786-469
Castroviejo
14 cm.

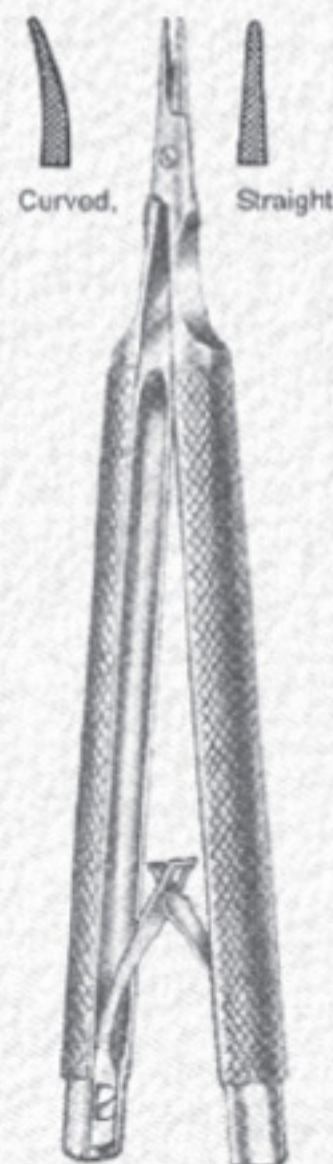

786-470
Castroviejo
13 cm.

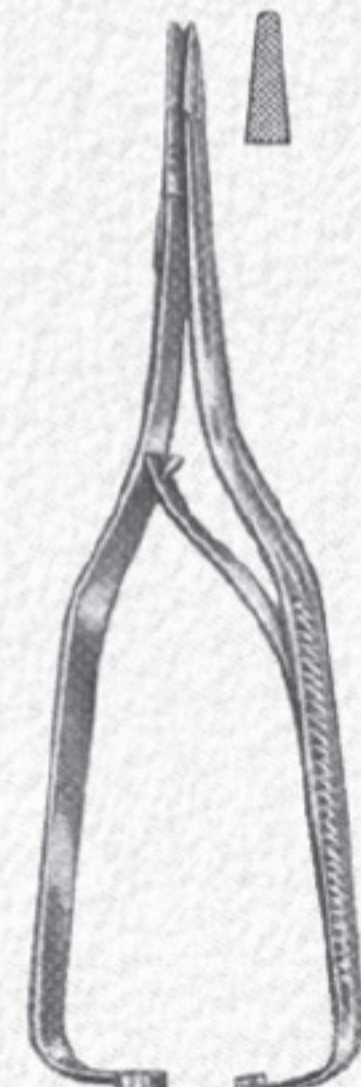

786-471
Arruga
16 cm.



Towel Clamps

Sterilizing Forceps for Sterile Instruments

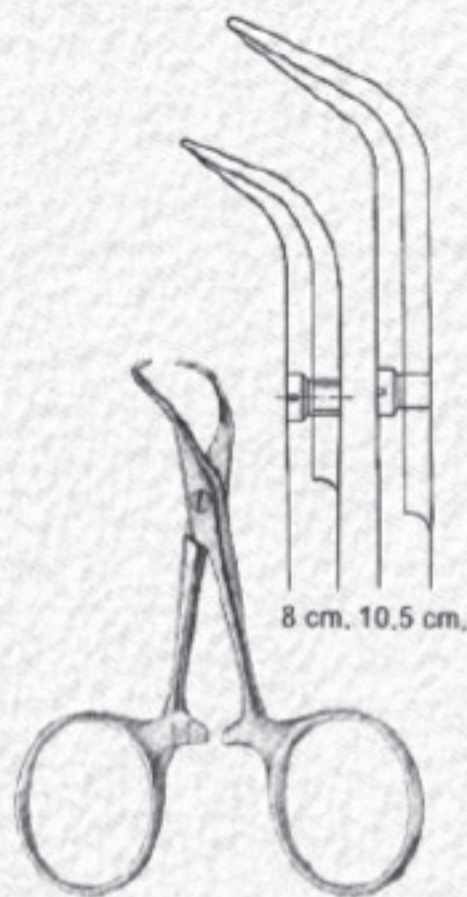

786-472
Backhaus

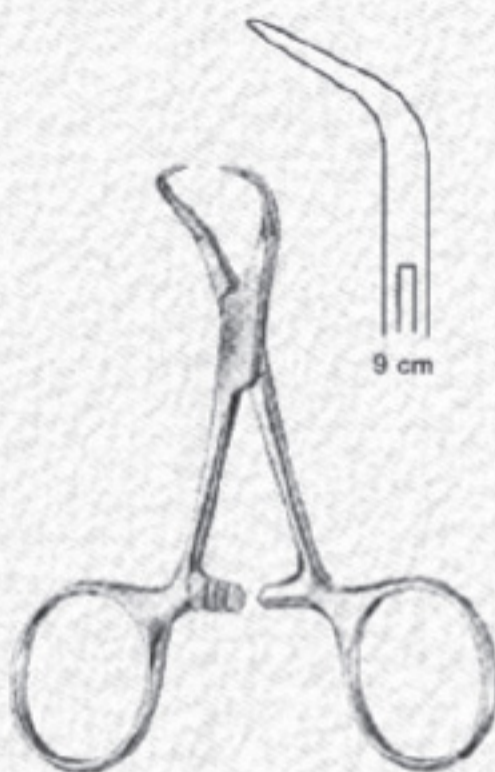

786-473
Backhaus

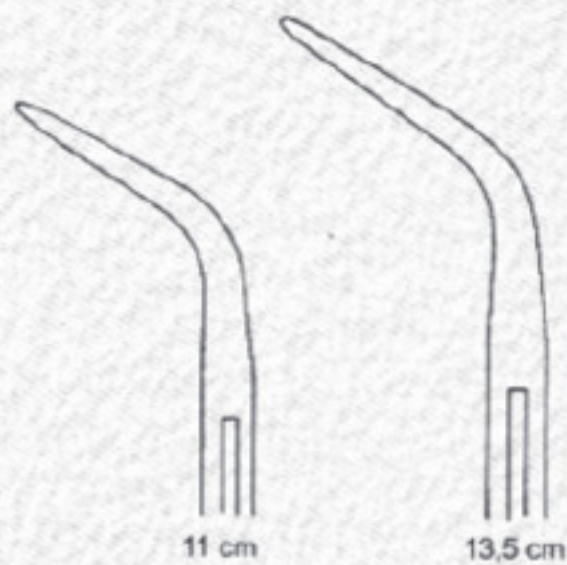

786-474
Backhaus-Kocher
13.5 cm

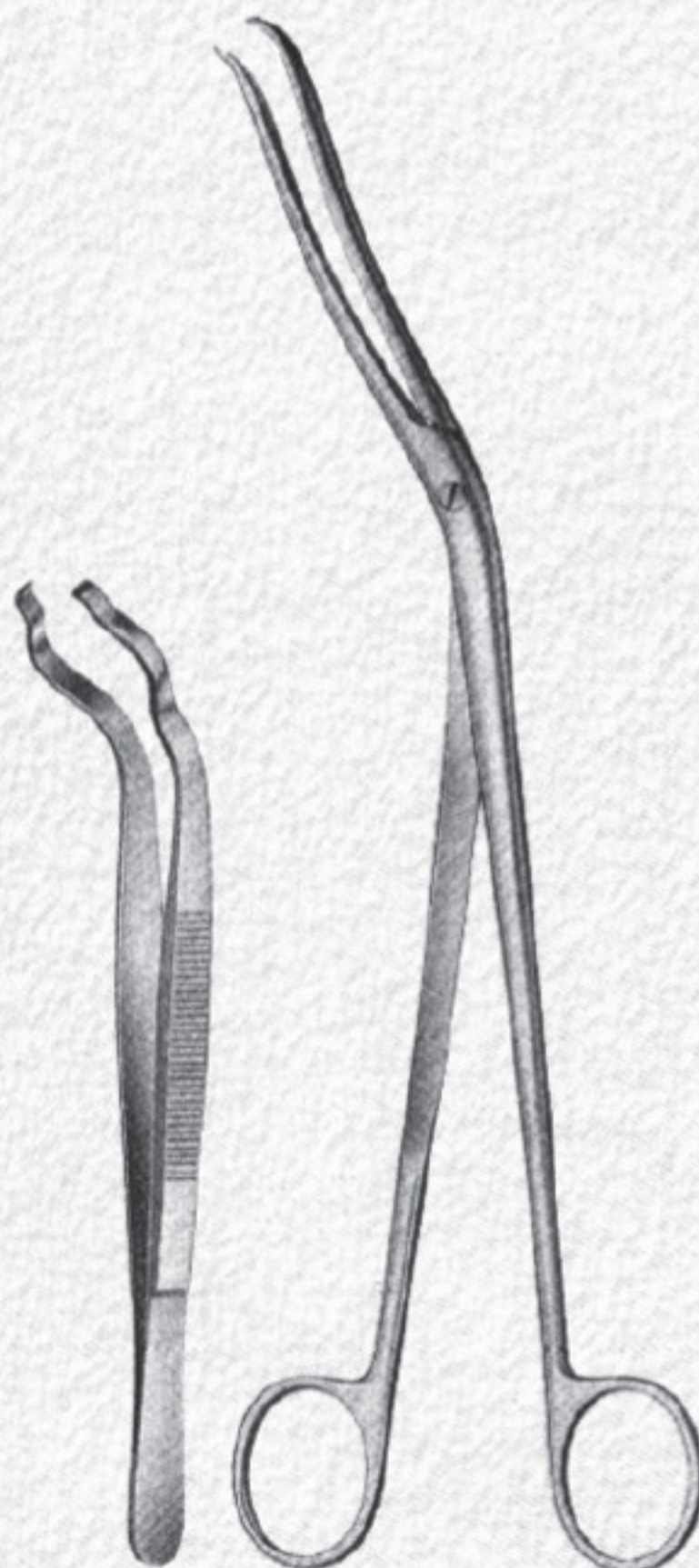

786-476
Cheattle
28 cm

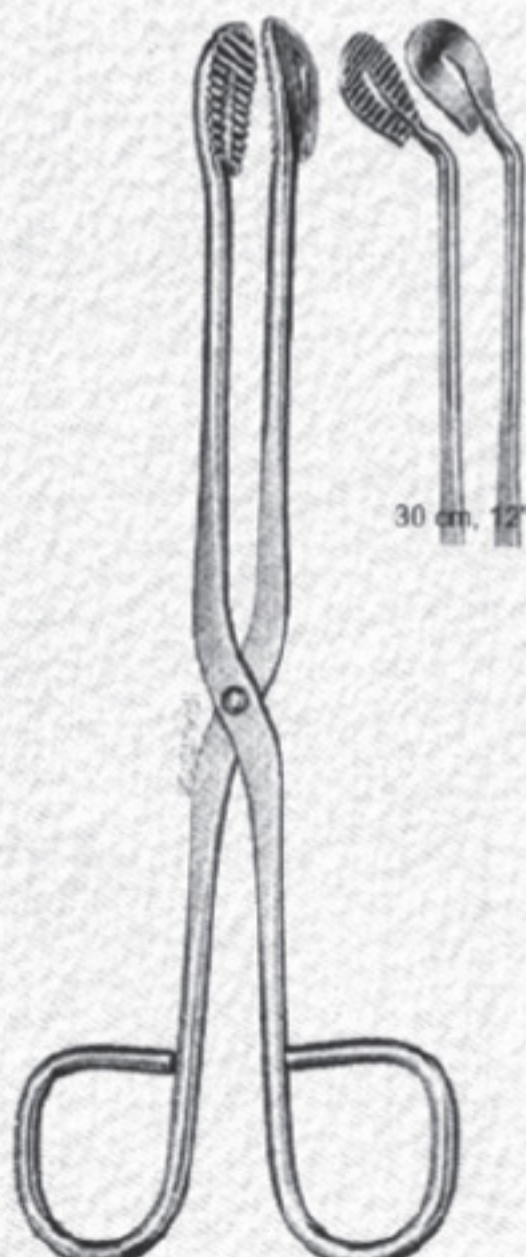

786-477
20 cm

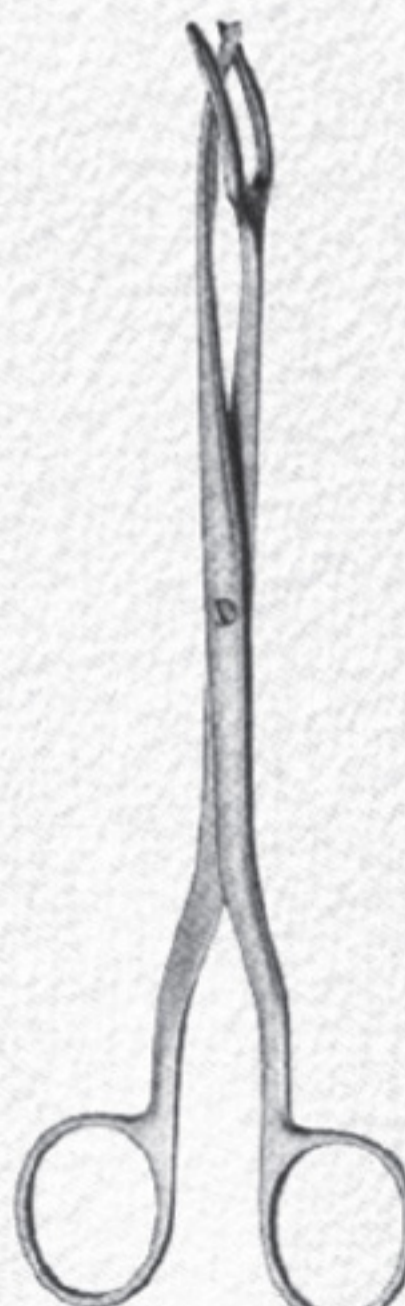

786-478
20 cm, 8"
30 cm, 12"

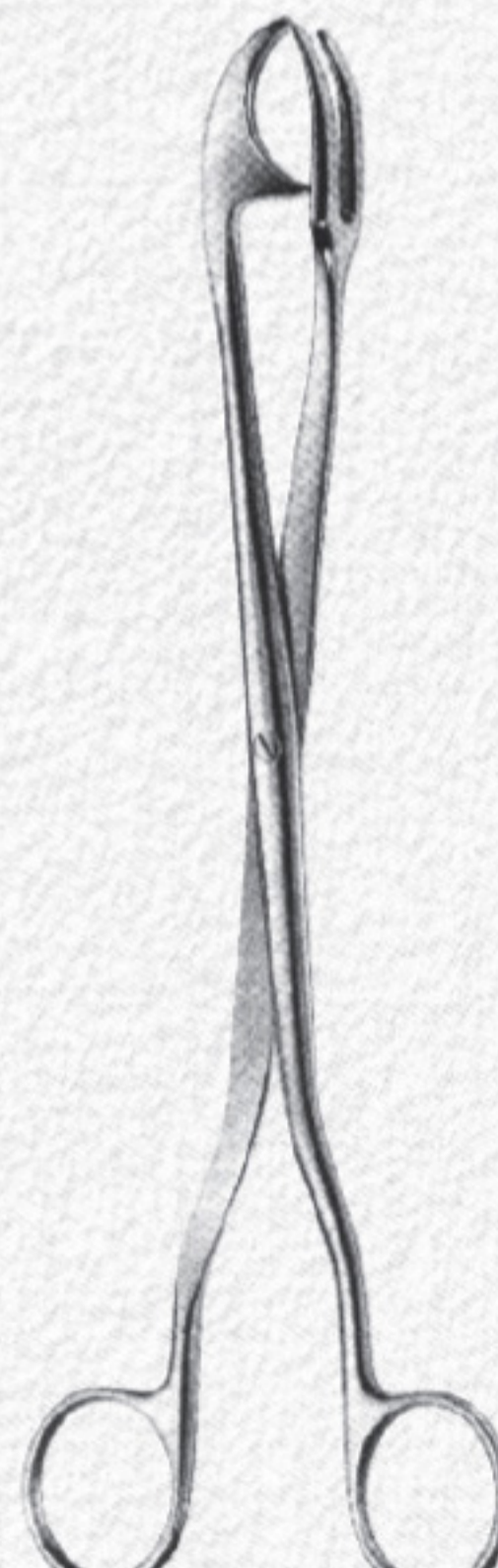

786-479
Rogge
23.5 cm

Skin Hook & Retractors

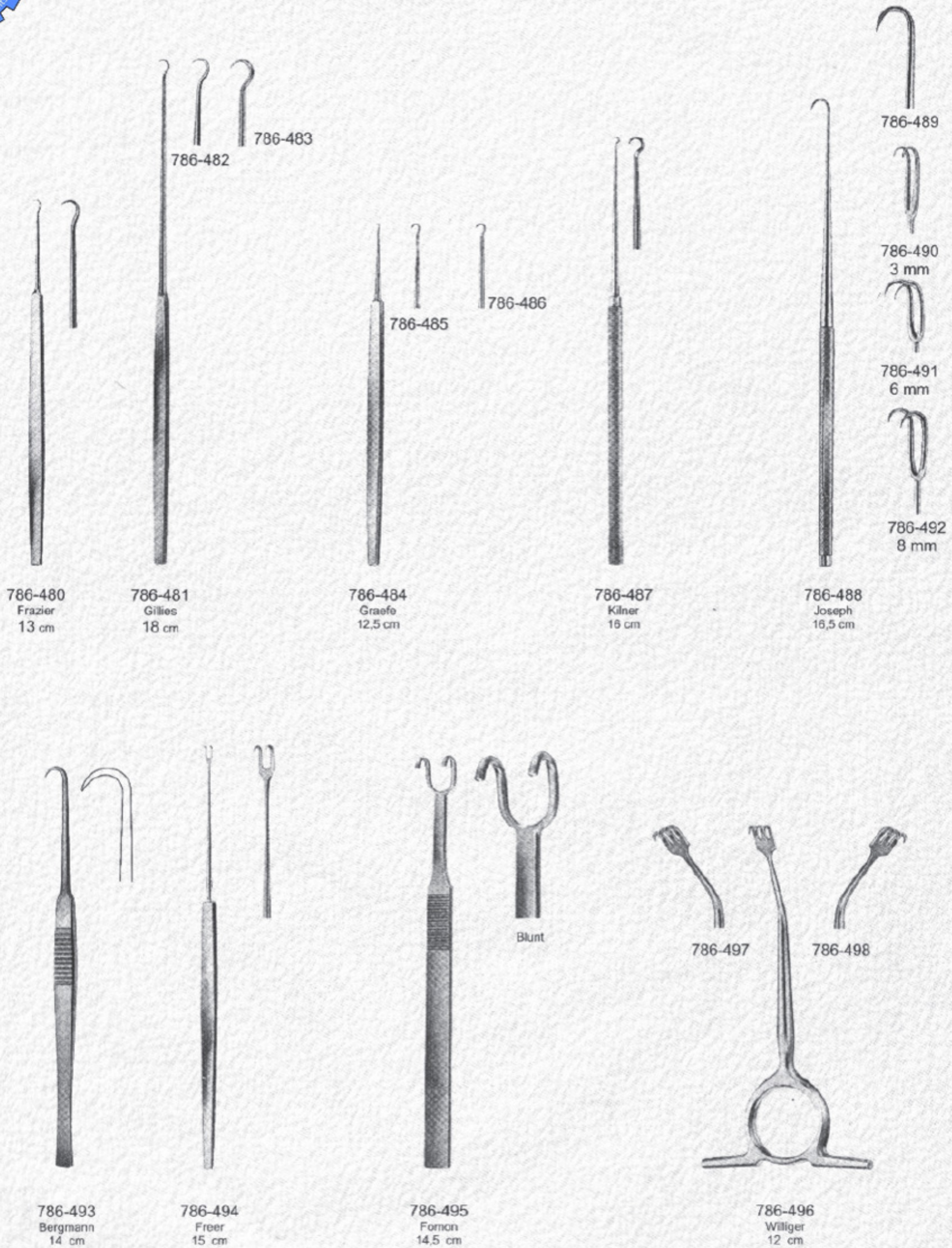



Retractors

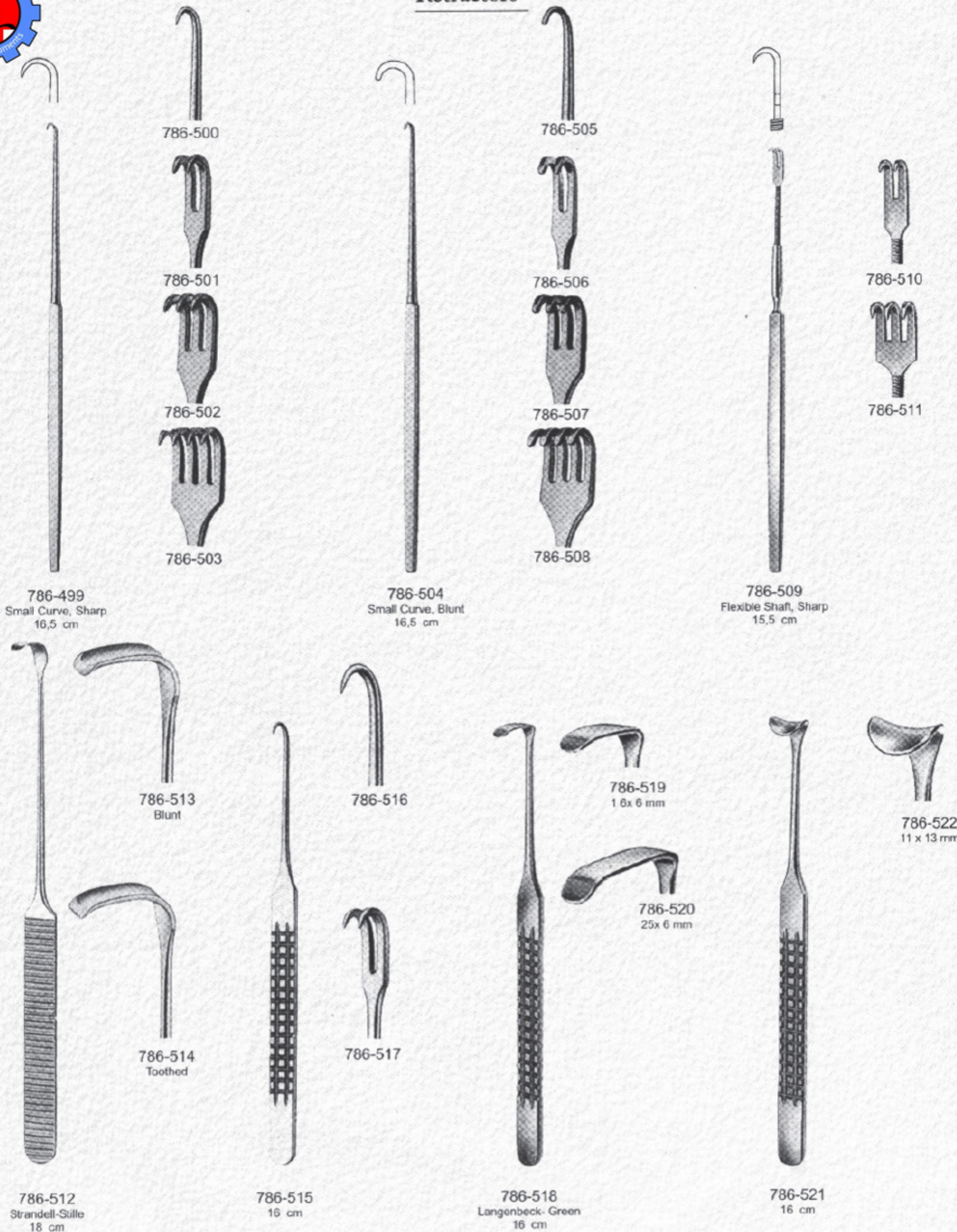



Retractors

25 x 10 mm
22 x 10 mm



28 x 12 mm
32 x 12 mm

786-523
Farabeuf
12,5 cm



786-529
30 x 10 mm

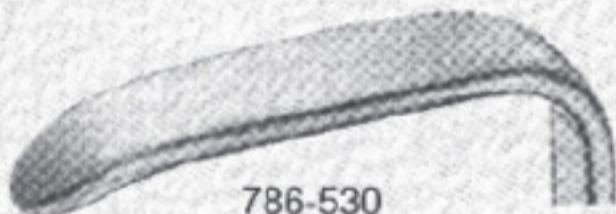

786-530
40 x 10 mm



786-531
43 x 13 mm

23 x 16 mm
20 x 16 mm



24 x 16 mm
28 x 16 mm

786-524
Farabeuf
15 cm

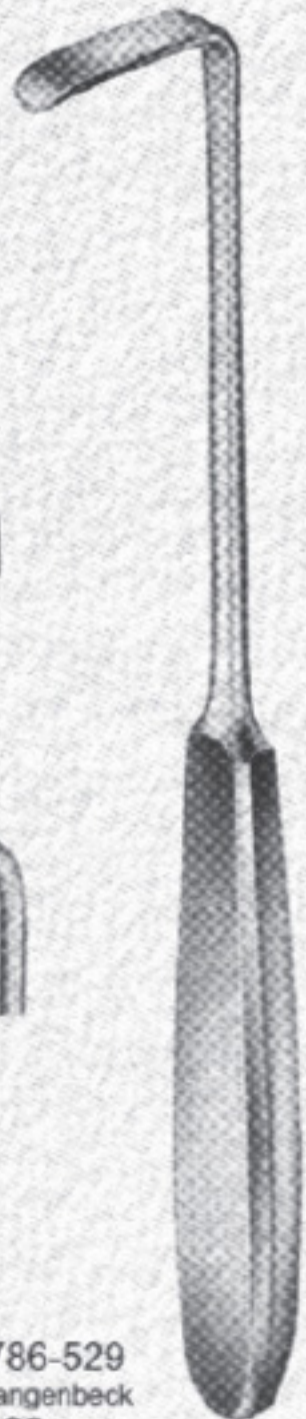

786-529
Langenbeck
23 cm

786-526
786-527
786-528



786-525
Roux - Set
16,5 cm
Consisting of :
786-526 19 x 22 mm
23 x 30 mm
786-527 25 x 26 mm
28 x 38 mm
786-528 28 x 29 mm
33 x 45 mm

29 mm
26 mm
22 mm

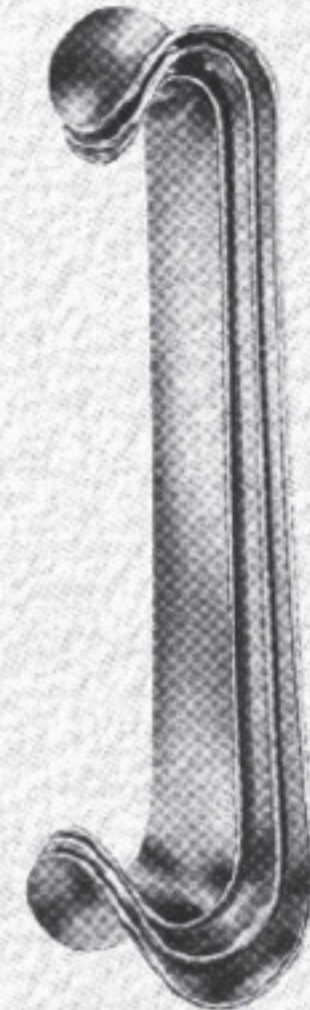

28 mm
38 mm
45 mm

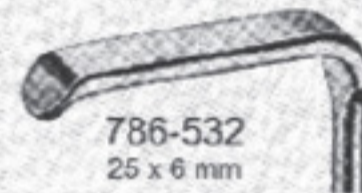

786-532
25 x 6 mm



786-533
35 x 8 mm

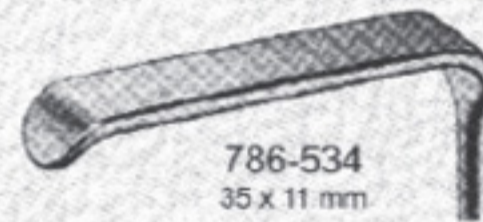

786-534
35 x 11 mm

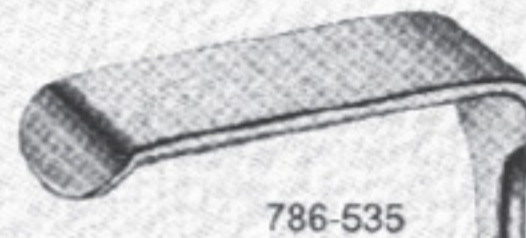

786-535
35 x 15 mm

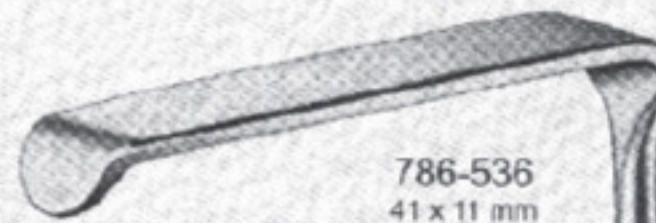

786-536
41 x 11 mm



786-537
55 x 11 mm



786-532
Kocher-Langenbeck
21,5 cm



Cheek Retractors

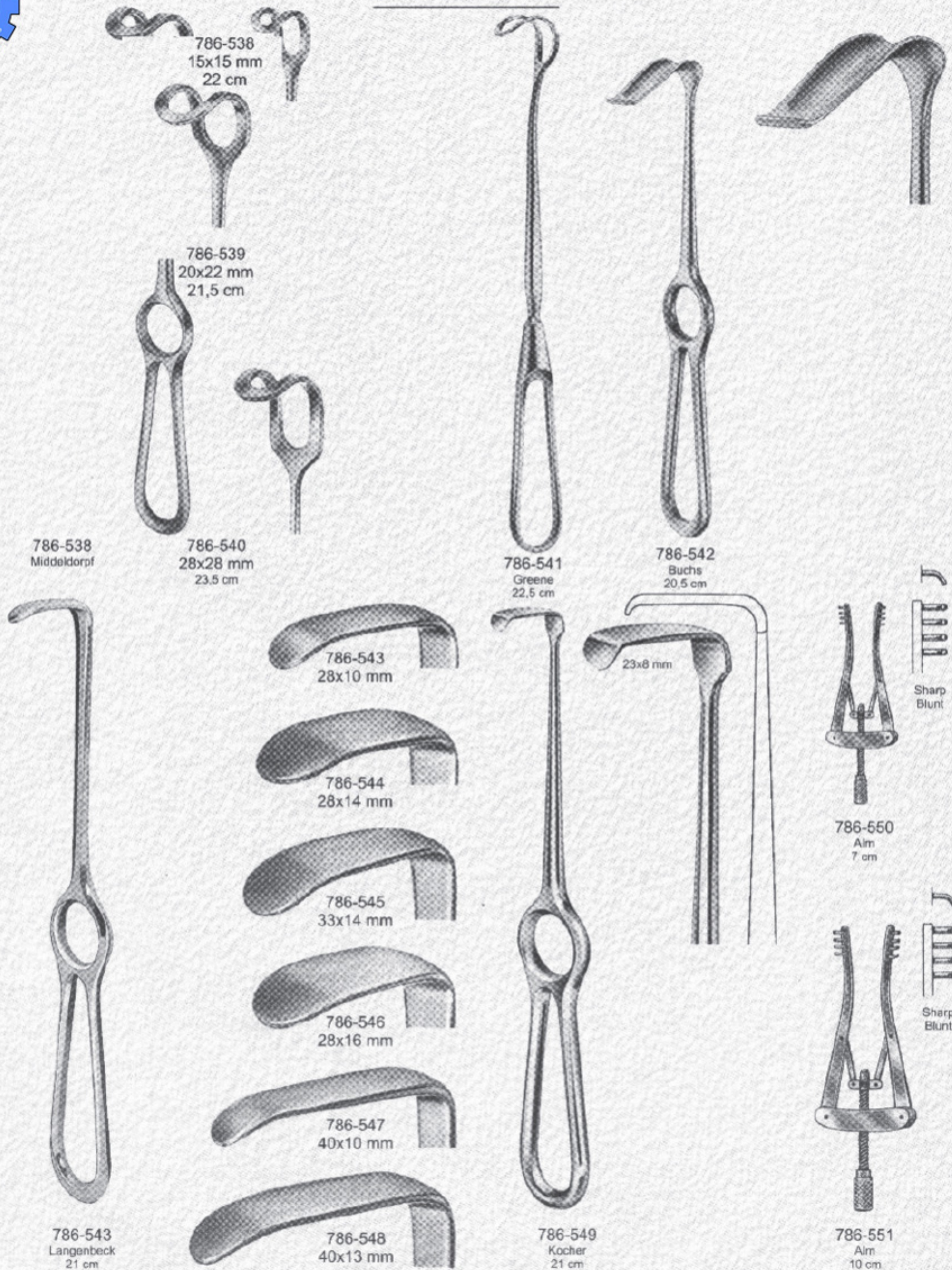



Elevators

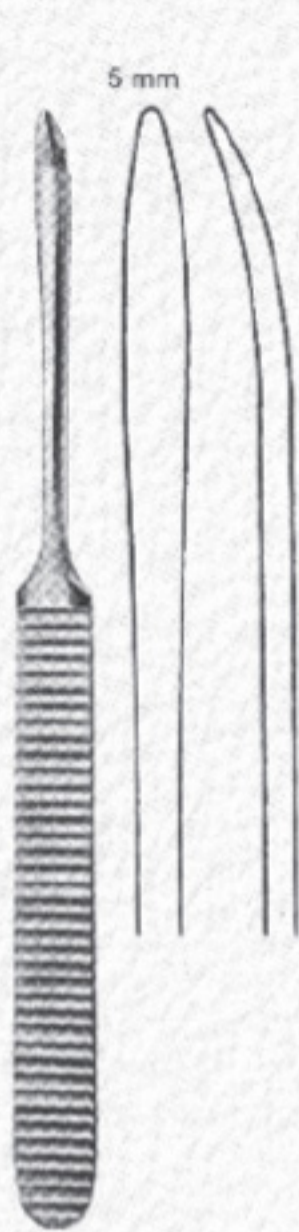

786-552
Williger
16,5 cm

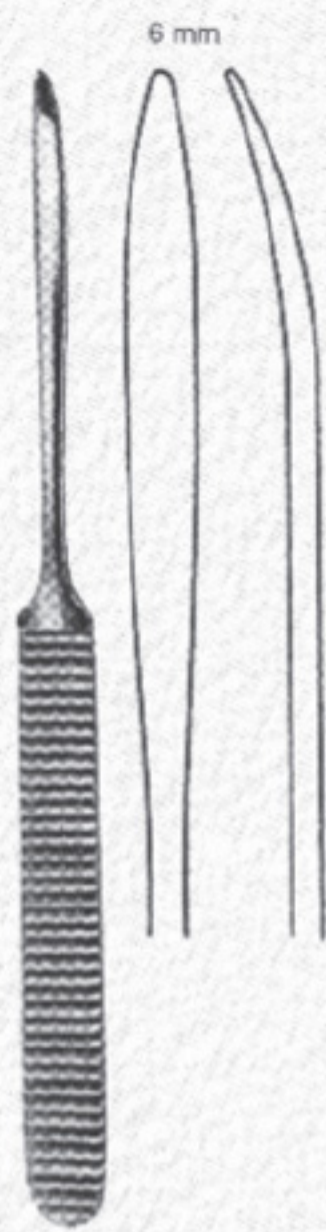

786-553
Williger
17 cm

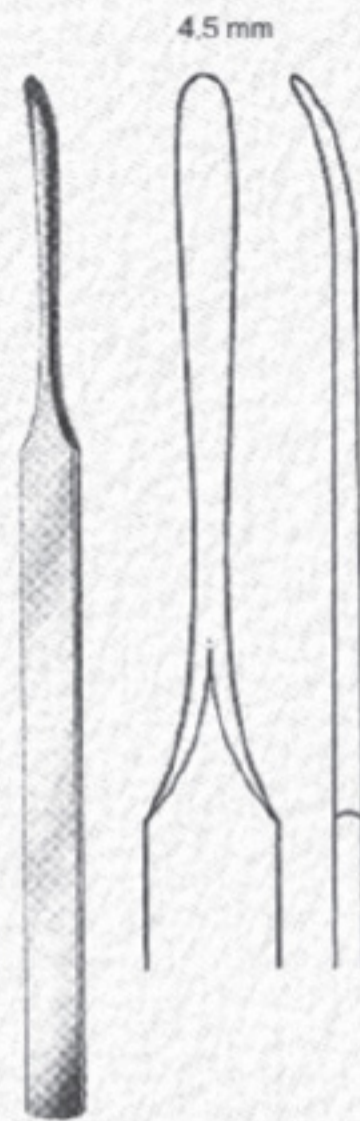

786-554
Konig
15,5 cm

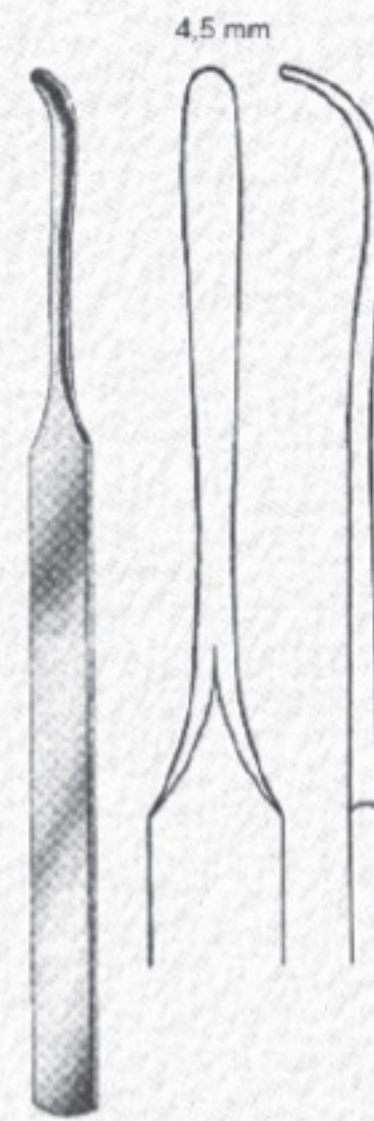

786-555
Konig
15,5 cm



786-556
Freer
19 cm



786-557
Freer
18,5 cm

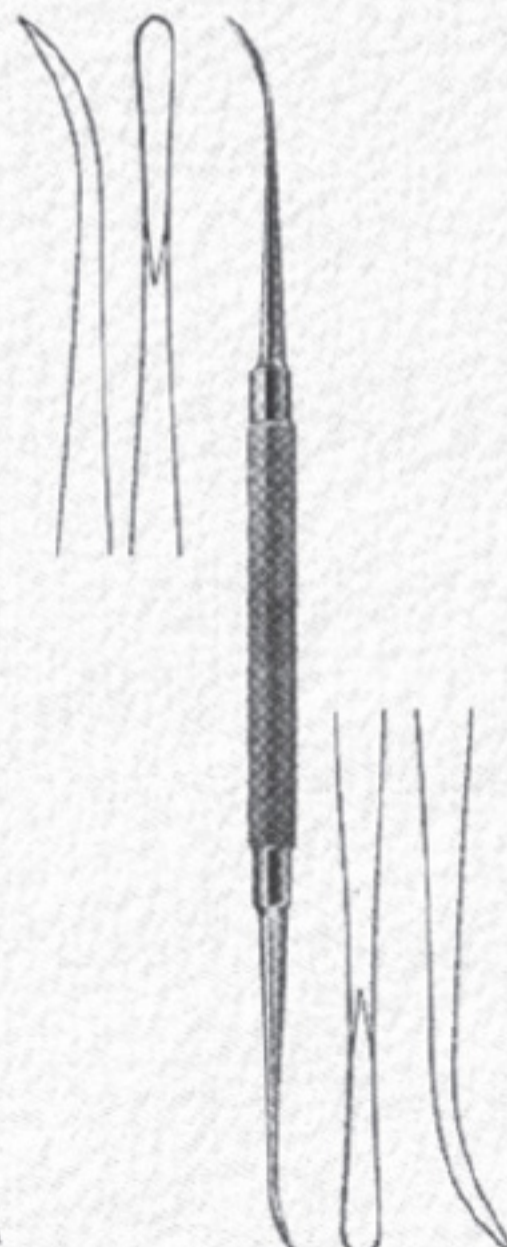

786-558
Freer-Yasargin
18,5 cm



786-559
Kendzia
17 cm



Raspatories

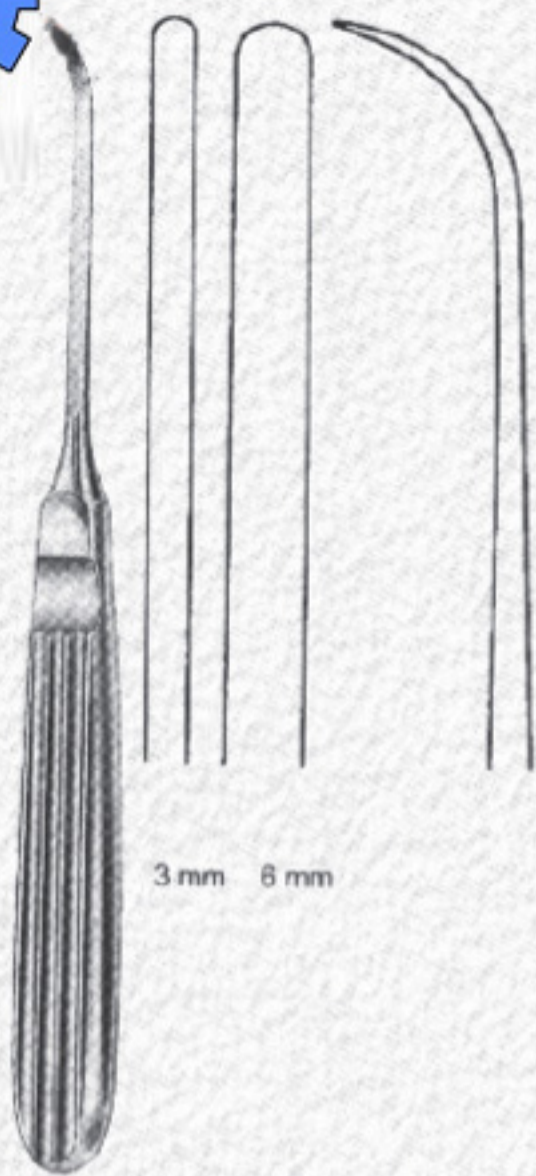

3 mm 6 mm

786-560 3 mm
786-561 6 mm
17 cm

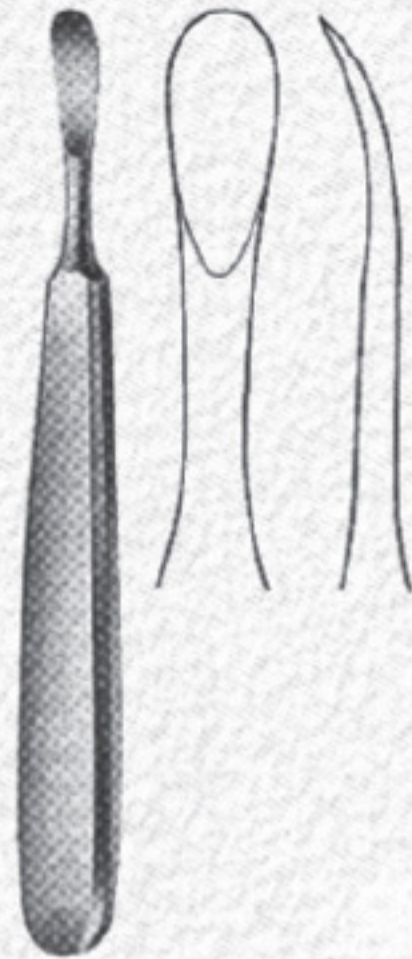

786-562 8 mm
Trelat
14 cm

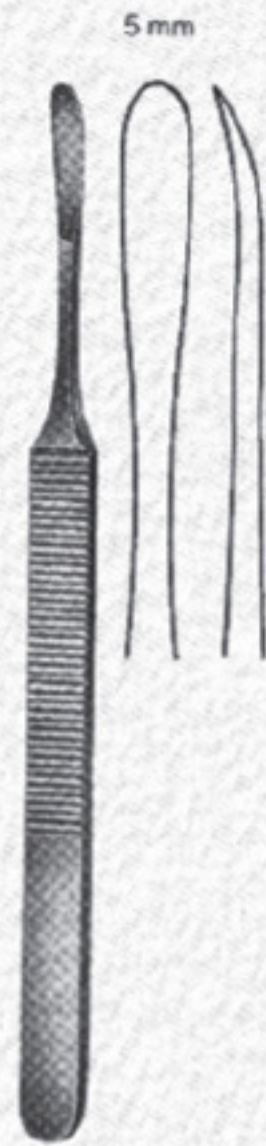

5 mm

786-563
Konig
15,5 cm

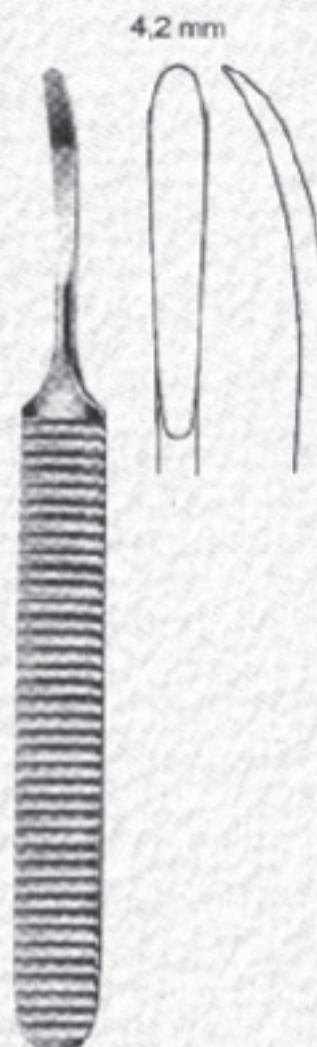

4,2 mm

786-564
Williger
14 cm

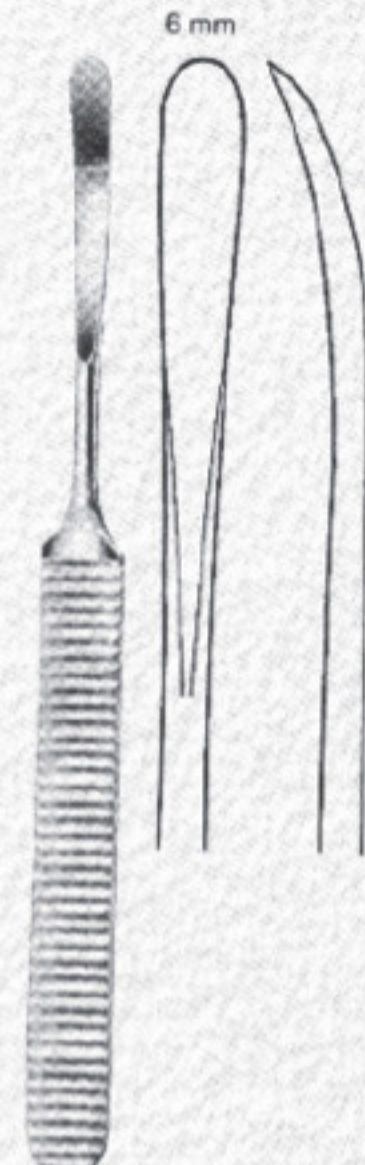

6 mm

786-565
Williger
16 cm

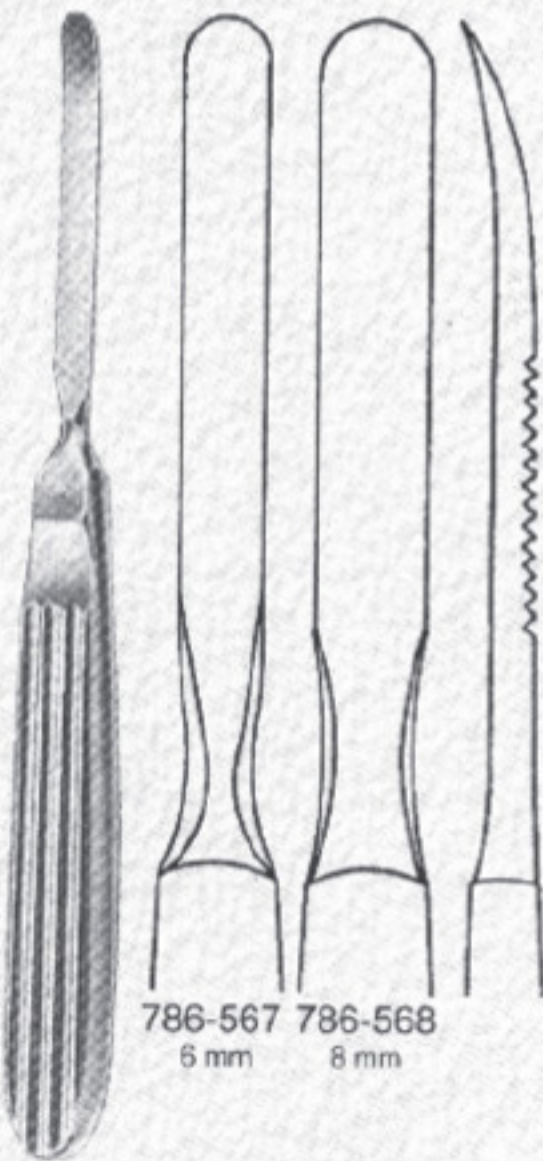

786-567 6 mm
786-568 8 mm

786-566 6 mm
16,5 cm

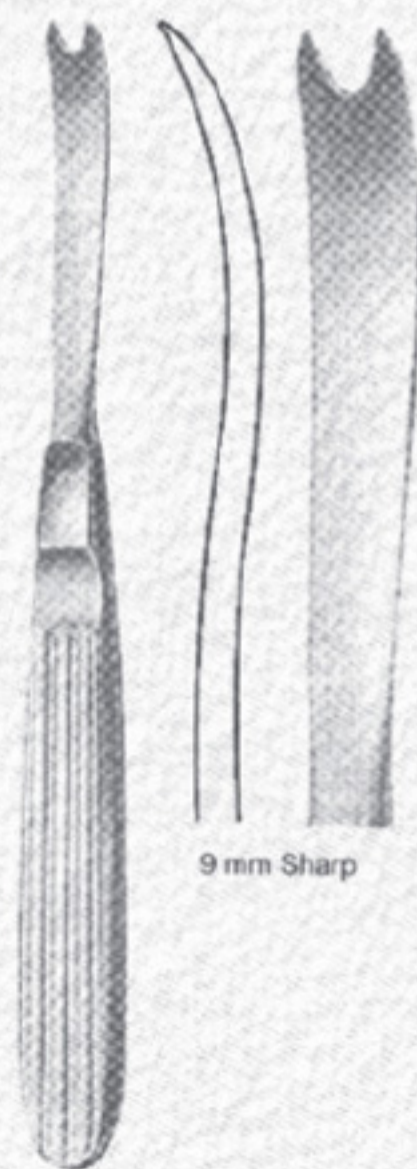

9 mm Sharp

786-569
Obwegeser
17 cm

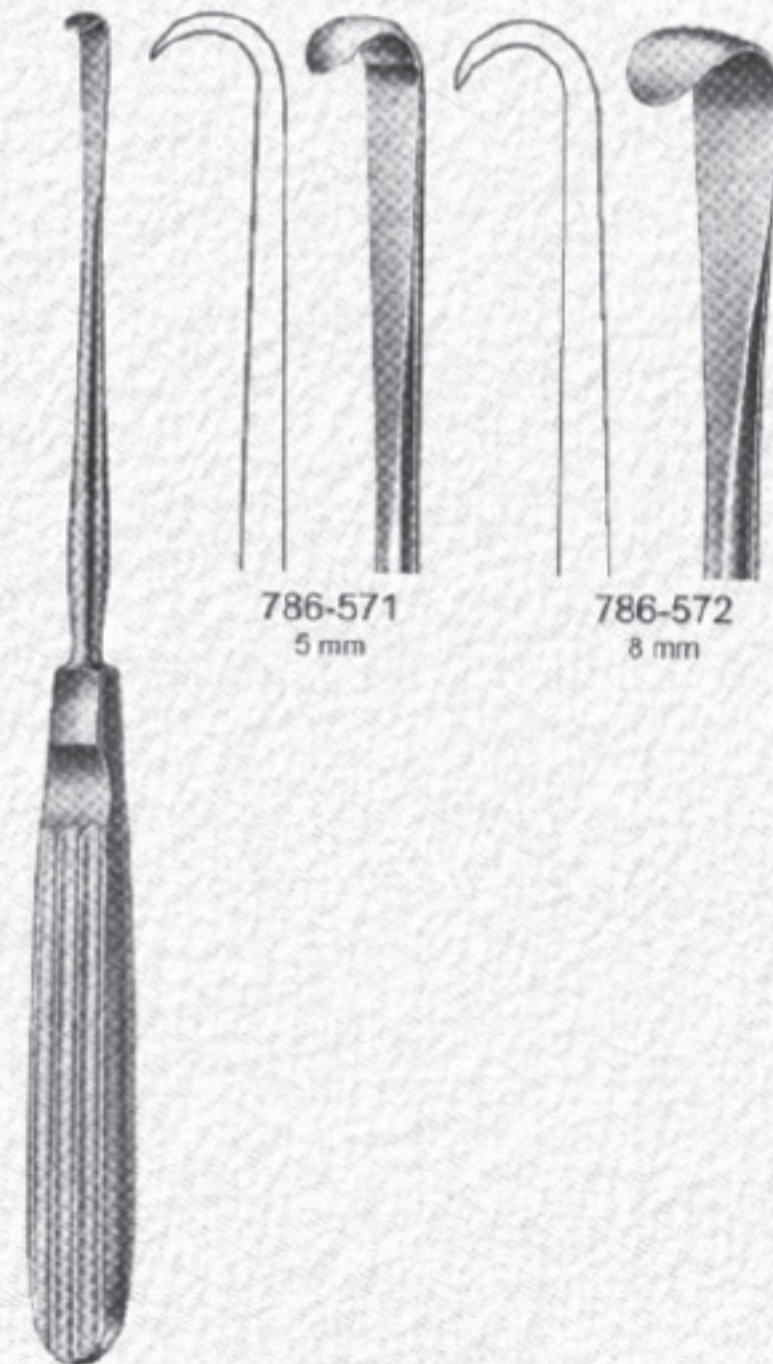

786-571
5 mm

786-572
8 mm

786-570
5 mm
20 cm

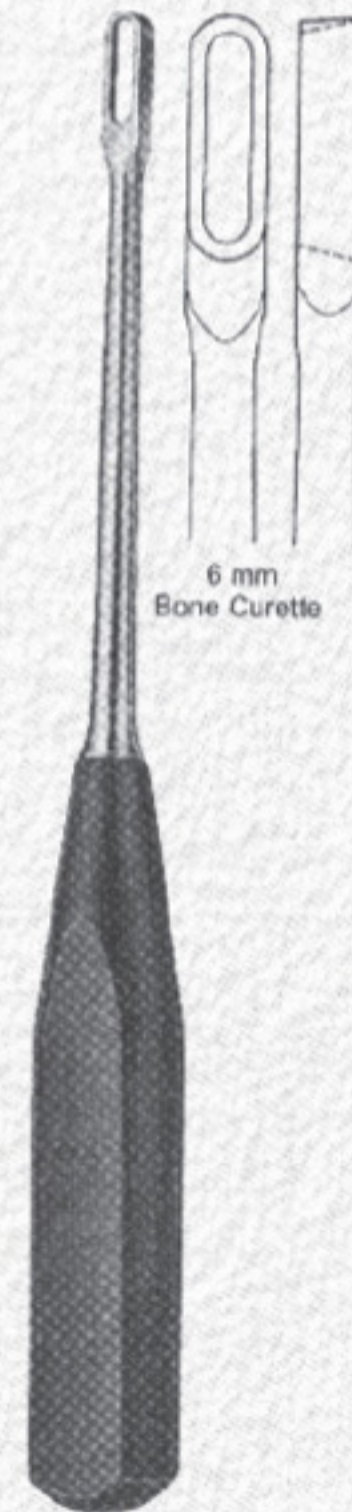

6 mm
Bone Curette

786-573
Tessier
22 cm



Elevators



786-574
Seldin
19,5 cm



786-575
Seldin
19,5 cm



786-576
Chompret
15 cm

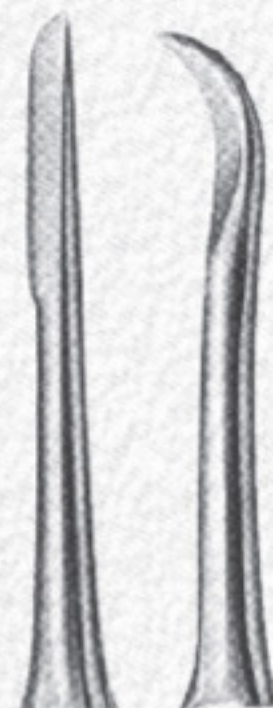

786-577 786-578

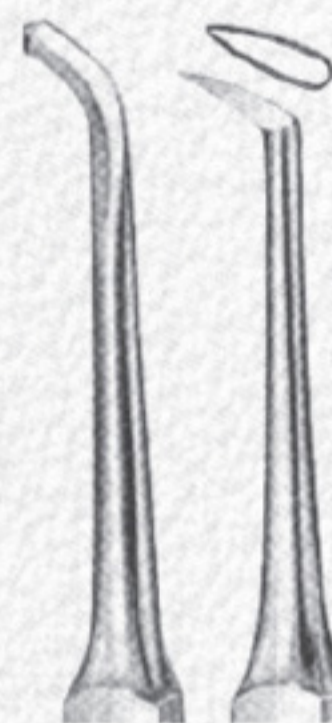

786-579 786-580

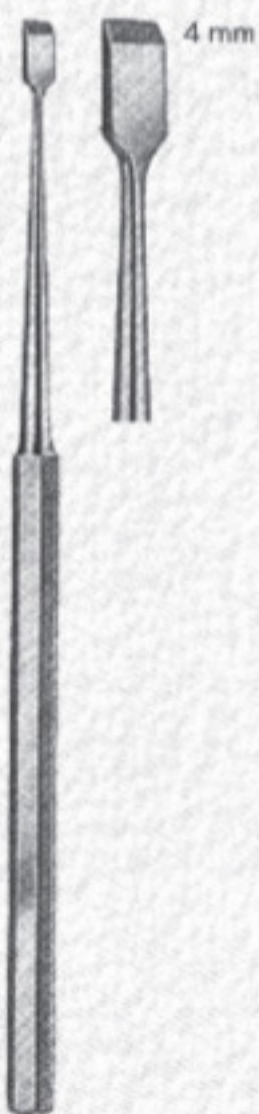

786-581
Freer
16 cm

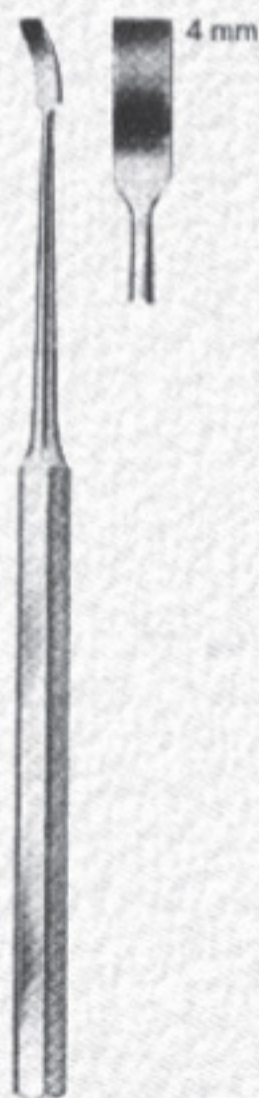

786-582
Freer
16 cm



786-583
Partsch, mod
14,5 cm



786-584
Mead
16,5 cm



786-585
Mead
18 cm



Chisels & Gouges

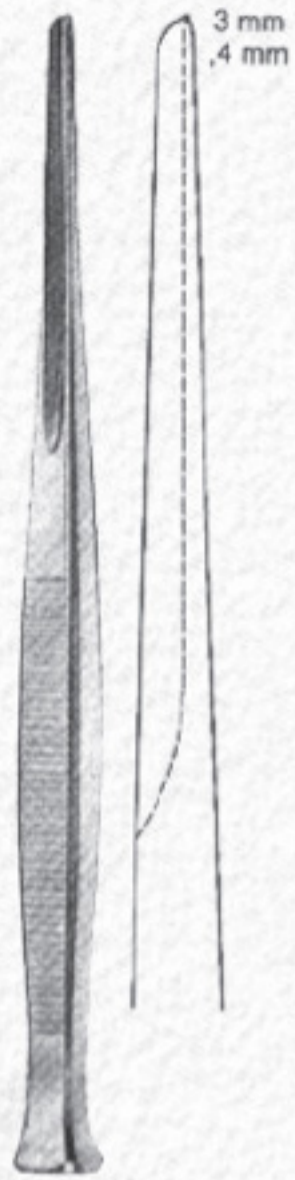

786-586
Partsch
17 cm



786-587
Freer
16 cm

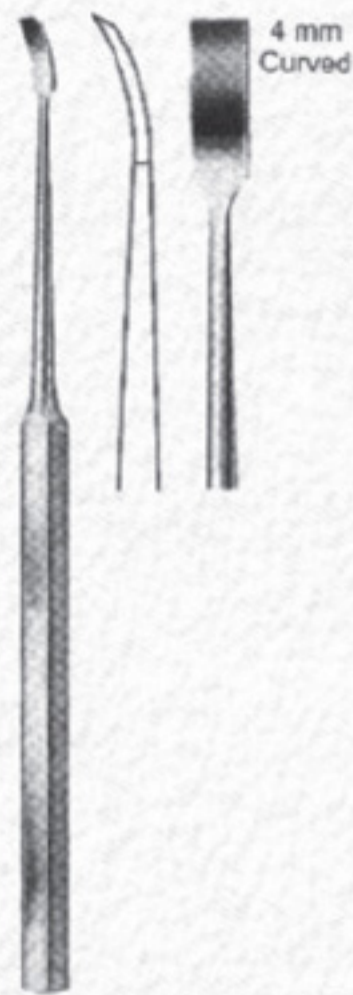

786-588
Freer
16 cm



786-589
Lucas
16 cm



786-590
Lucas
16 cm



786-591
Lambotte
12.5 cm



786-592
14 cm



786-593
Partsch
14 cm

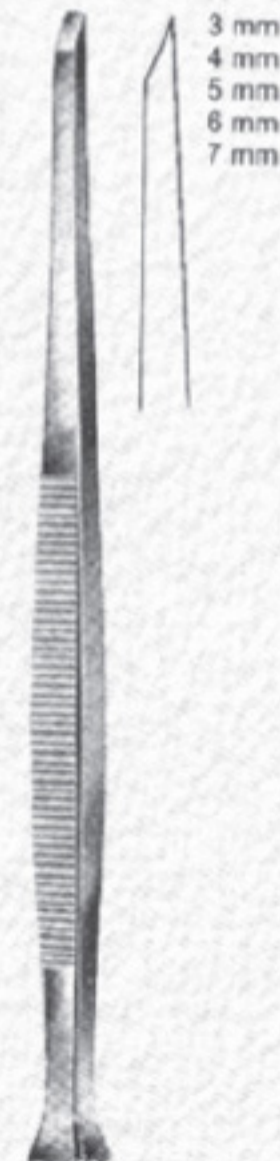

786-594
Partsch
17 cm

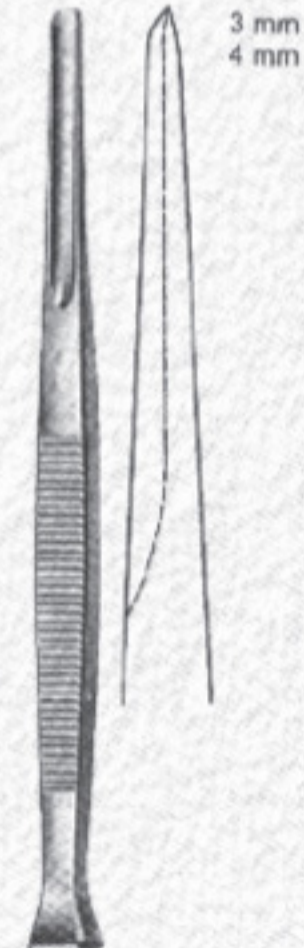

786-595
Partsch
14 cm



Rubber Dam Instruments

Clamp forceps



786-596
Ivory lightweight
17 cm

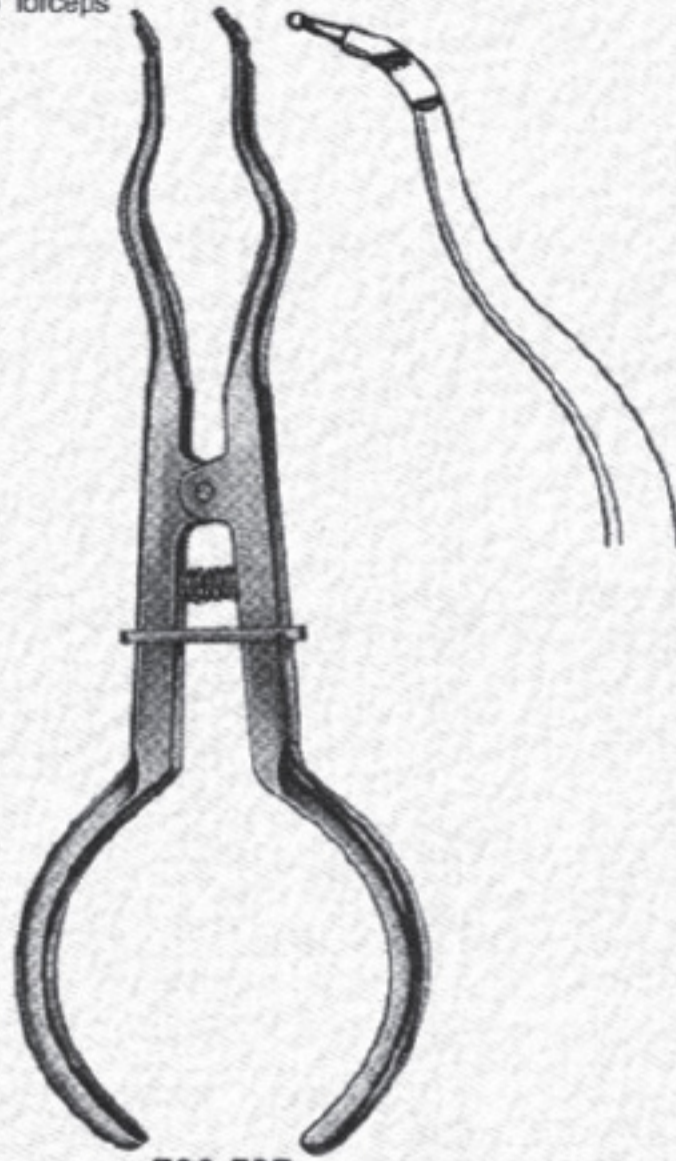

786-597
Brewer
17.5 cm

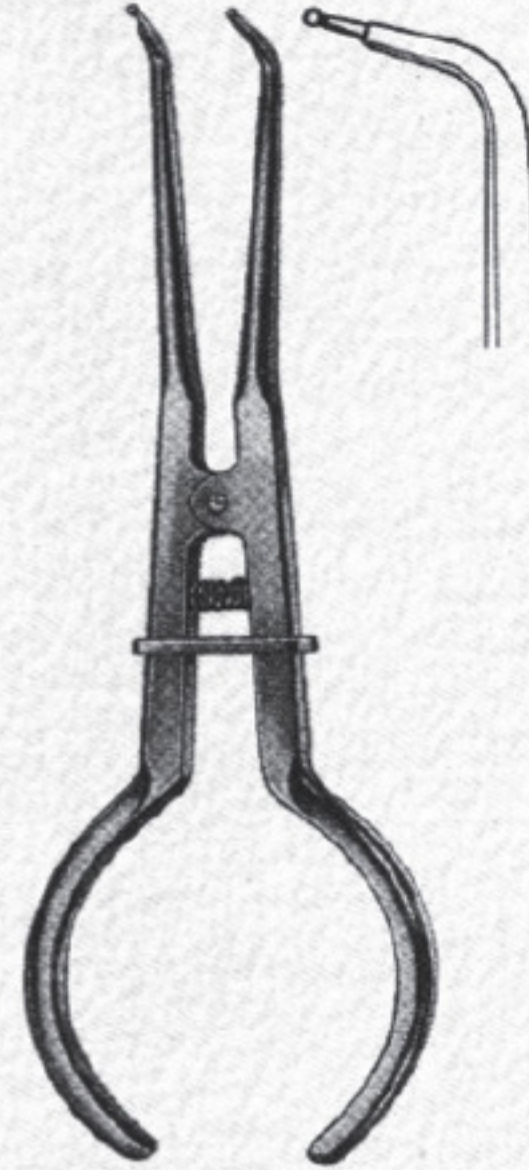

786-598
Stoke
17.5 cm

Punch forceps

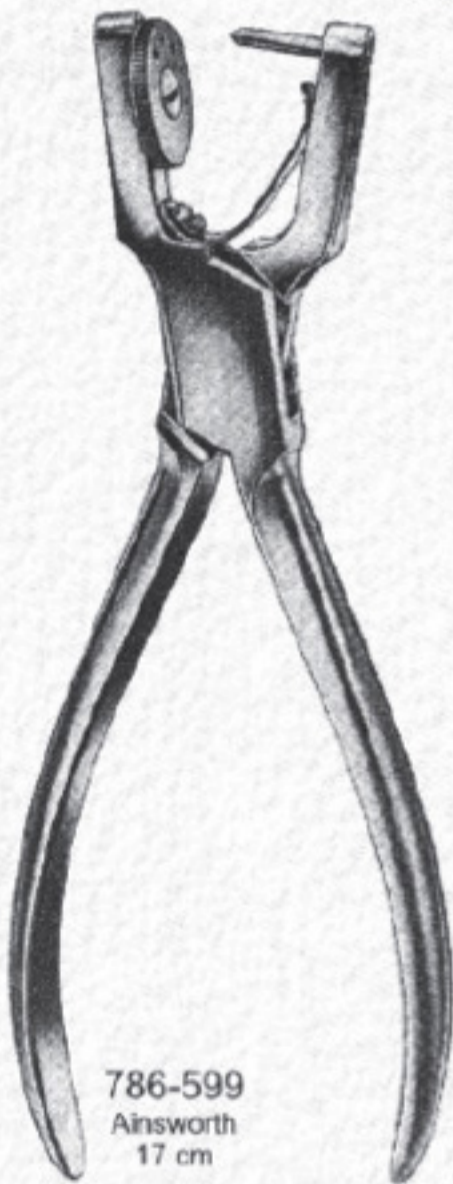

786-599
Ainsworth
17 cm

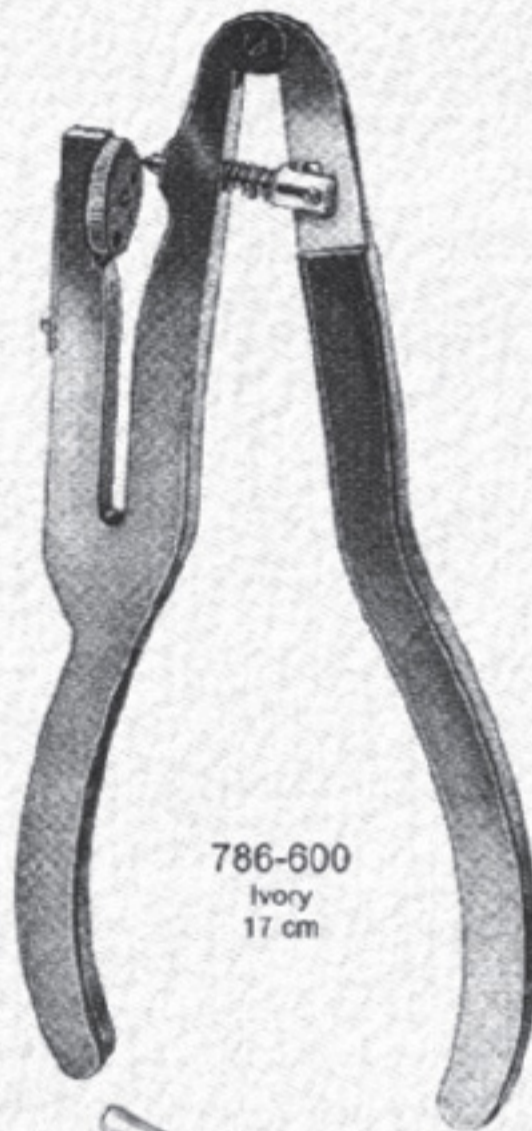

786-600
Ivory
17 cm

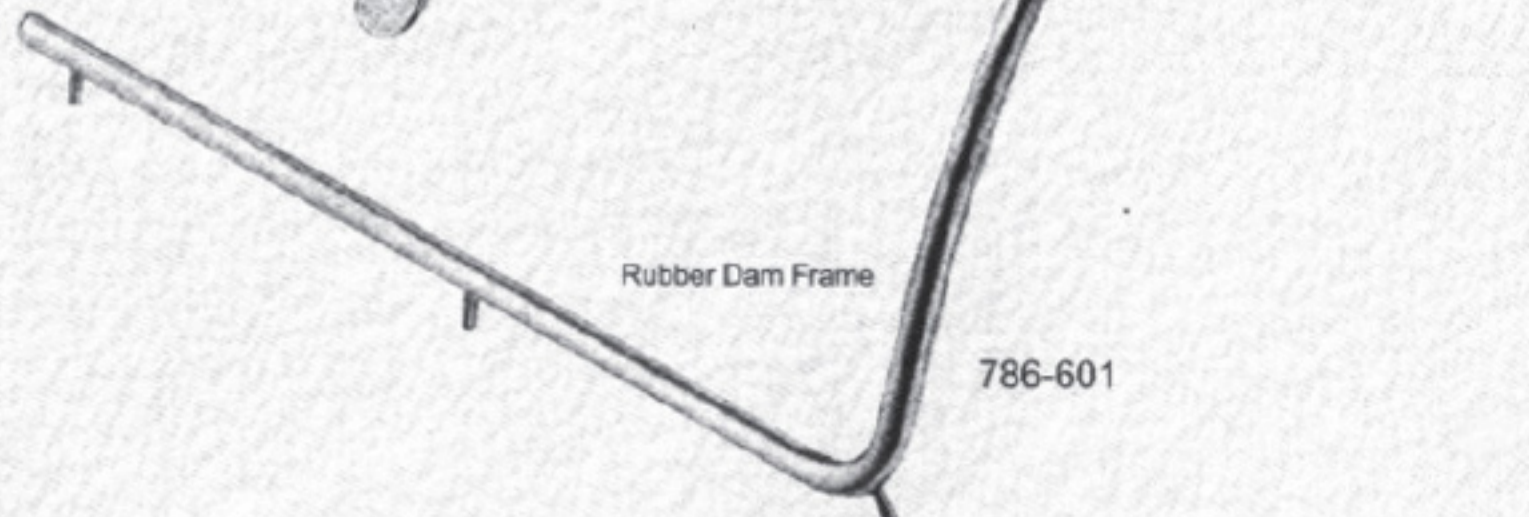

Rubber Dam Frame

786-601



Tissue Pliers

786-602
Fig.1
Adson
12 cm



786-603
Fig.1
Adson 1x2
12 cm

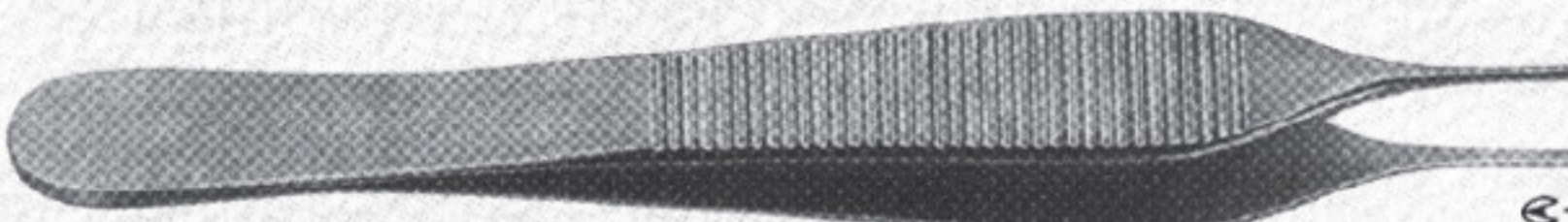

786-604
Fig.1
Semken-Taylor
12,5 cm



786-605
Fig.2
Semken-Taylor
12,5 cm



786-606
Fig.1
Semken-Taylor 1x2
12,5 cm



786-607
Fig.2
Semken-Taylor 1x2
12,5 cm

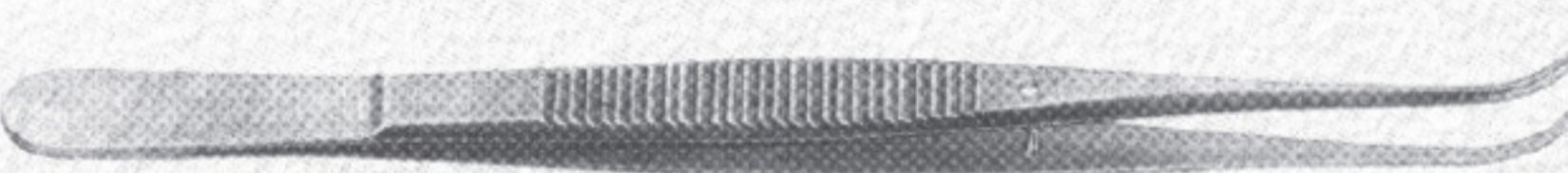

786-608
12 cm



786-609
11,5 cm



786-610
11,5 cm



786-611
11,5 cm

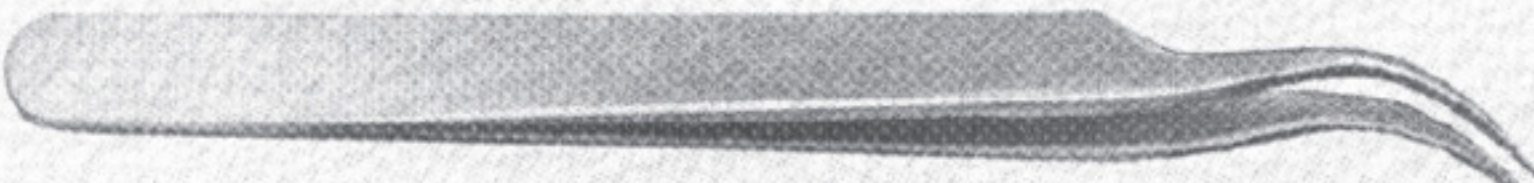



Cotton and Dressing Pliers

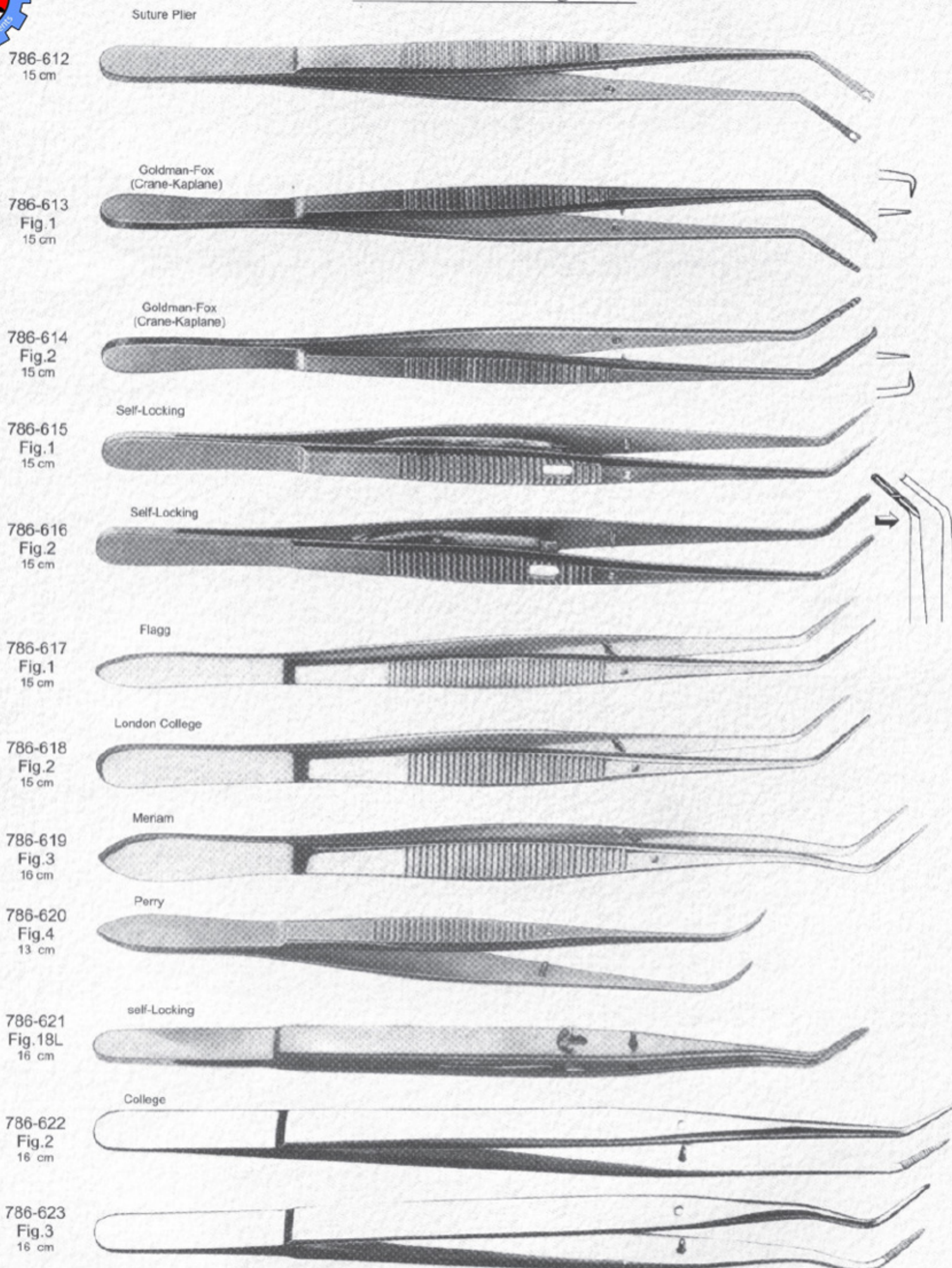



Mouth Mirrors

Handles For Mouth Mirrors

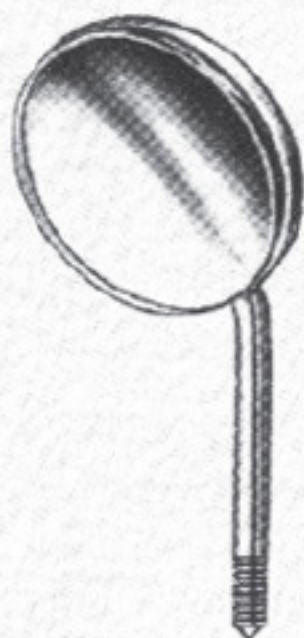

786-624
Plane 4
22 mm
Plane 5
24 mm



786-625
Magnifying 4
22 mm
Magnifying 5
24 mm



786-626
Plane 4
22 mm
Plane 5
24 mm

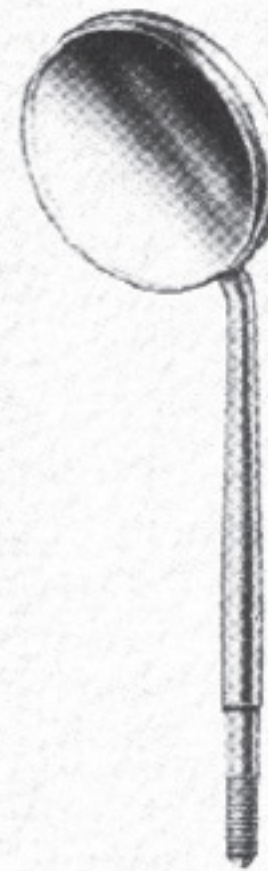

786-627
Magnifying 4
22 mm
Magnifying 5
24 mm
With cone-socket

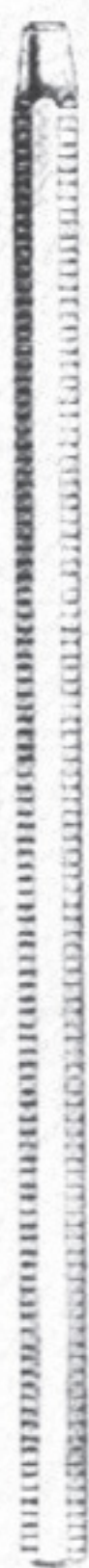

786-628



786-629
Hollow

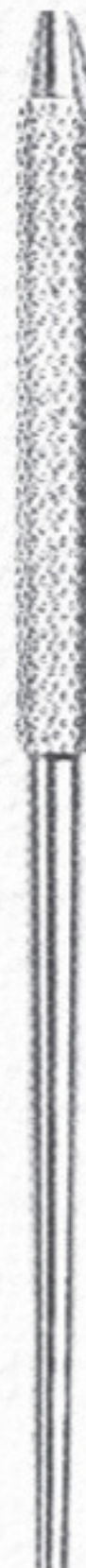

786-630



786-631
Hollow



Scalpel Handles



786-632
Fig. 3L



786-633
Fig. 7



786-634
Fig. 5

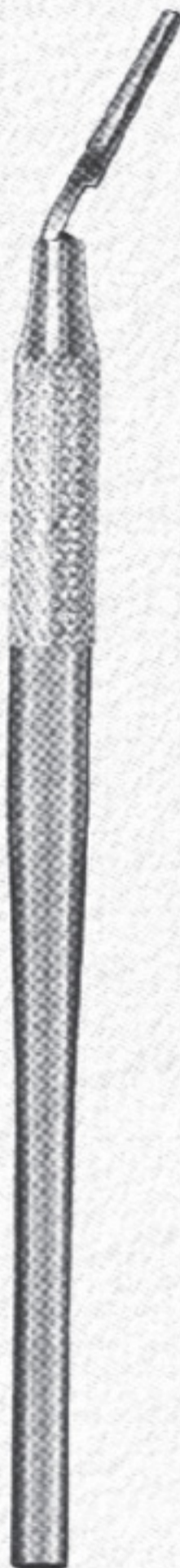

786-635
Fig. 5A



786-636
Fig. 3



786-637
Fig. 3G



786-638
Fig. 4



Handles Reference Guide



A
Single ended
knurling round



B
Double ended
knurling round



C
Single ended
octangle serrated

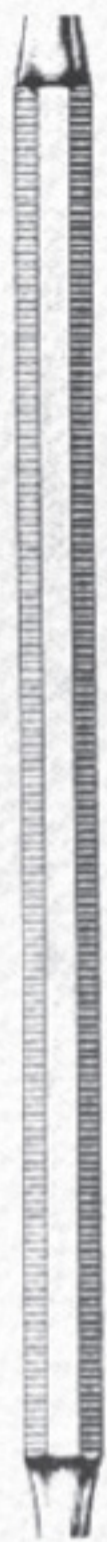

D
Double ended
octangle serrated



E
Single ended
hollow round



F
Double ended
hollow round



G
Double ended
hollow round grooved



H
Double ended
Swiss pattern octangle

Note:

If you have preference different from the standard handle shown, please specify the optional handle number when ordering. If the tip/handle combination you desire is not shown, we will be glad to provide you with a quote for its preparation.



Explorers Endodontic Instruments



786-639
Fig.23



786-640
Fig.2



786-641
Fig.16



786-642
Fig.9



786-643
Fig.10



786-644
Fig.12



786-645
Fig.11



786-646
Fig.6



786-647
Fig.8



786-648
Fig.5



786-649
Fig.17



786-650
Fig.17A



786-651
Fig.3



786-652
Fig.3A



786-653
Fig.1
Spreader



786-654
Fig.2
Spreader



786-655
Fig.3
Spreader



786-656
Fig.4
Spreader



786-657
Fig.5
Spreader



786-658
Fig.6
Spreader



786-659
Fig.7
Spreader



Explorers Probes



786-677
Fig.UT 1/2
Cattoni



786-678
Fig.23/17



786-679
Fig.23/17A



786-680
Fig.2



786-681
Fig.2A



786-682
Fig.3



786-683
Fig.16/23



786-684
Fig.16/3



786-685
Fig.6/1



786-686
Fig.6/17



786-687
Fig.6/23



786-688
Fig.UT 1/2
Cattoni



786-689
Goldman-Fox/Williams



786-690
Fig.1 N
Nabers



786-691
Fig.2N
Nabers

Root canal explorers



Explorers

Endodontic Instruments

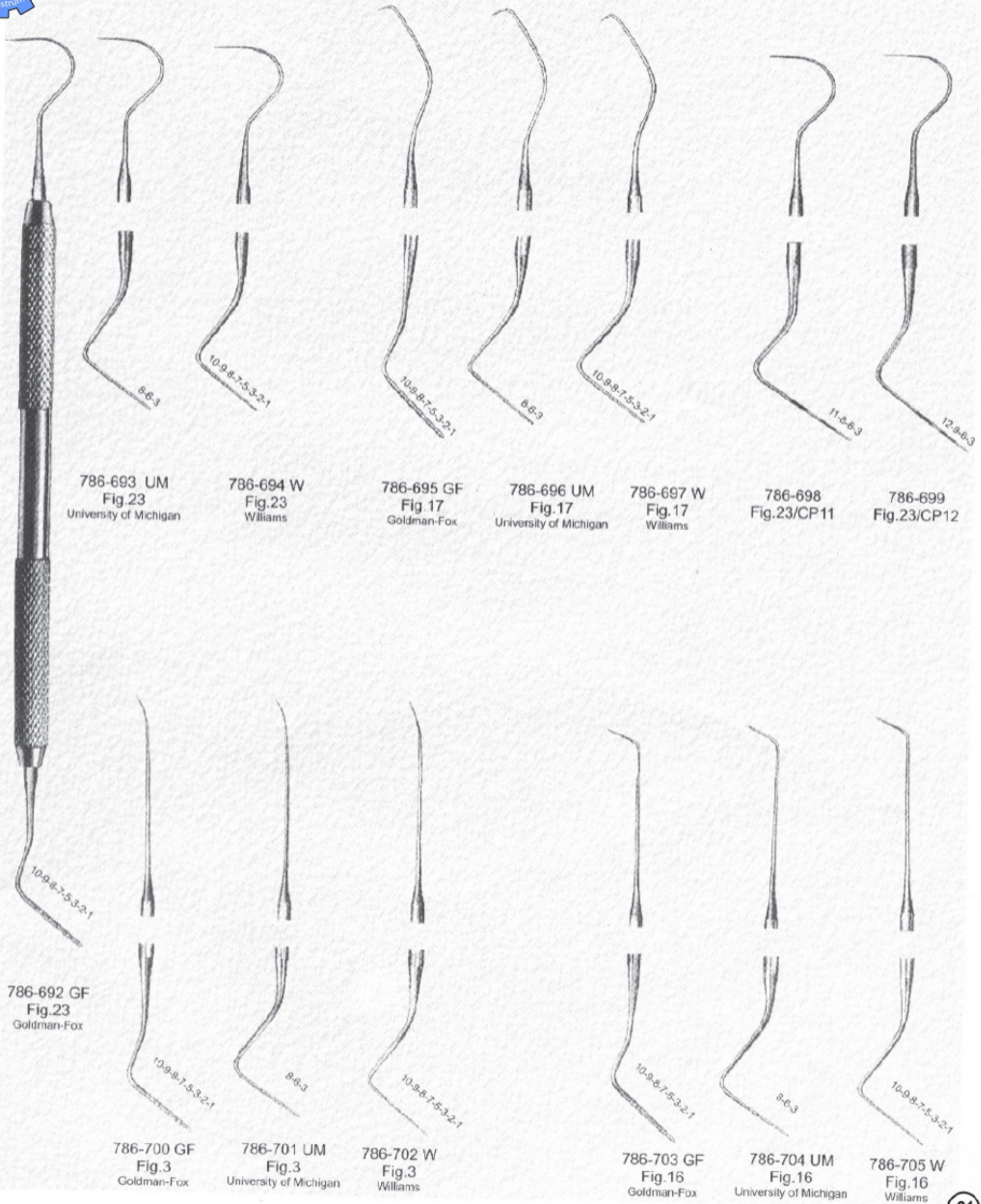



Filling Instruments

amalgam instruments

serrated

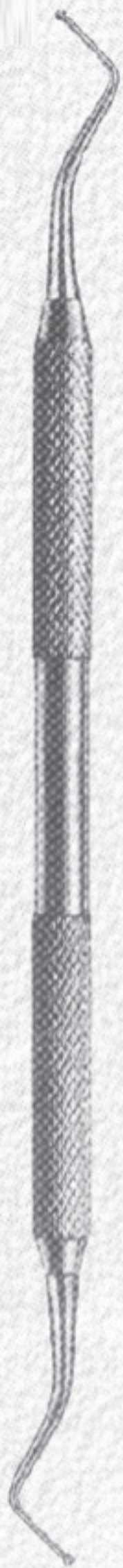

786-706
Fig.1



786-707
Fig.2



786-708
Fig.3



786-709
Fig.4



786-710
Fig.5



786-711
Fig.1



786-712
Fig.2



786-713
Fig.3



786-714
Fig.1L



786-715
Fig.2L



786-716
Fig.3L



786-717
Fig.1



786-718
Fig.2



786-719
Fig.3

smooth





amalgam instruments

Filling Instruments

serrated

smooth

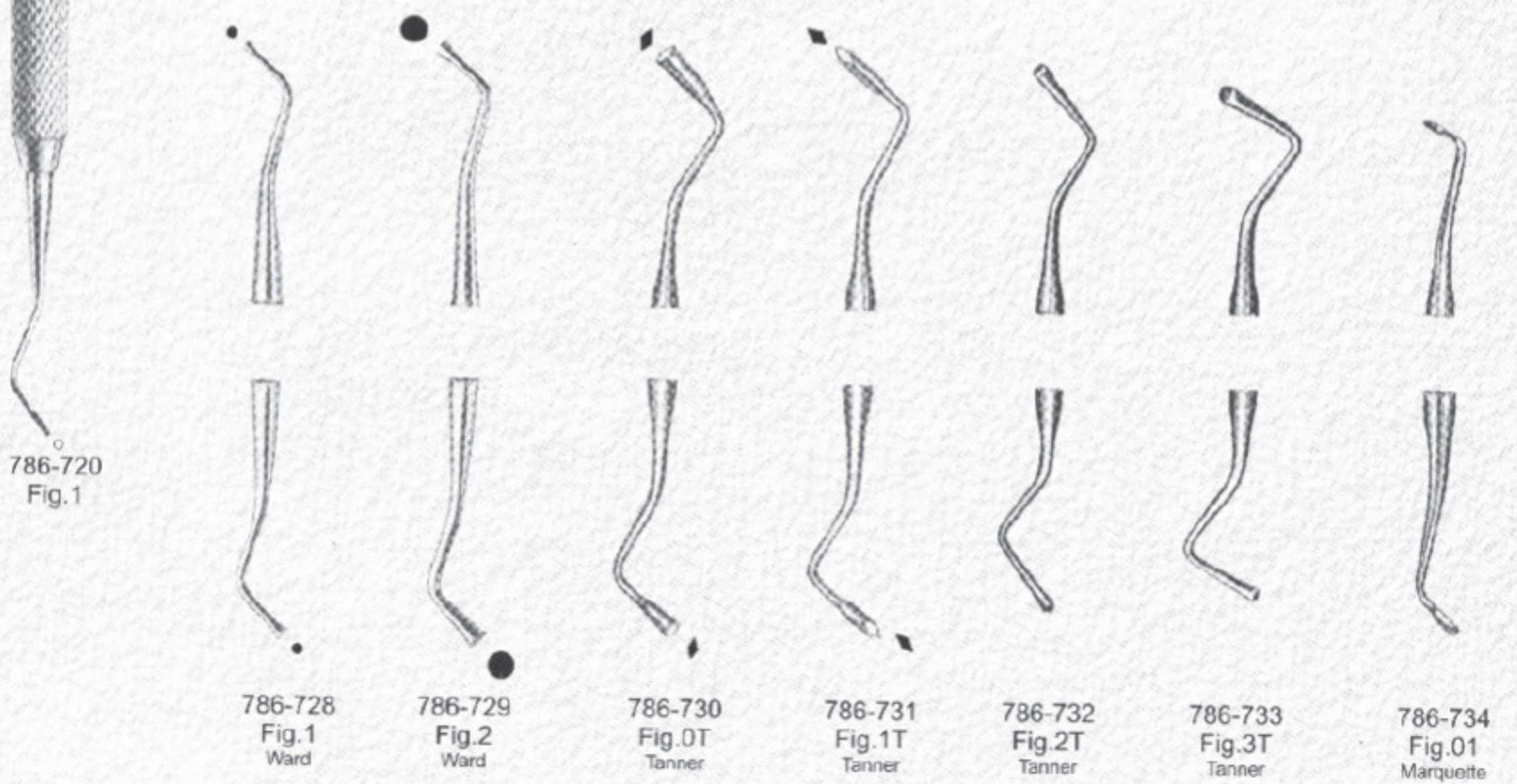
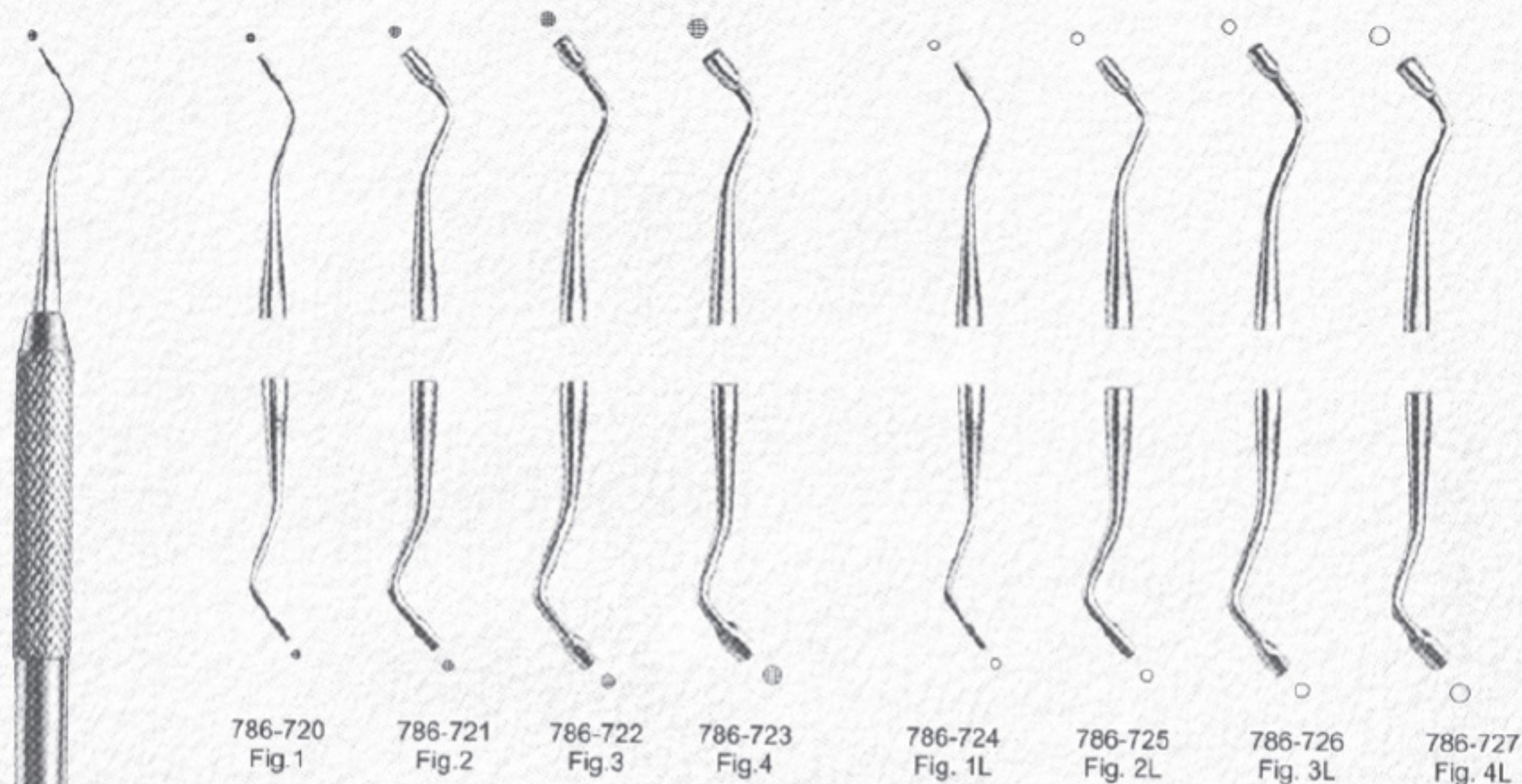

serrated



amalgam instruments

Filling Instruments

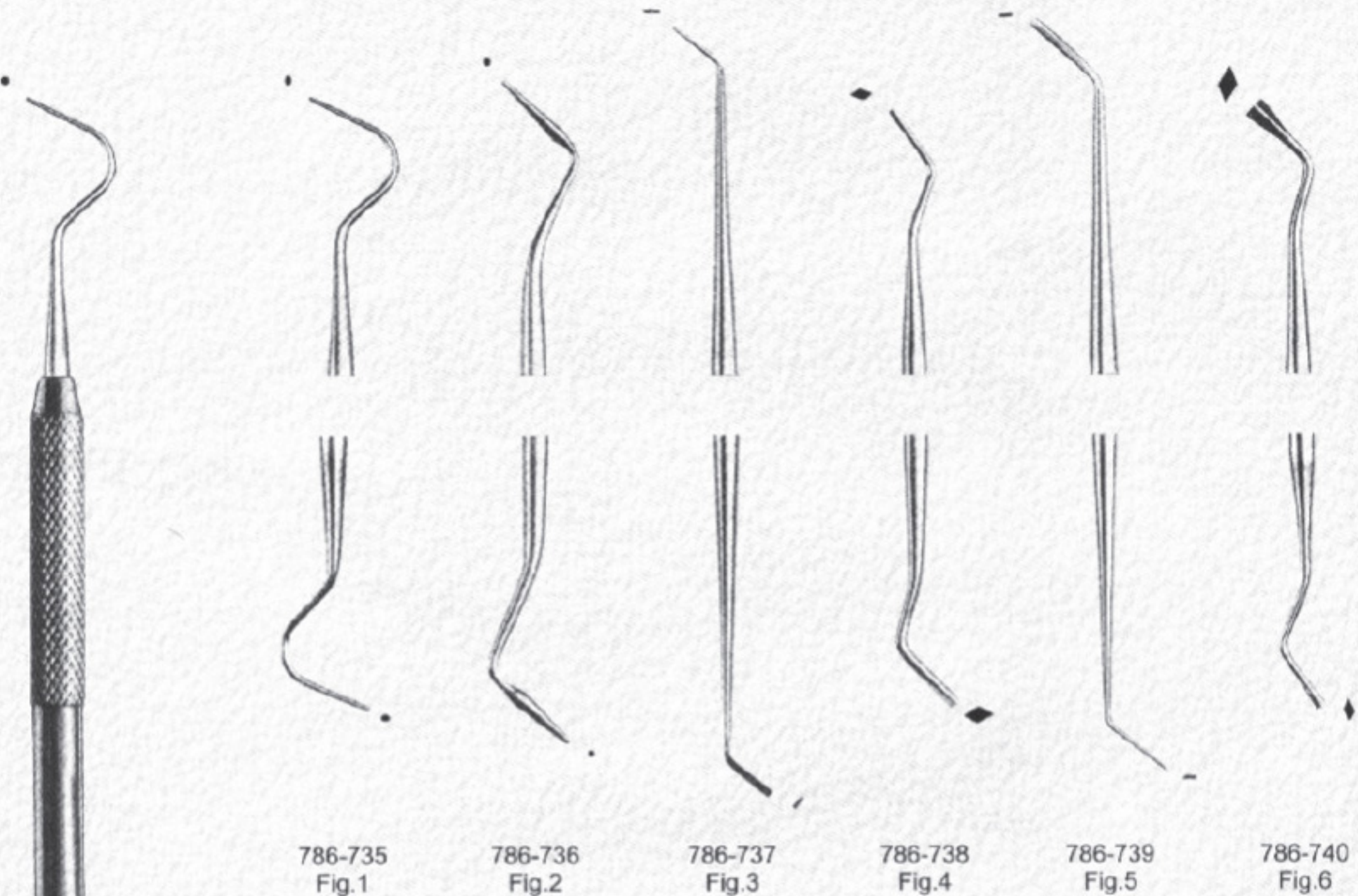

786-735
Fig.1

786-736
Fig.2

786-737
Fig.3

786-738
Fig.4

786-739
Fig.5

786-740
Fig.6

set of 6 pieces

786-735
Fig.1

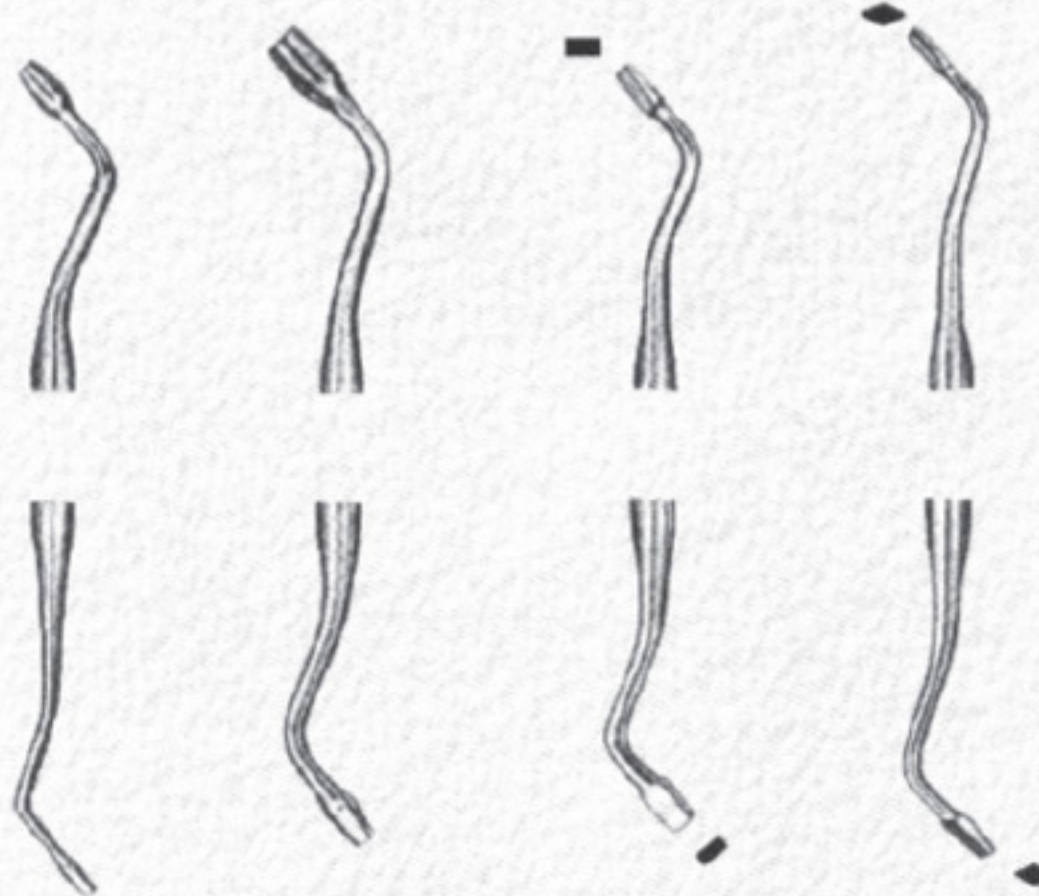

786-741
Fig. H1
Hollenback

786-742
Fig. H2
Hollenback

786-743
Fig. H3
Hollenback

786-744
Fig. H4
Hollenback



Burnishers

Filling Instruments

Plastic Filling Instruments

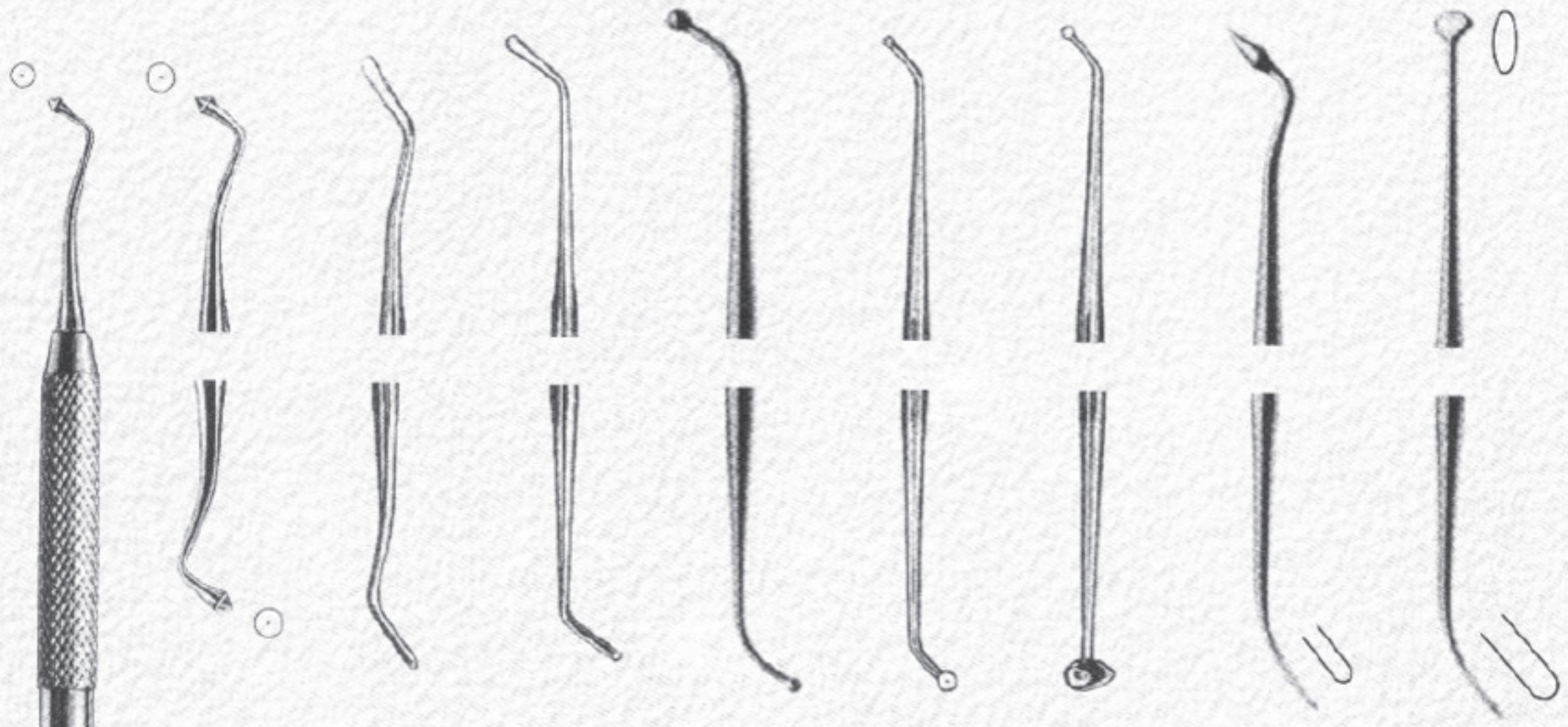

786-746
Fig. 2
Westcott

786-747
Fig. 2
Ladmore

786-748
Fig. 3
Ladmore

786-749
Fig. 18
Ball

786-750
Fig. 26-27S
Ball

786-751
Fig. 27-29
Ball

786-752
Fig. NYU/B2

786-753
Fig.2/31



786-745
Fig. 1
Westcott

plastic filling instruments

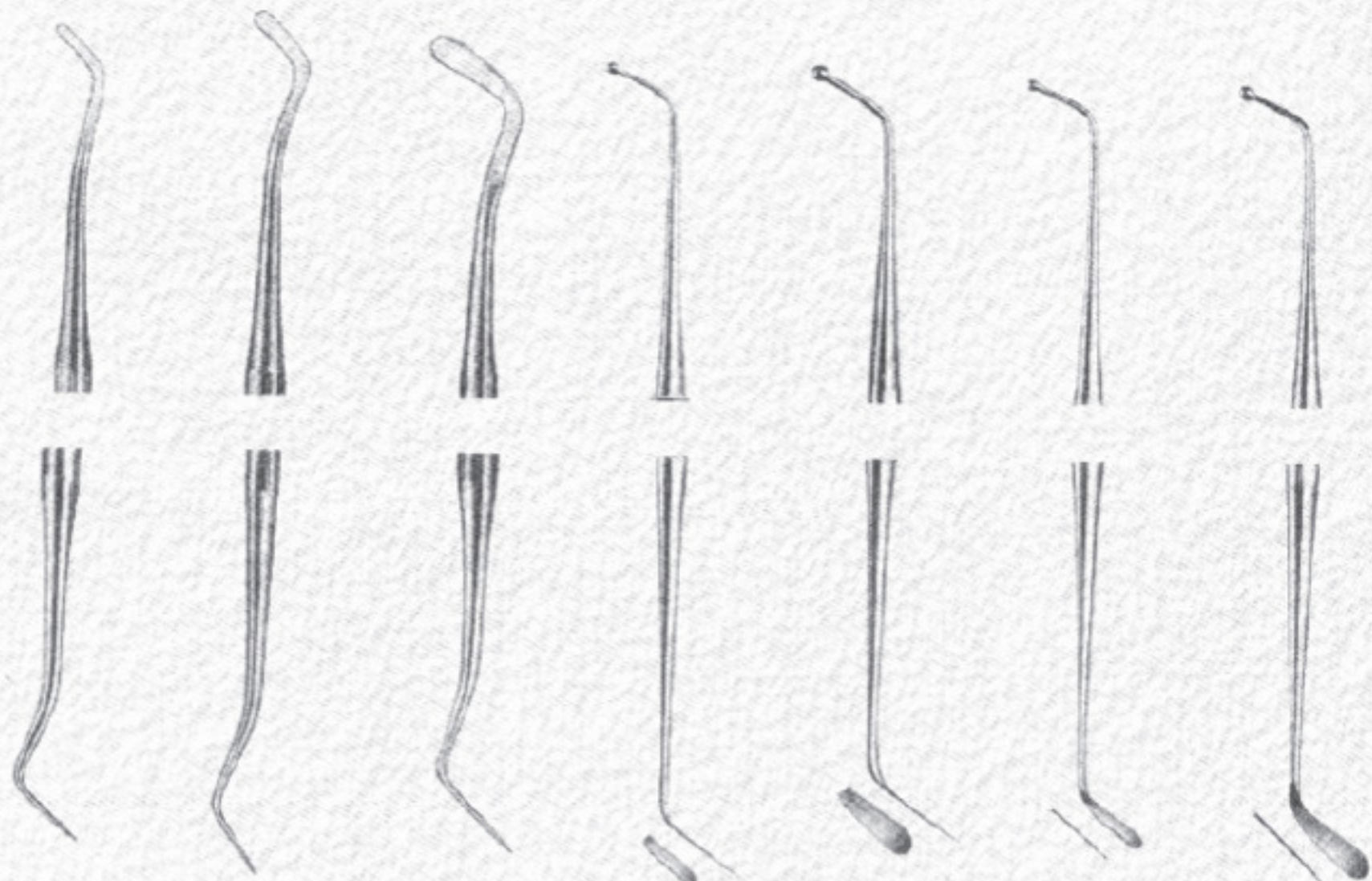

786-754
Fig.1

786-755
Fig.2

786-756
Fig.3

786-757
Fig.1

786-758
Fig.2

786-759
Fig.1

786-760
Fig.2



Plastic Filling Instruments Amalgam Carvers

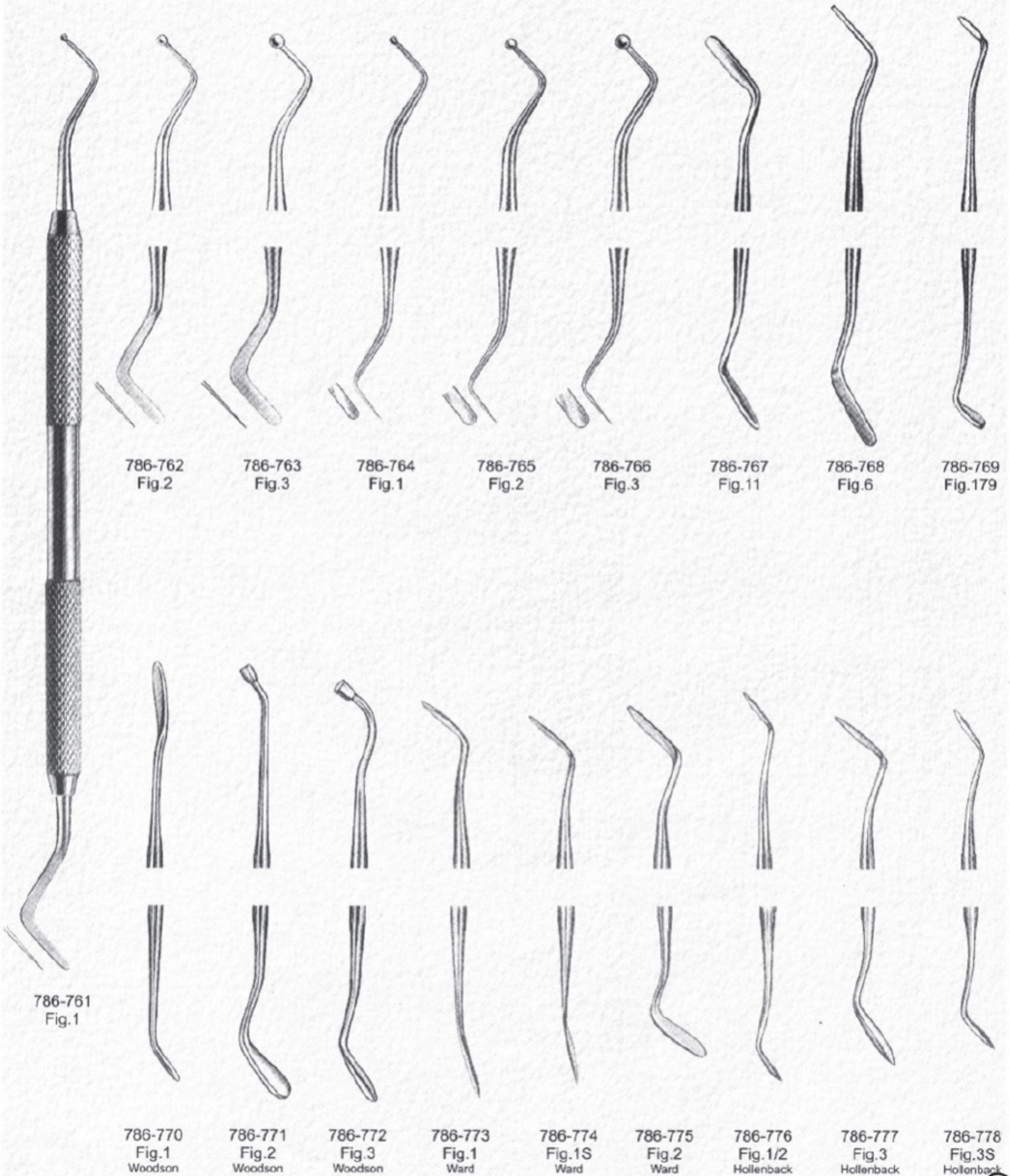



Amalgam Carvers Operative Instruments

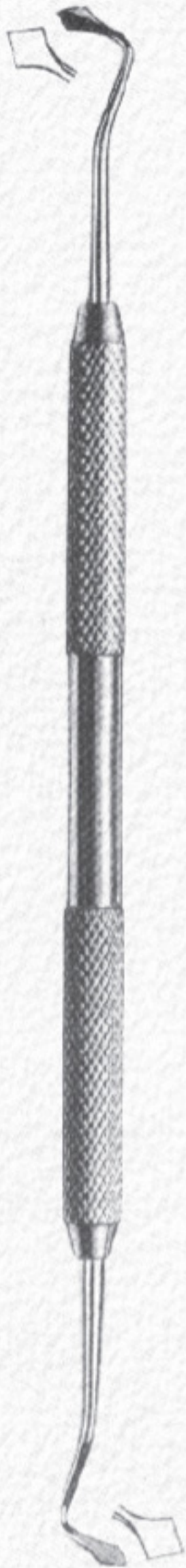

786-779
Fig.1
Farhm



786-780
Fig.2
USC



786-781
Fig.1
Interproximal



786-782
Fig.2
Interproximal
Off-Angle



786-783
Fig.SHO-A

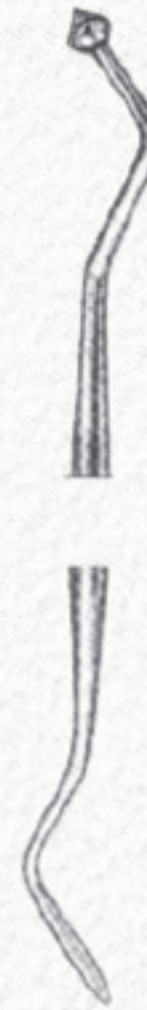

786-784
Fig.3-SHO

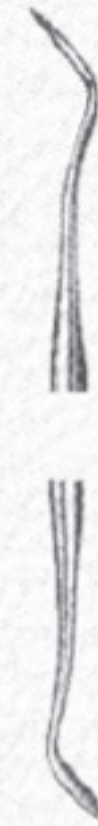

786-785
Fig.104



786-786
Fig.8
Wiland

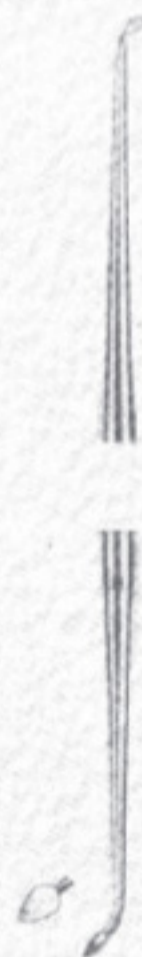

786-787
Fig.1



786-788
Fig.2



786-789
Fig.3



786-790
Fig.4



786-791

instrument for subgingival application
of tinctures and medicaments



786-792



786-793

cleoids-discoids



gingival margin trimmers

Cavity Preparation Instruments

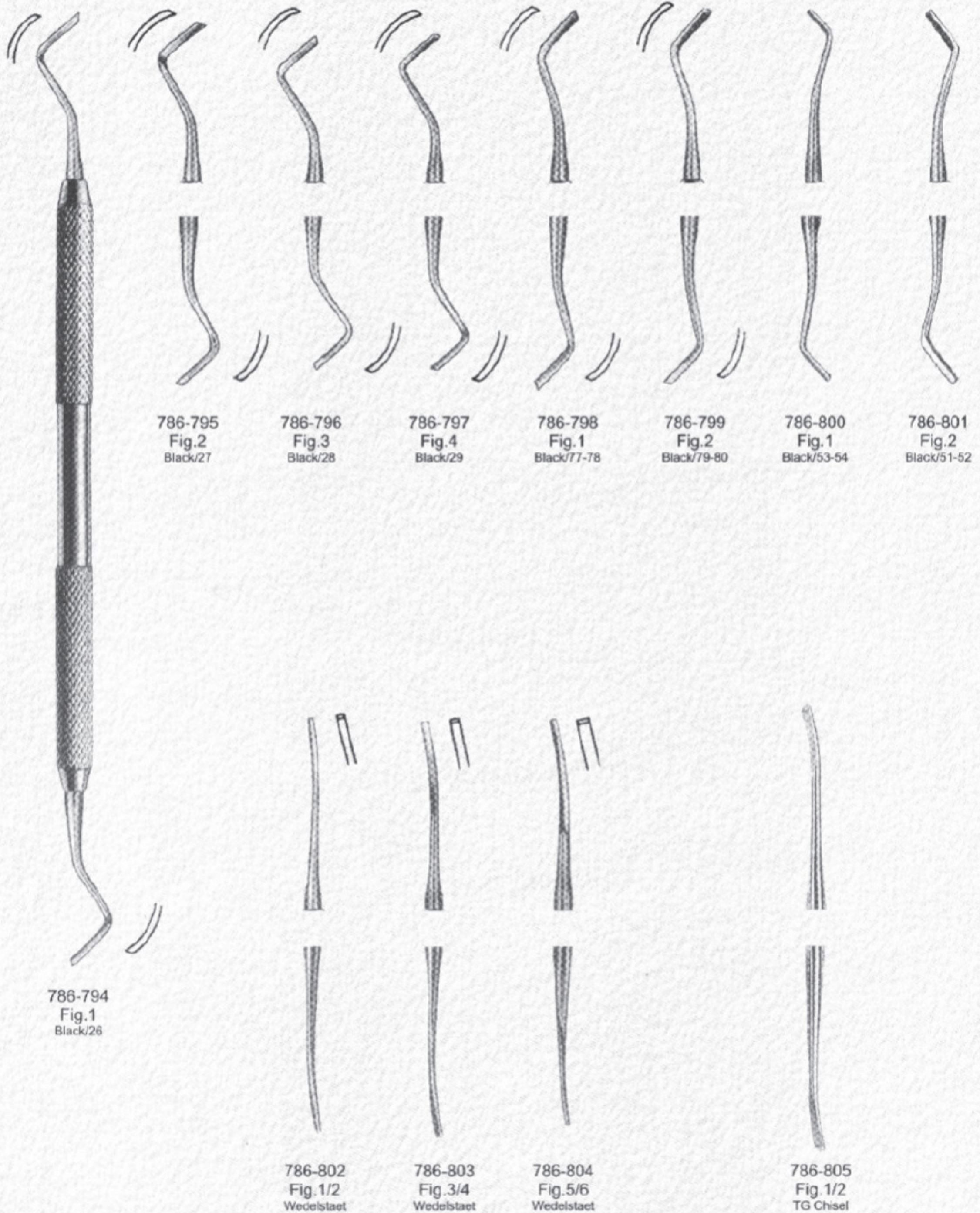



Excavators



786-806
Fig. 6

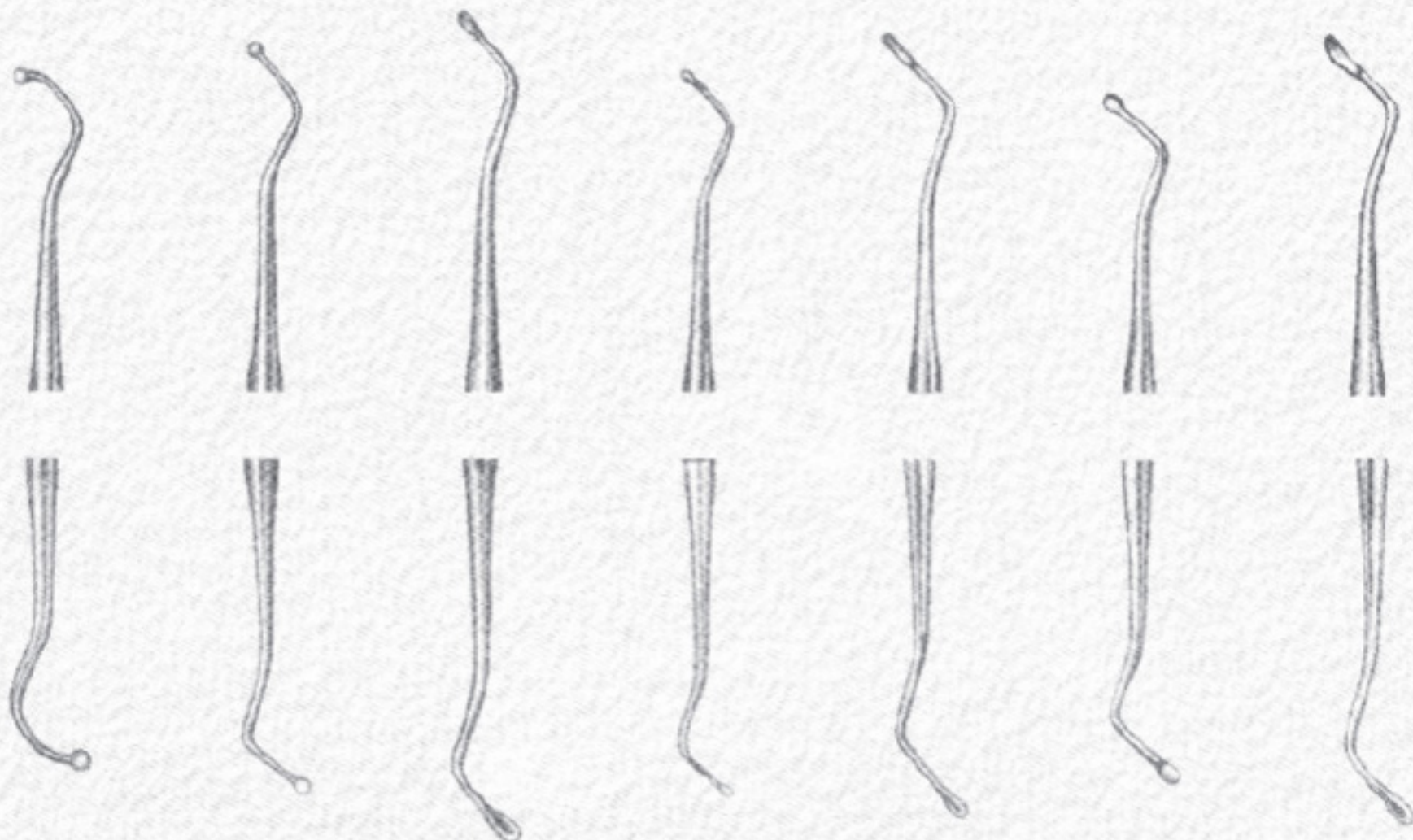

786-807
Fig. 14

786-808
Fig. 17

786-809
Fig. 17 W
Oval spoon

786-810
Fig. 18

786-811
Fig. 18 W
Oval spoon

786-812
Fig. 19

786-813
Fig. 19 W
Oval spoon

025-175S Set of 5

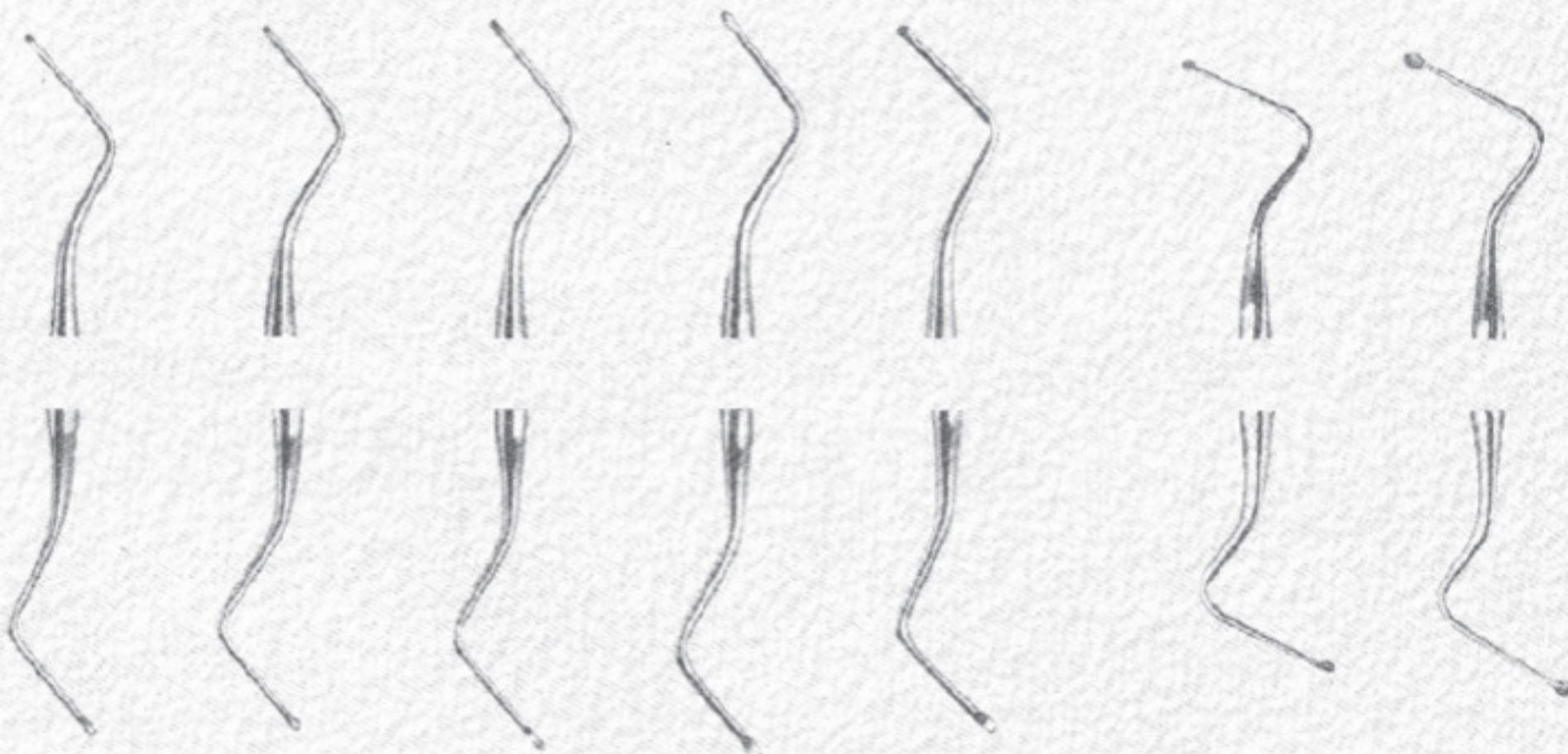

786-814
Fig. 0

786-815
Fig. 1

786-816
Fig. 2

786-817
Fig. 3

786-818
Fig. 4

786-819
Fig. 1

786-820
Fig. 2



Excavators



786-821
Fig. 38/39

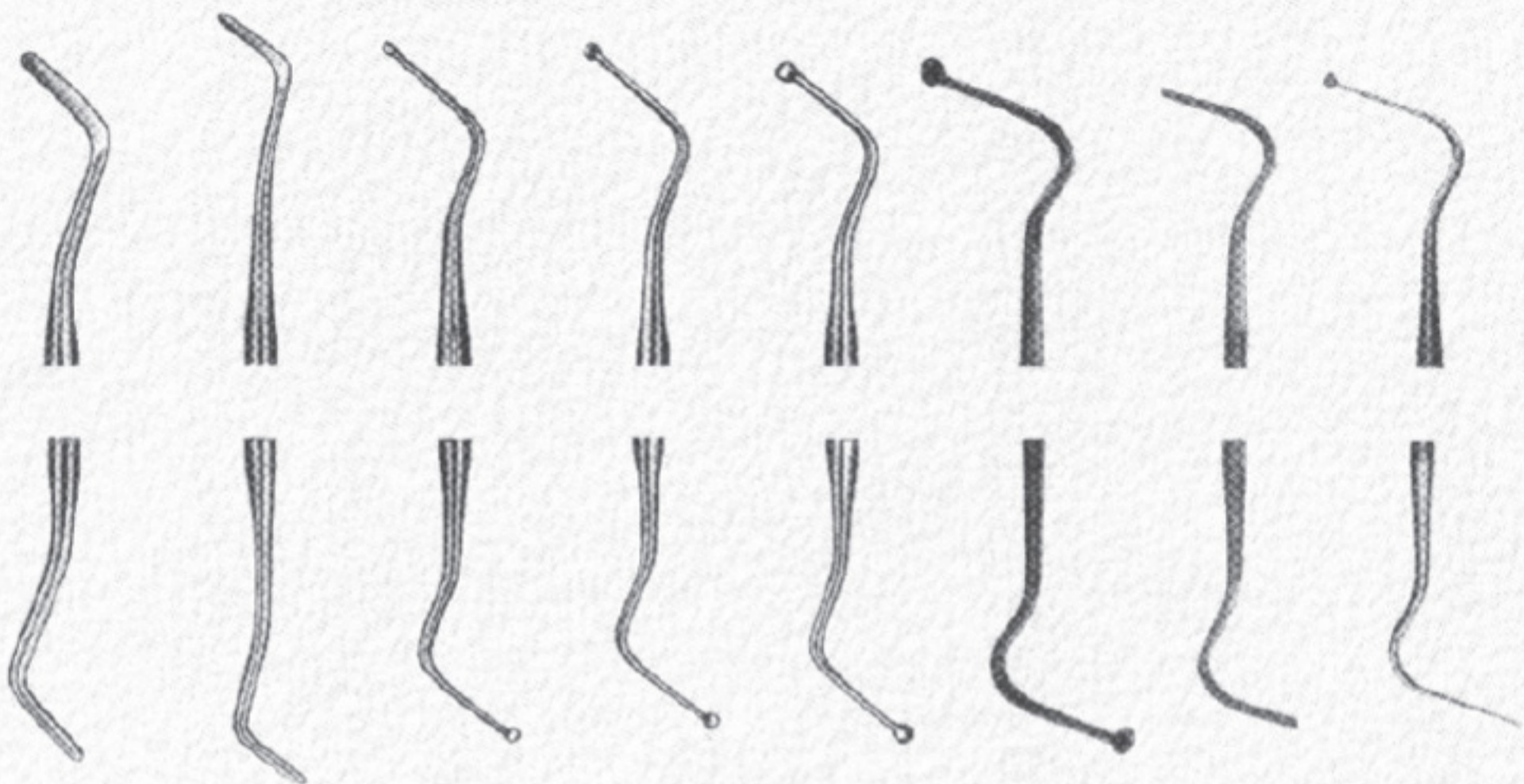

786-822
Fig. 63/64

786-823
Fig. 65/66

786-824
Fig.31L

786-825
Fig.32L

786-826
Fig.33L

786-827
Fig.135/136

786-828
Fig.139/140

786-829
Fig.141/142

root canal excavators

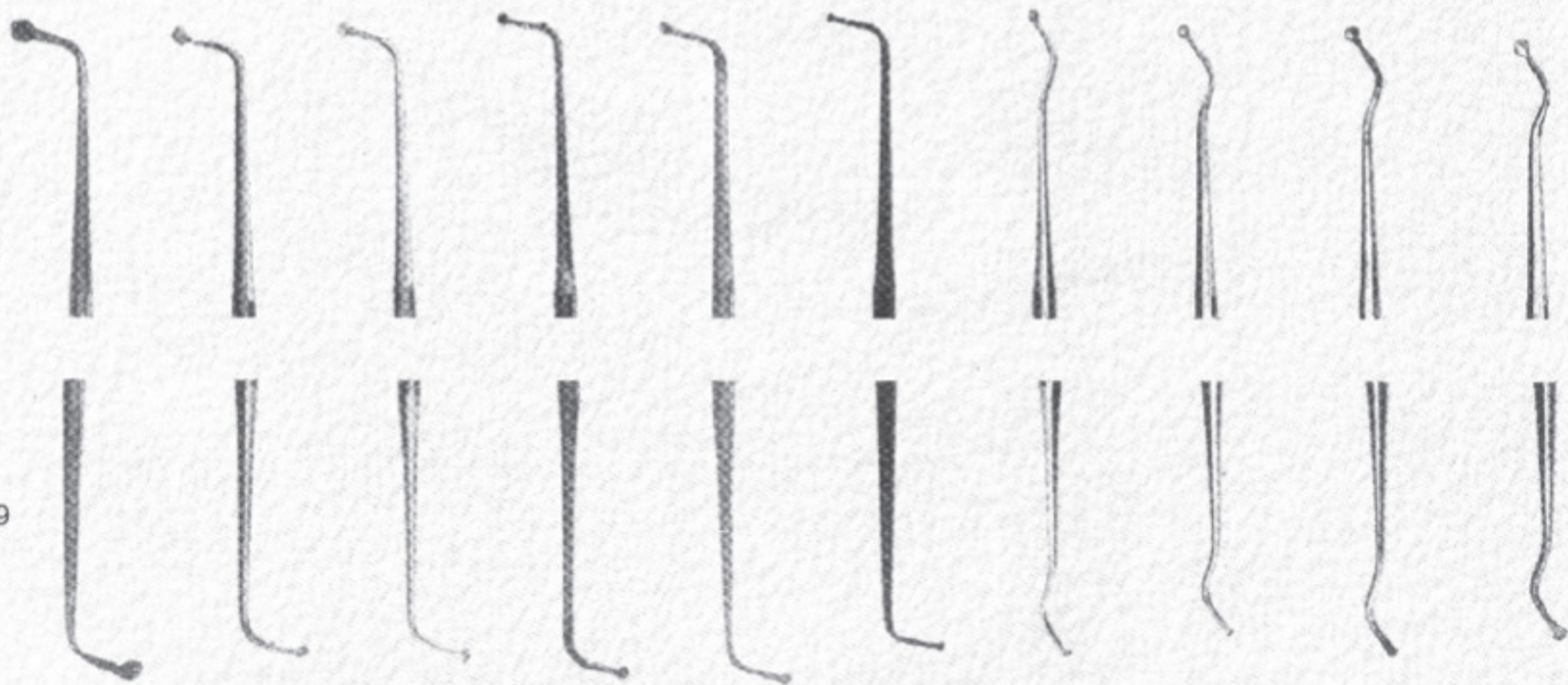

786-830
Fig.113/114

786-831
Fig.115/116

786-832
Fig.117/118

786-833
Fig.119/120

786-834
Fig.121/122

786-835
Fig.123/124

786-836
Fig.153/154

786-837
Fig.155/156

786-838
Fig.157/158

786-839
Fig.159/160



Excavators English Pattern



786-840 Fig. 125/126 786-841 Fig. 127/128 786-842 Fig. 129/130 786-843 Fig. 131/132 786-844 Fig. 133/134 786-845 Fig. 9/10 786-846 Fig. 204/205 786-847 Fig. 206/207 786-848 Fig. 208/209

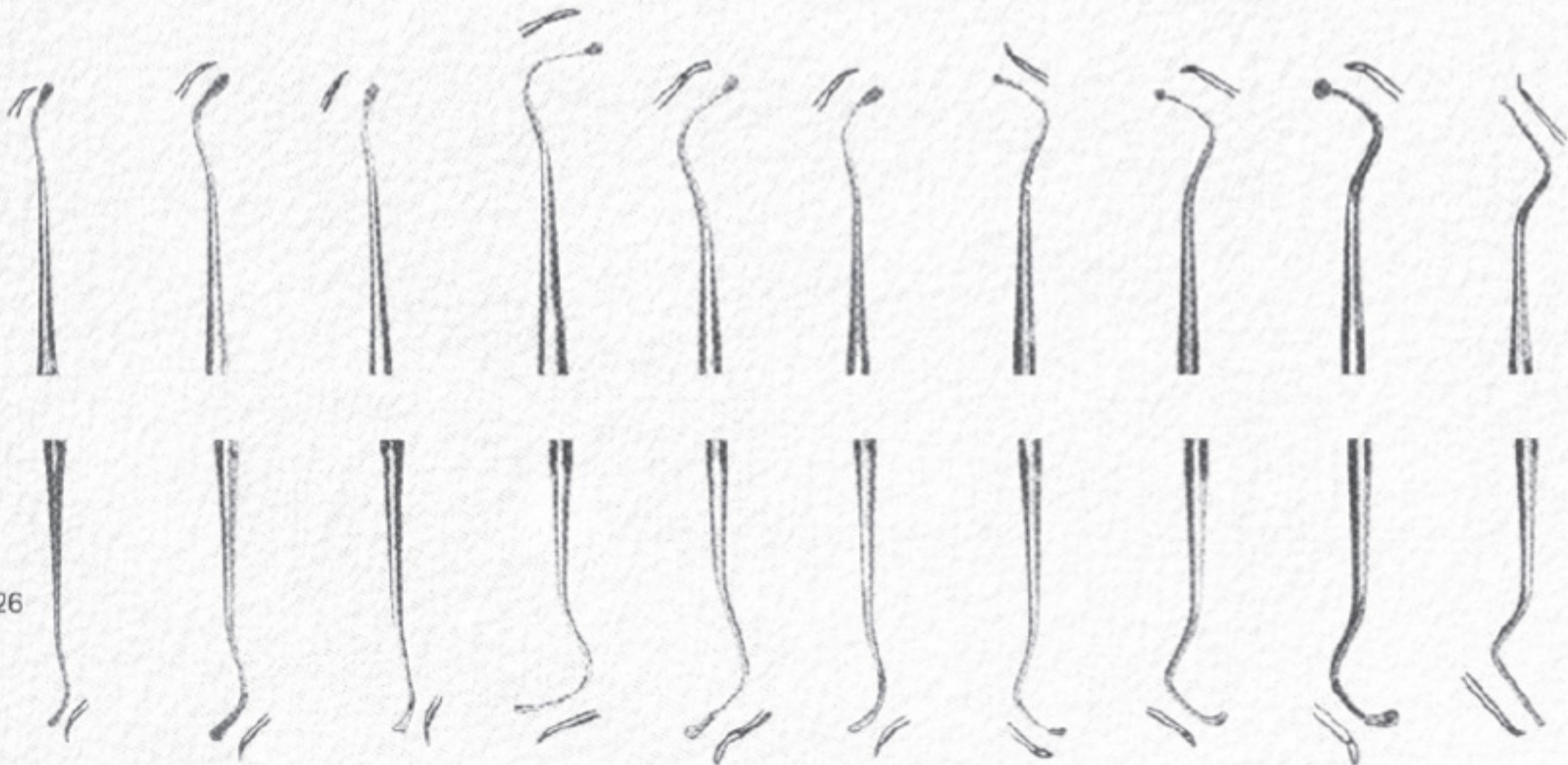

786-840
Fig. 125/126

786-849 Fig. 210/211 786-850 Fig. 212/213 786-851 Fig. 214/215 786-852 Fig. 216/217 786-853 Fig. 218/219 786-854 Fig. 220/221 786-855 Fig. 243 786-856 Fig. 244 786-857 Fig. 245 786-858 Fig. 246



Periodontia Instruments

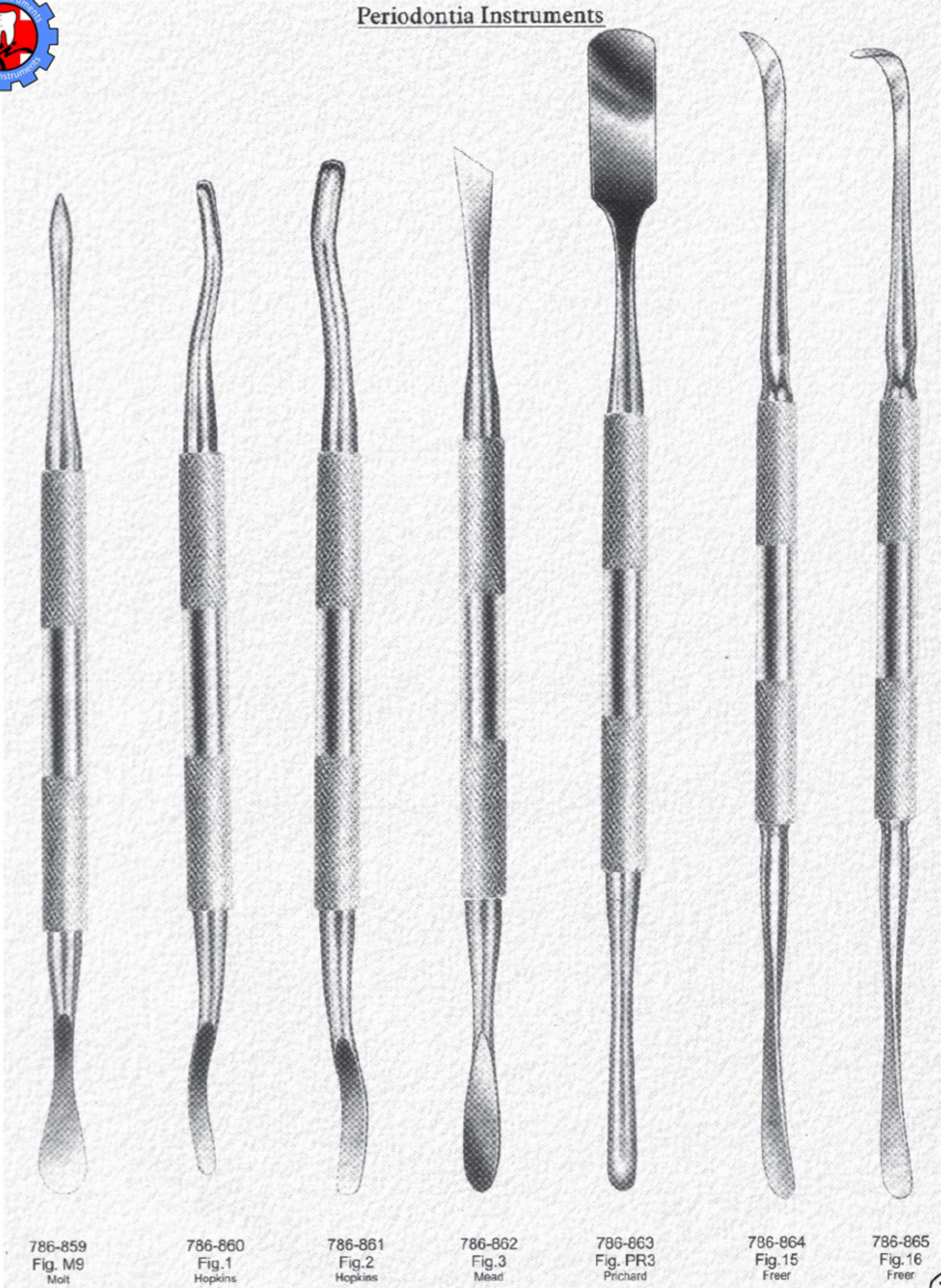



Bone Files

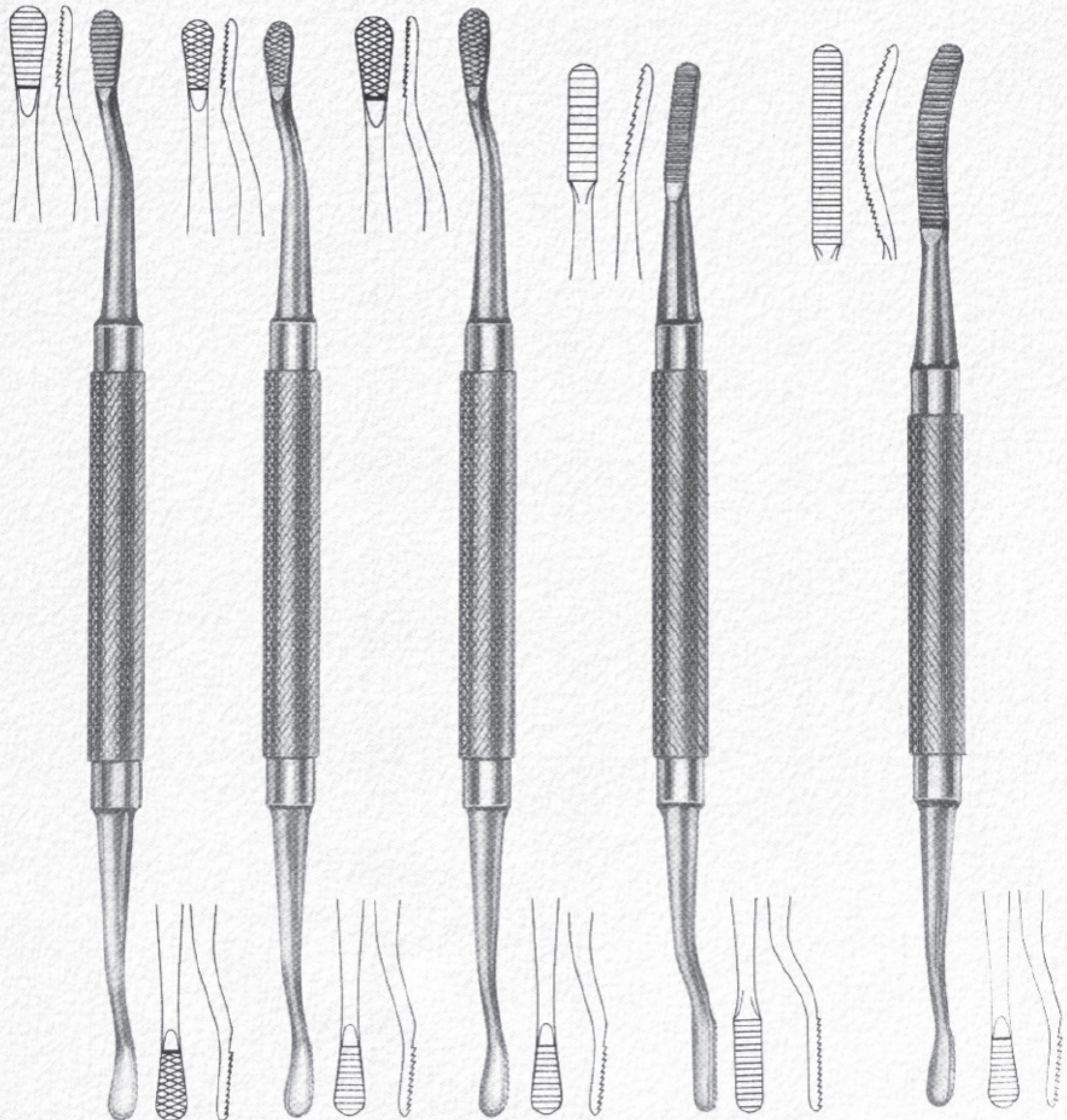

786-866
Fig.12 CA

786-867
Fig.12 A

786-868
Fig.12
Howard

786-869
Fig.33

786-870
Fig.45
Miller



Bone Files

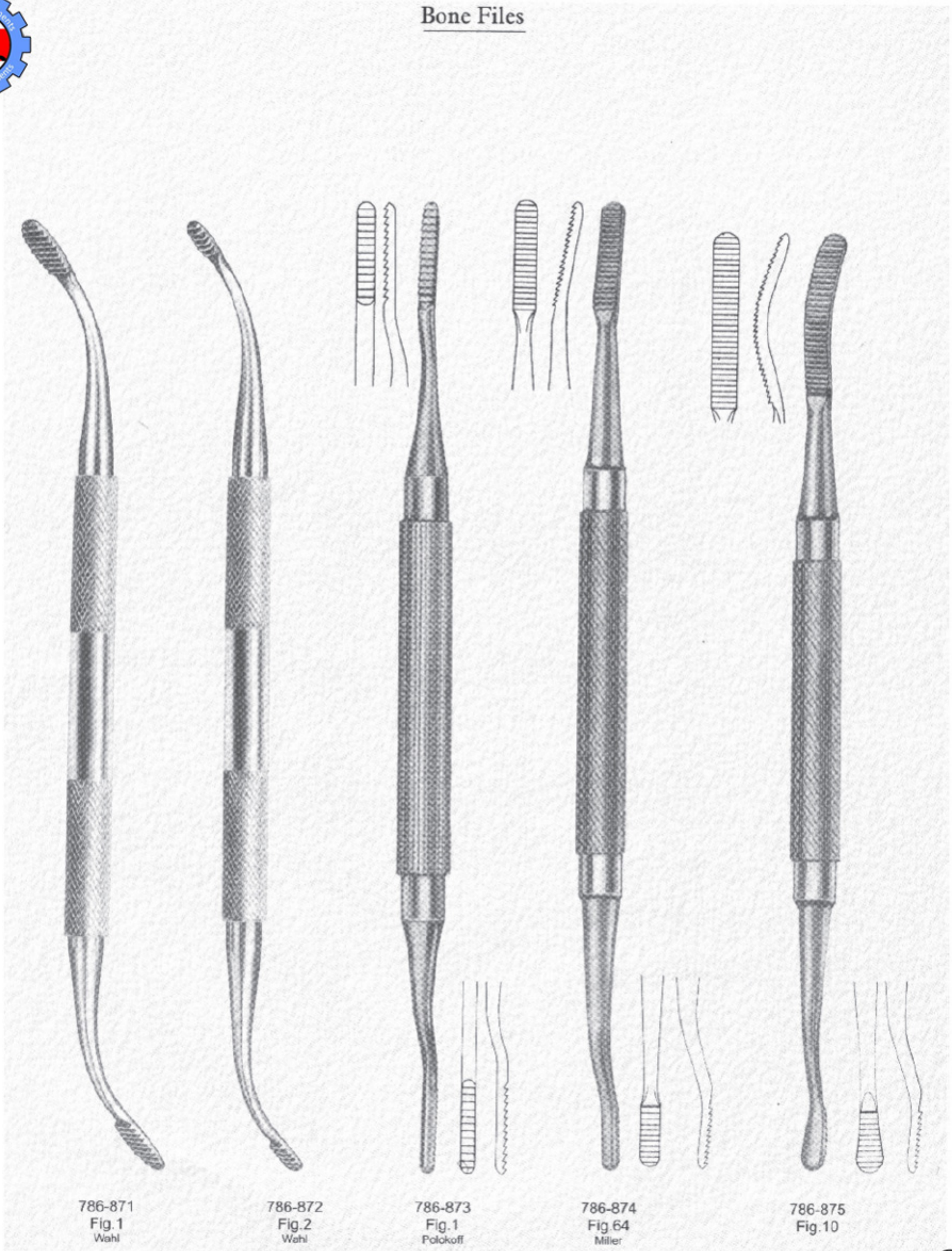

786-871
Fig.1
Wahl

786-872
Fig.2
Wahl

786-873
Fig.1
Polakoff

786-874
Fig.64
Miller

786-875
Fig.10



Bone Currettes Periodontia Instruments

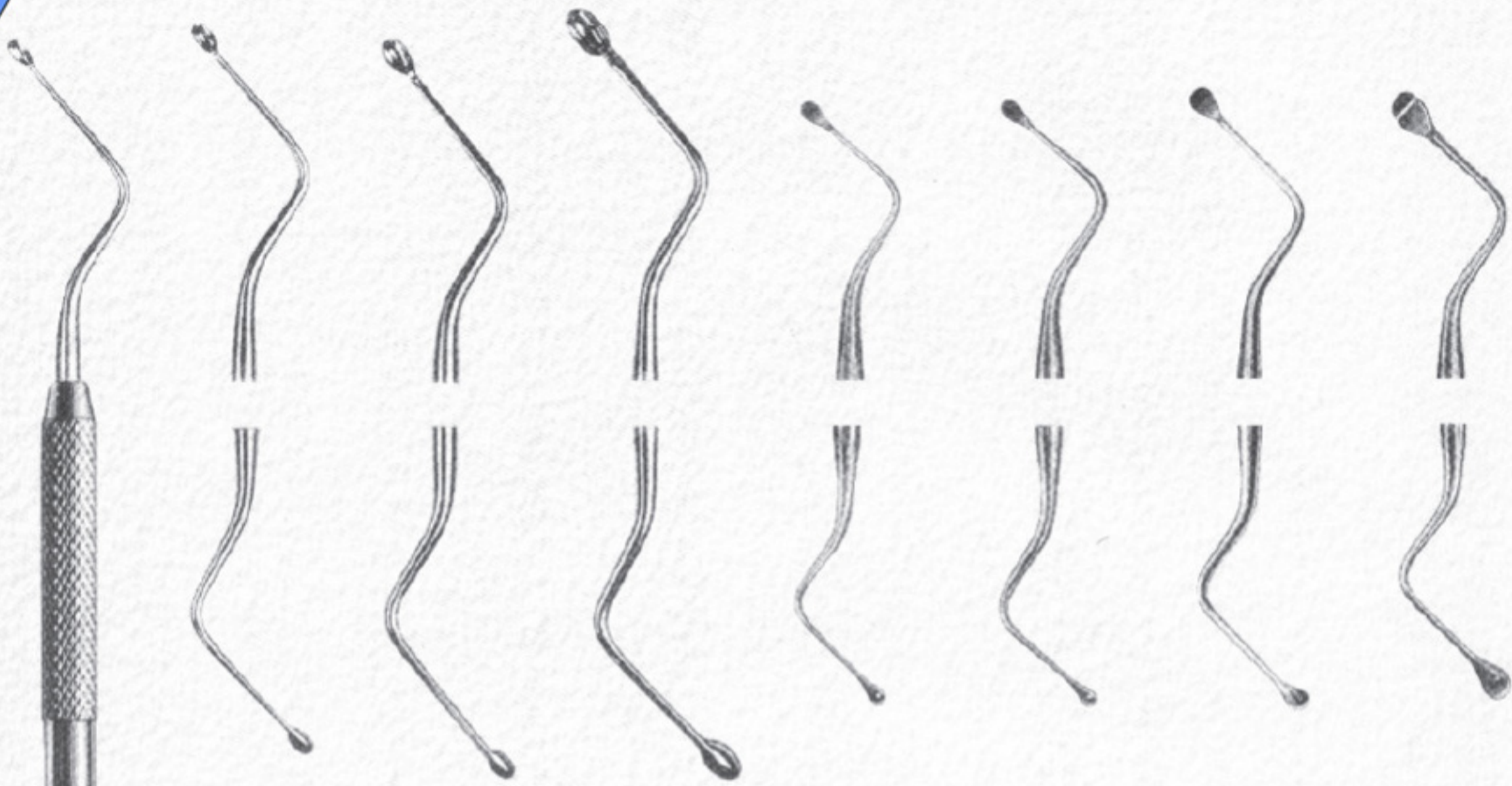

786-877
Fig.2
Hemingway

786-878
Fig.3
Hemingway

786-879
Fig.4
Hemingway

786-880
Fig.85
Lucas

786-881
Fig.86
Lucas

786-882
Fig.87
Lucas

786-883
Fig.88
Lucas

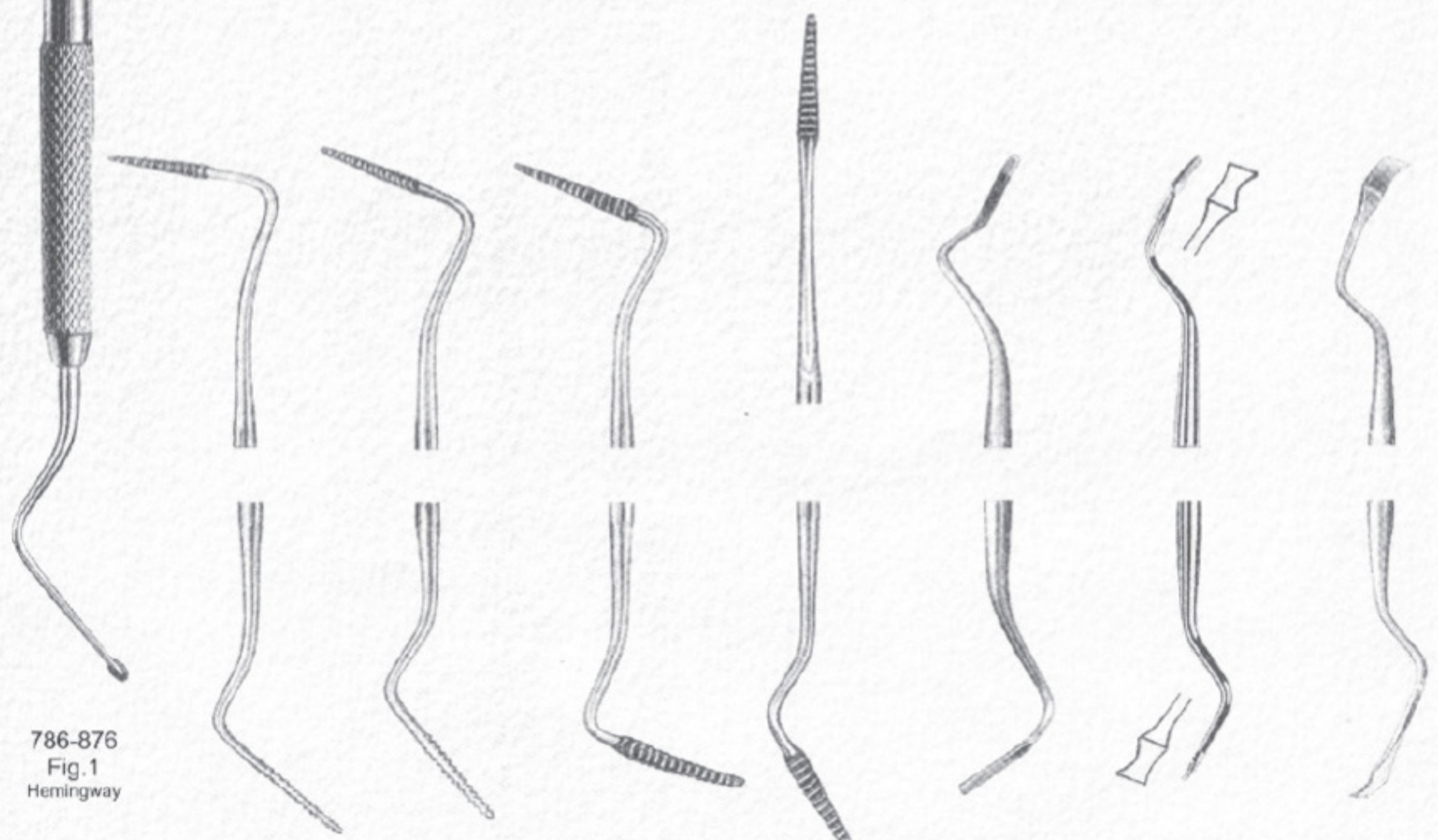

786-876
Fig.1
Hemingway

786-884
Fig.1S/2S
Sugarman

786-885
Fig.3S/4S
Sugarman

786-886
Fig.9/10
Schluger

786-887
Fig.11/12
Buck

786-888
Fig.3
Ochsenbein

786-889
Fig.4
Ochsenbein

786-890
Fig.36/37
Rhodes Back-Action



Periodontia Instruments

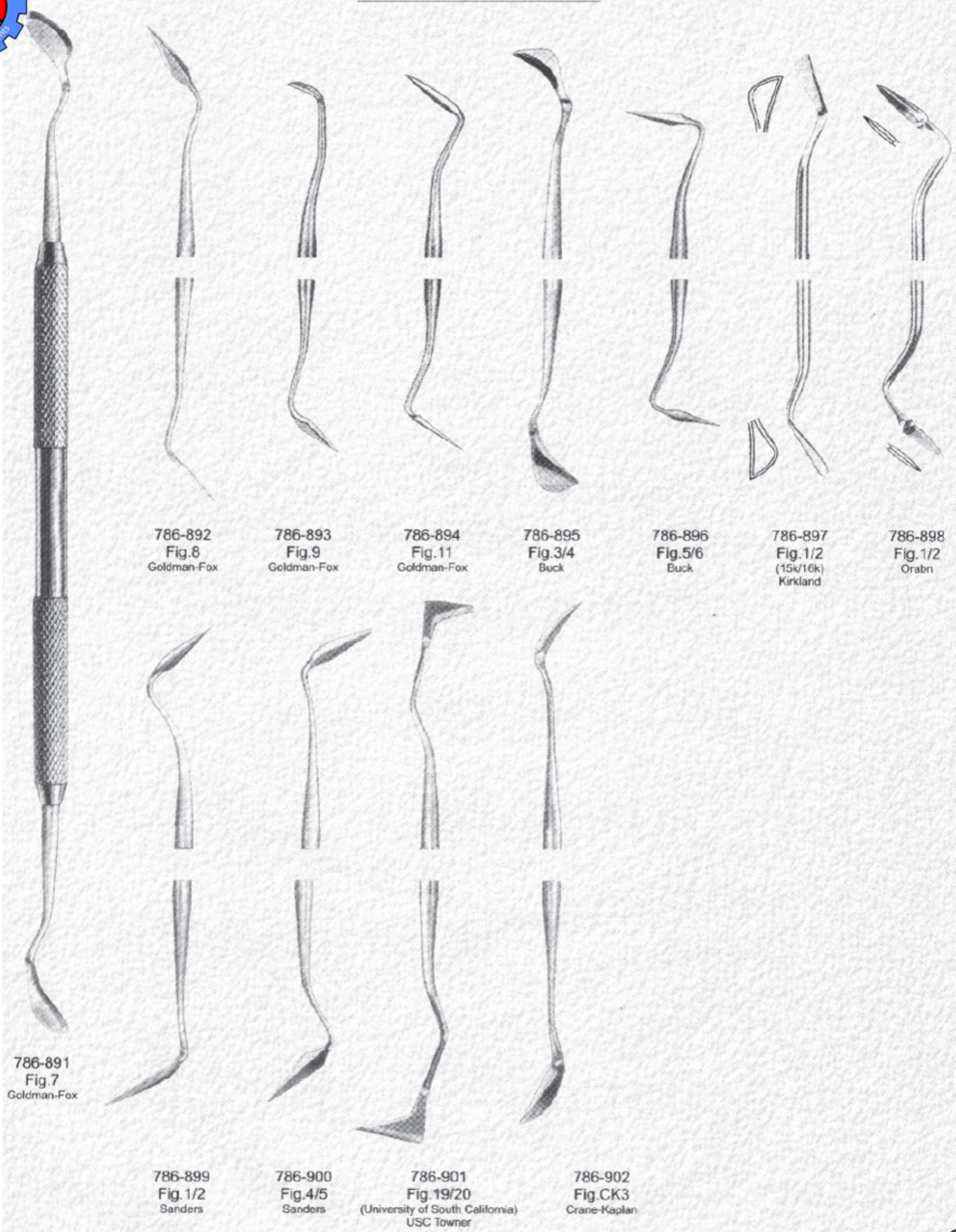



currettes and scalers

Periodontia Instruments



786-904
Fig.2R/2L
Columbia



786-905
Fig.4R/4L
Columbia



786-906
Fig.13/14
Columbia



786-907
Fig.411/412

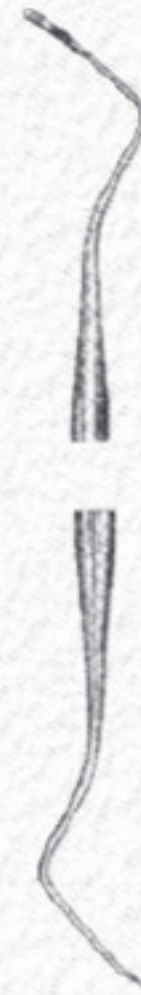

786-908
Fig.413/414



786-909
Fig.1/2
Langer



786-910
Fig.3/4
Langer

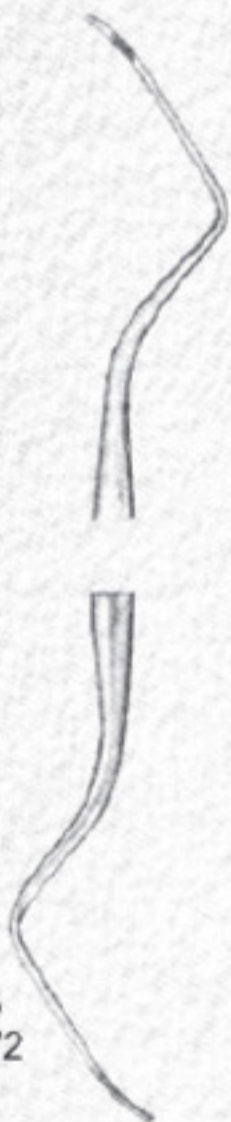

786-911
Fig.1/2
Barnhart



786-912
Fig.5/6
Barnhart



786-913
Fig.ME-1
[10/11]



786-914
Fig.3/4
Rule[23/24]



786-915
Fig.11/14
Gracey
Mesial-Distal



786-916
Fig.12/13
Gracey
Mesial-Distal



786-917
Fig.13/14
Indiana University
Anterior



786-918
Fig.17/18
Indiana University
Posterior

Periodontia Instruments Gracey Curettes



Set of 9 025-286AS
Set of 7 025-280S

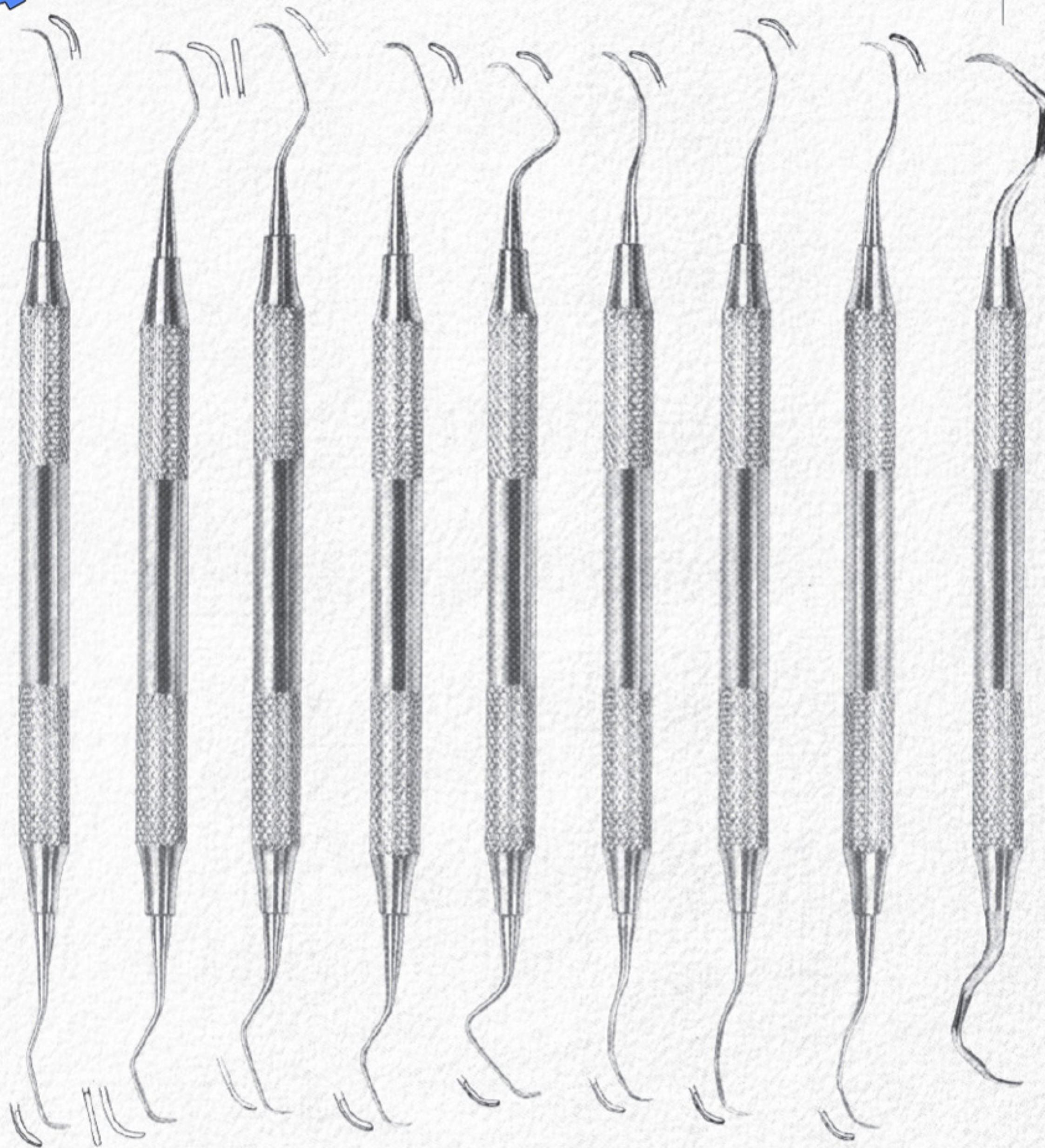

786-919
Fig.1/2
Gracey

786-920
Fig.3/4
Gracey

786-921
Fig.5/6
Gracey

786-922
Fig.7/8
Gracey

786-923
Fig.9/10
Gracey

786-924
Fig.11/12
Gracey

786-925
Fig.13/14
Gracey

786-926
Fig.15/16
Gracey

786-927
Fig.17/18
Gracey

Gracey Curettes are also available in rigid points



Periodontia Instruments

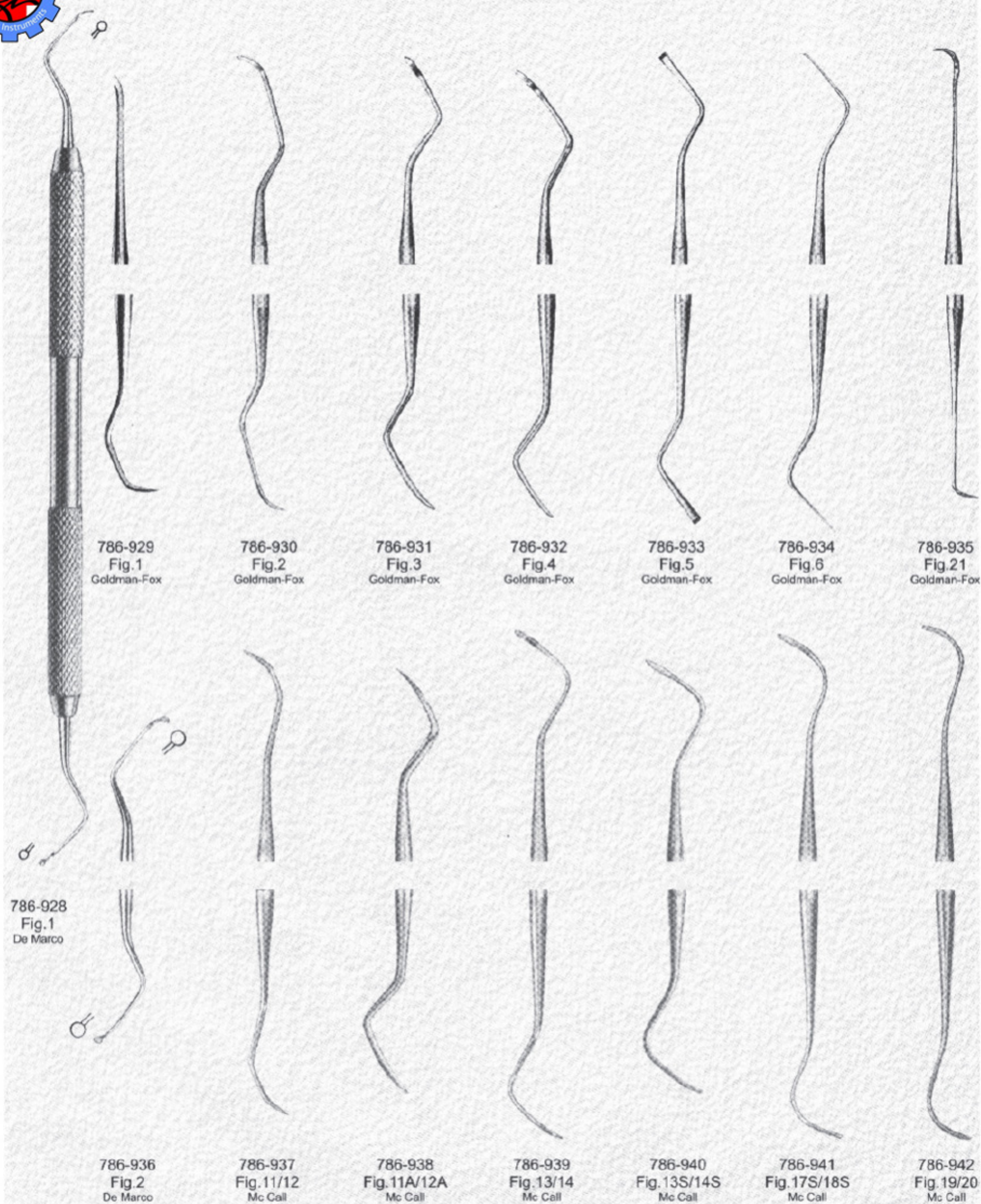



Periodontia Instruments

Scalers

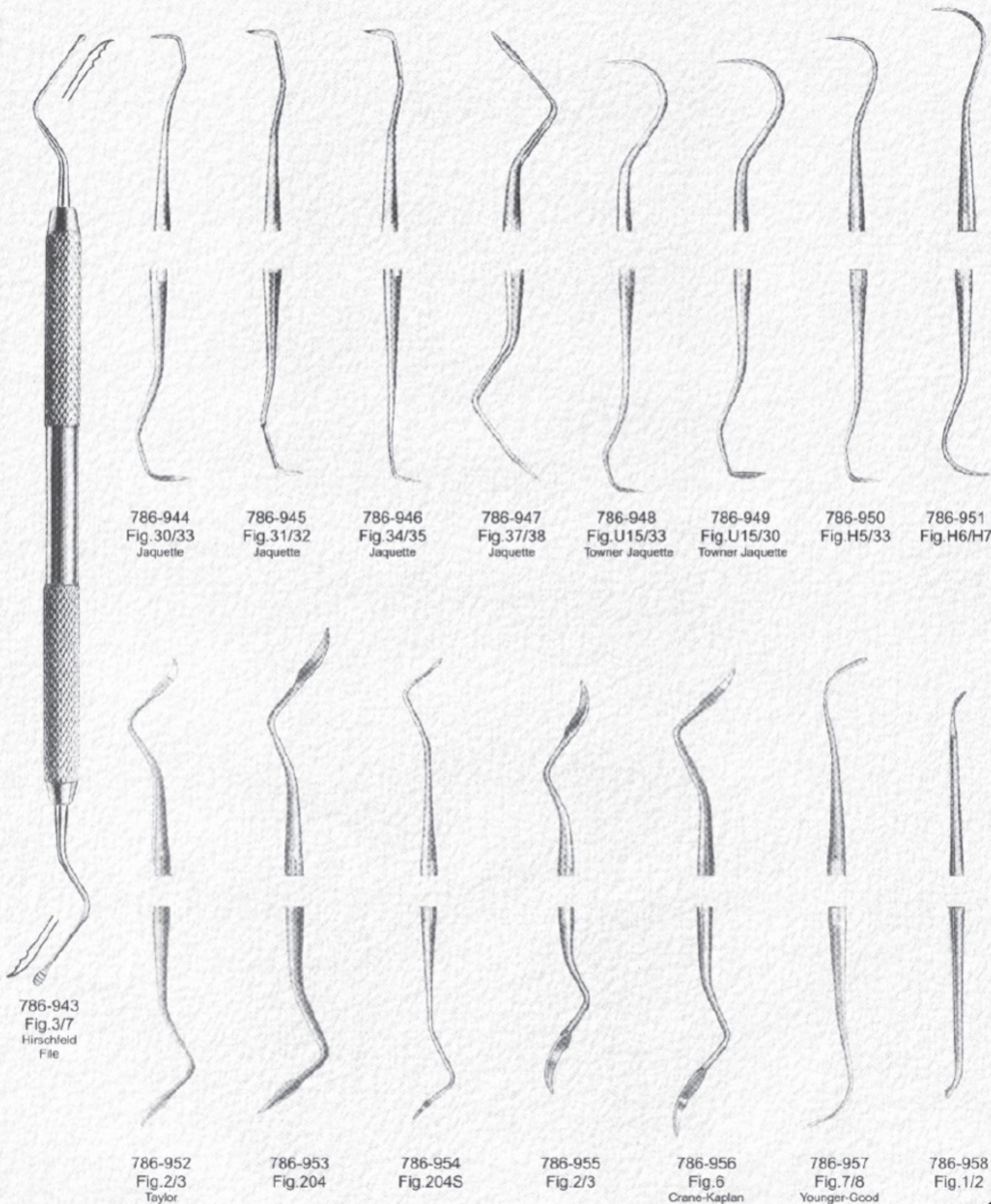



Periodontia Instruments Scalers

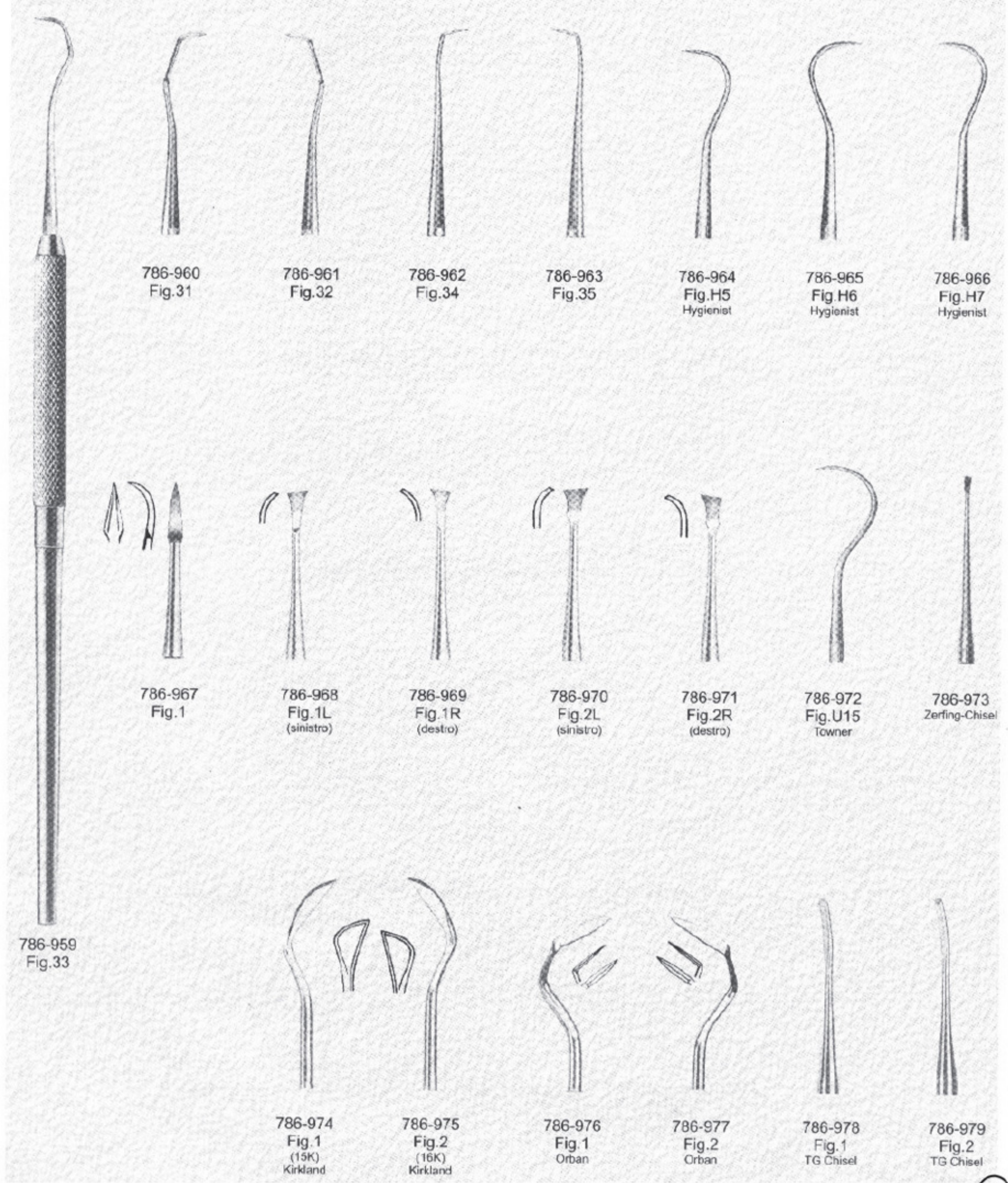

786-960
Fig.31

786-961
Fig.32

786-962
Fig.34

786-963
Fig.35

786-964
Fig.H5
Hygienist

786-965
Fig.H6
Hygienist

786-966
Fig.H7
Hygienist

786-967
Fig.1

786-968
Fig.1L
(sinistro)

786-969
Fig.1R
(destro)

786-970
Fig.2L
(sinistro)

786-971
Fig.2R
(destro)

786-972
Fig.U15
Towner

786-973
Zerfing-Chisel

786-959
Fig.33

786-974
Fig.1
(15K)
Kirkland

786-975
Fig.2
(16K)
Kirkland

786-976
Fig.1
Orban

786-977
Fig.2
Orban

786-978
Fig.1
TG Chisel

786-979
Fig.2
TG Chisel



Cement Spatulas

Heidemann Separating Spatulas

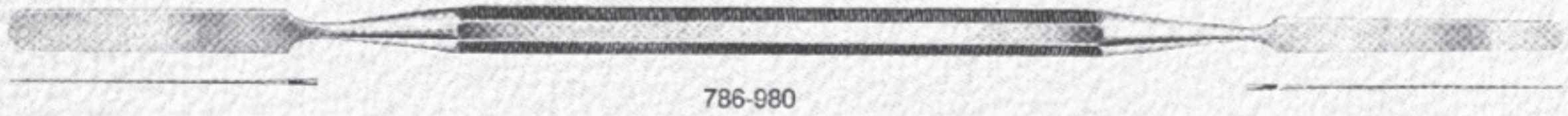

786-980

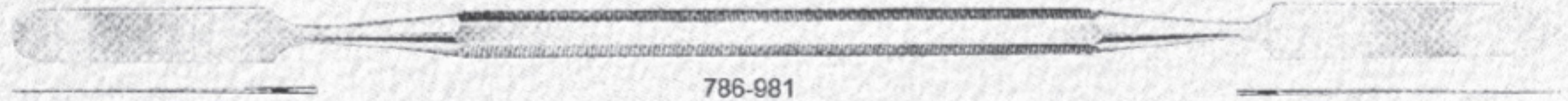

786-981

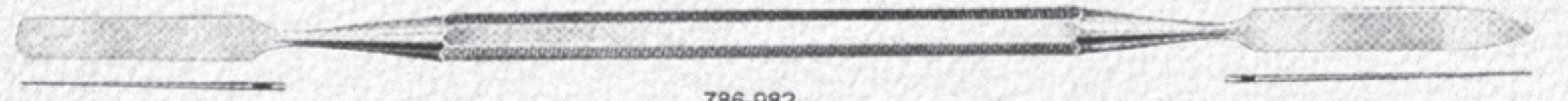

786-982

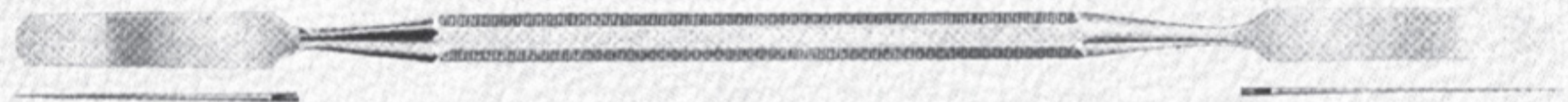

786-983

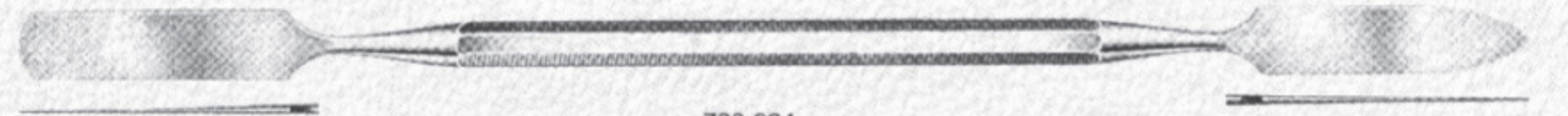

786-984

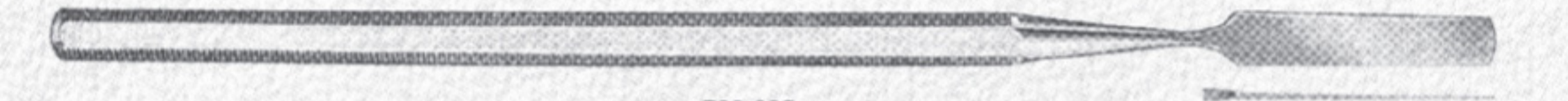

786-985

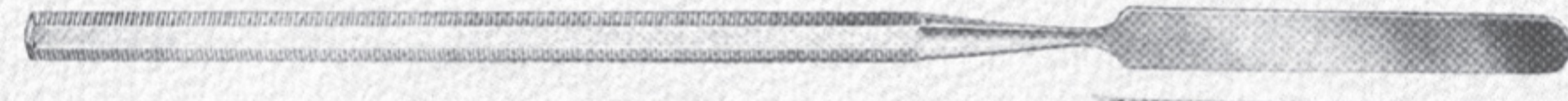

786-986

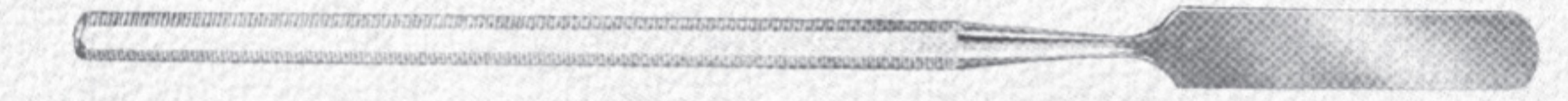

786-987

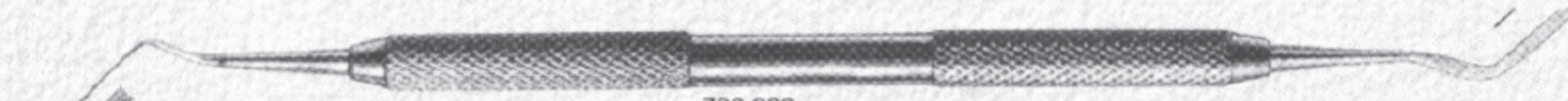

786-988
Fig. 1

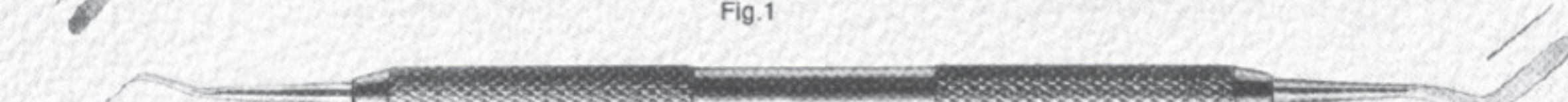

786-989
Fig. 2

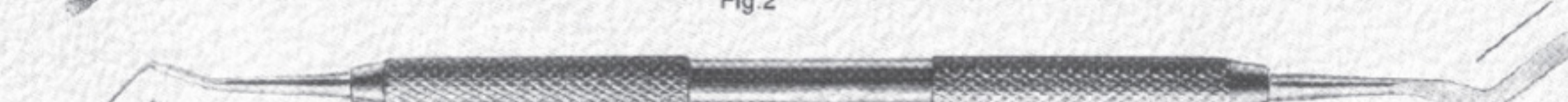

786-990
Fig. 3



Wax and Modelling Carvers

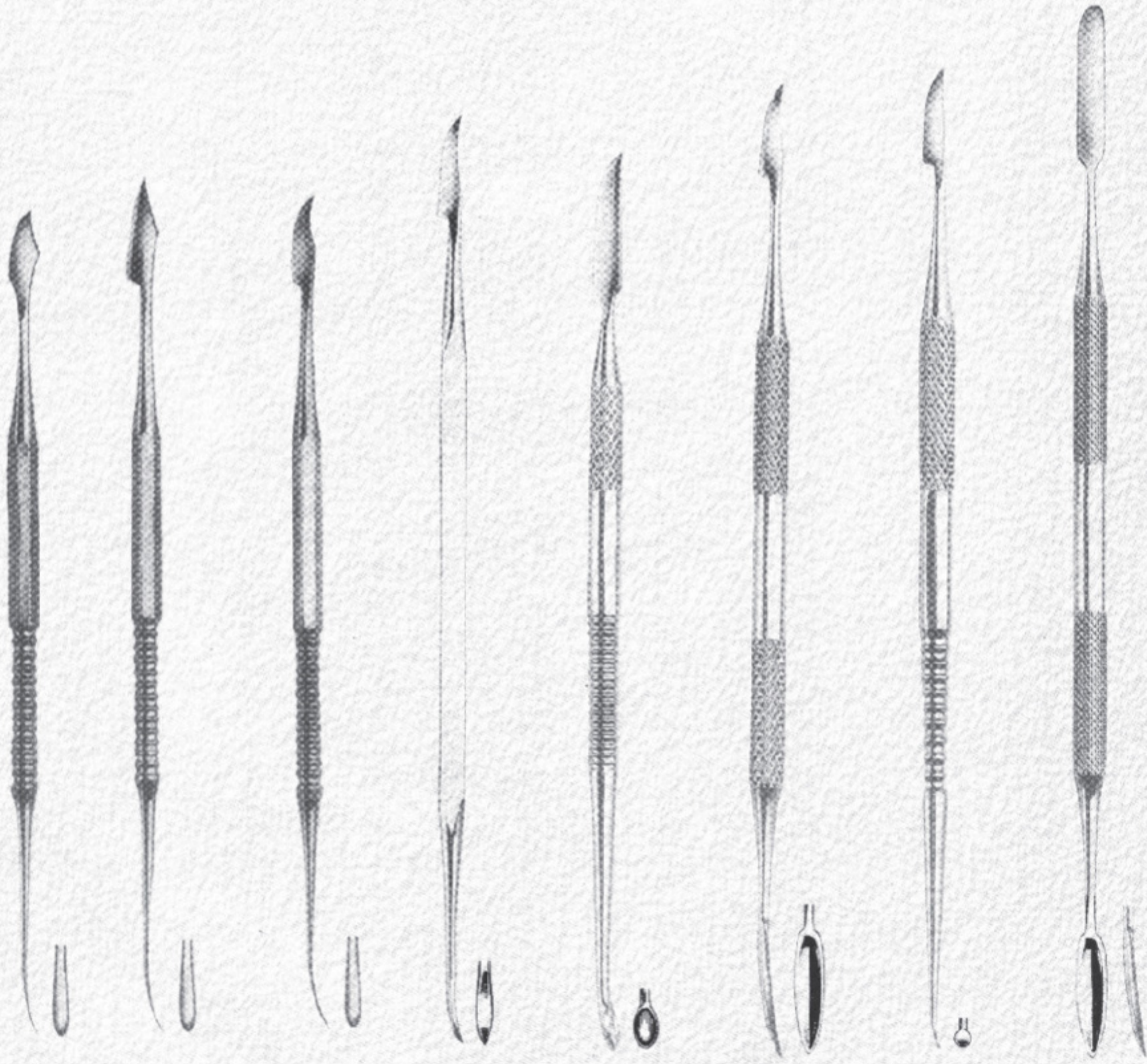

786-991
Zahle

786-992
Zahle

786-993
Zahle

786-994
Hylin

786-995
Hylin-Ceramica

786-996
Hylin-Sacred

786-997
Hylin-Le Cron

786-998
Sacred



Wax and Modelling Carvers

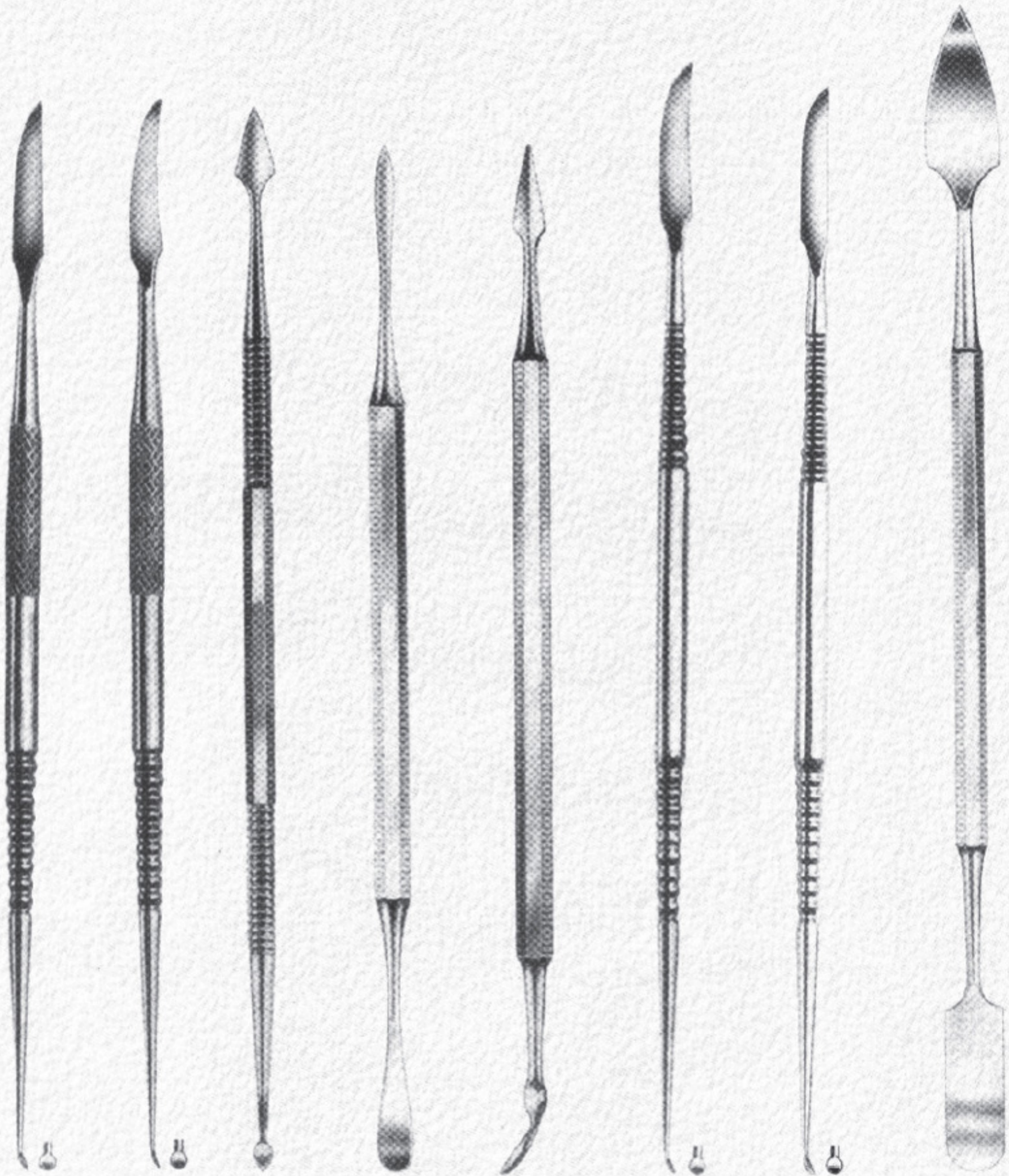

786-999
Le Cron

786-1000
Le Cron

786-1001
Vehe

786-1002
Beale

786-1003
Roach

786-1004
Le Cron

786-1005
Le Cron

786-1006
Gritman



Wax and Modelling Carvers

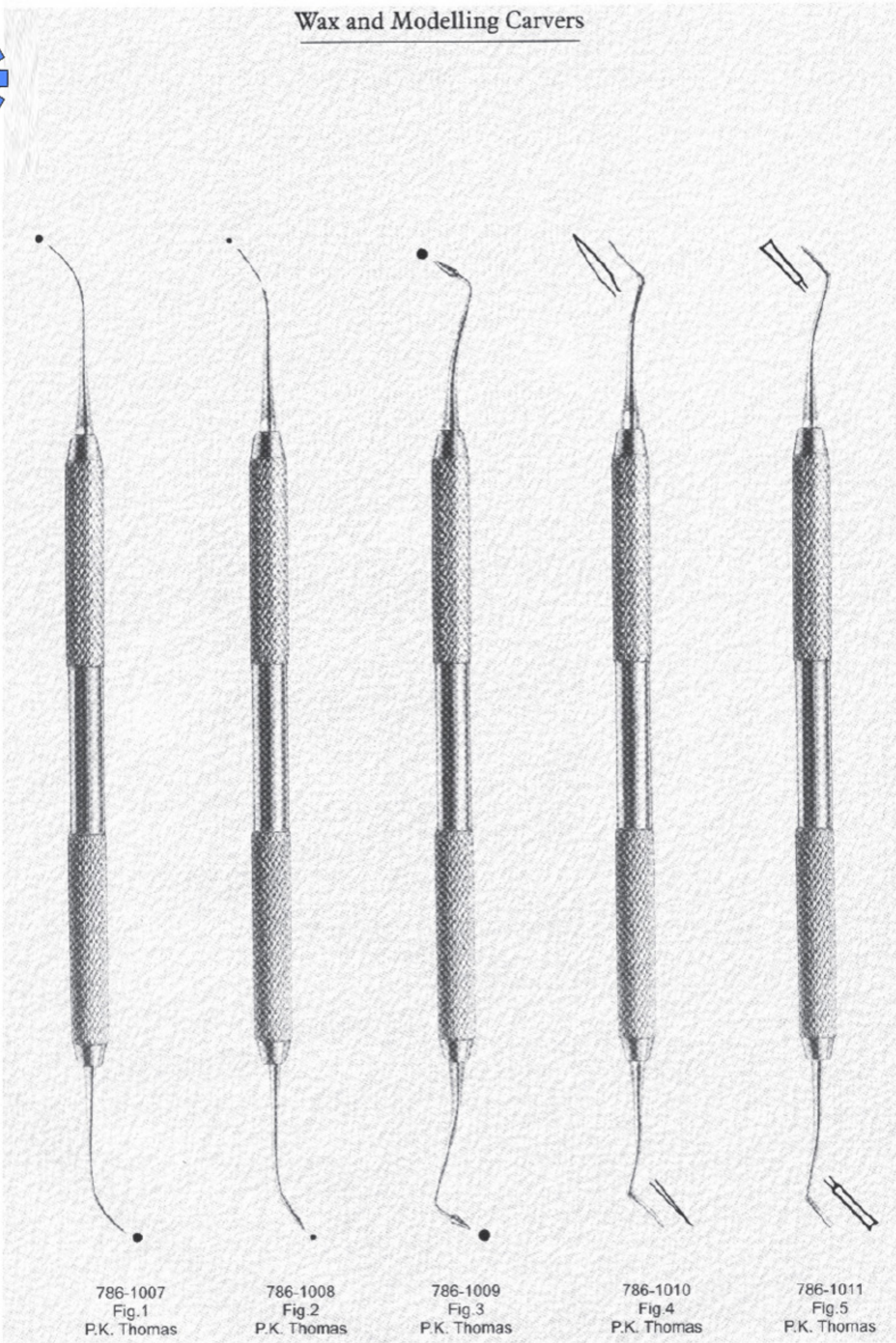

786-1007
Fig.1
P.K. Thomas

786-1008
Fig.2
P.K. Thomas

786-1009
Fig.3
P.K. Thomas

786-1010
Fig.4
P.K. Thomas

786-1011
Fig.5
P.K. Thomas



Wax Knives

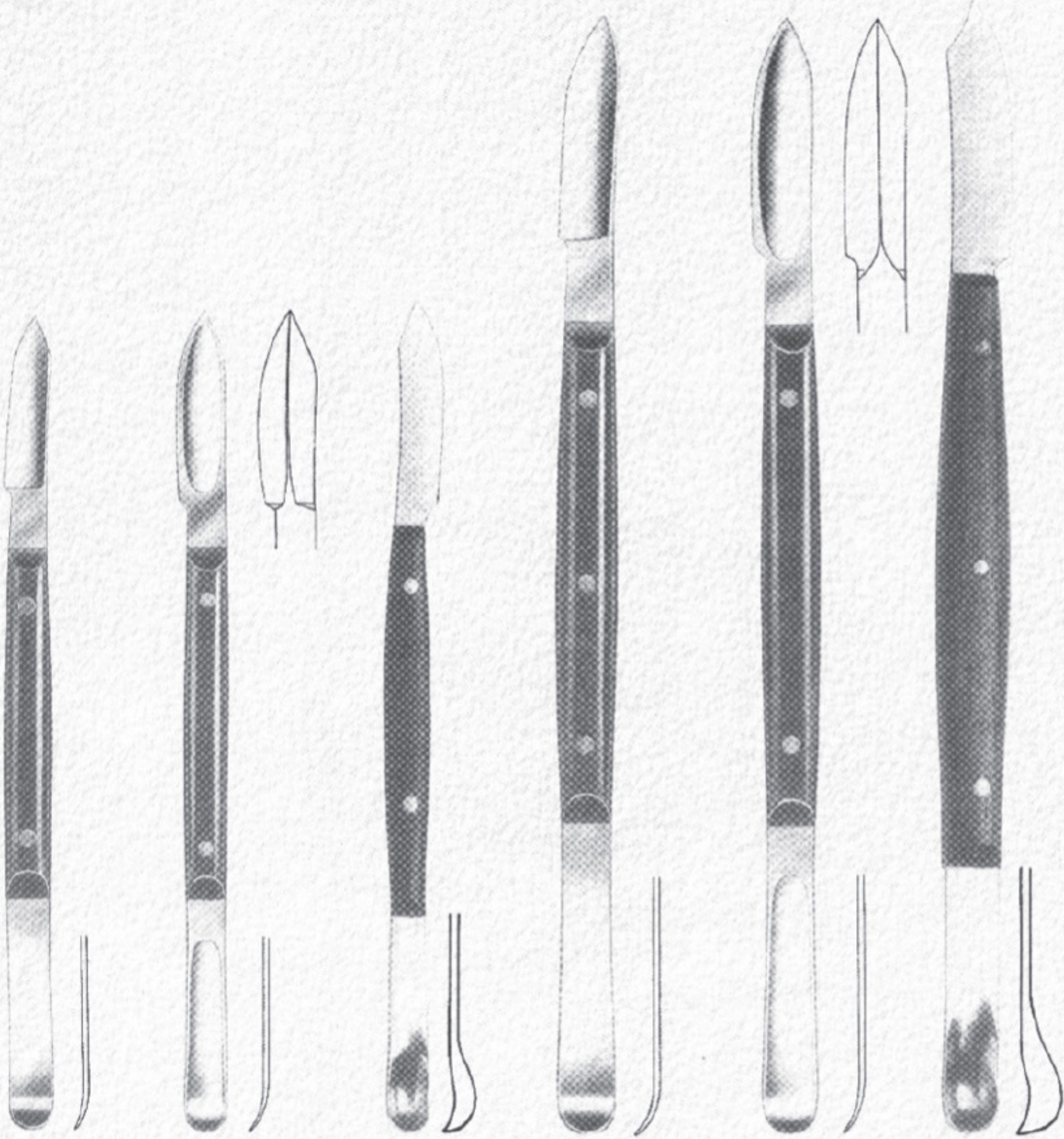

786-1012
Fig.1
Fahnenstock
cm. 12,5

786-1013
Fig.1
Lessmann
cm. 12,5

786-1014
Fig.1
Con Scodellino
cm. 12,5

786-1015
Fig.2
Fahnenstock
cm. 17

786-1016
Fig.2
Lessmann
cm. 17

786-1017
Fig.2
Con Scodellino
cm. 17



Amalgam Carriers

Ø1,5 mm

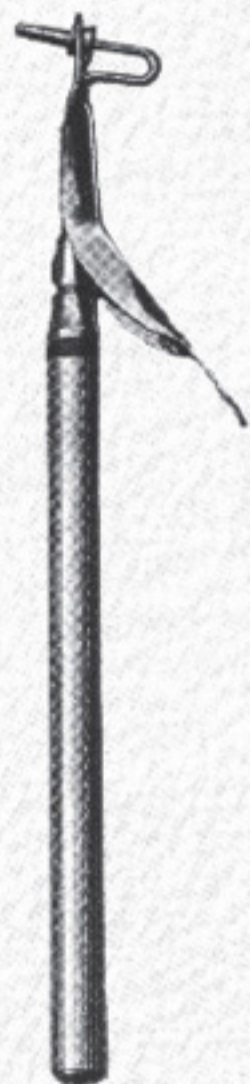

786-1026
Small

Ø2 mm



786-1027
Medium

Ø2,5 mm

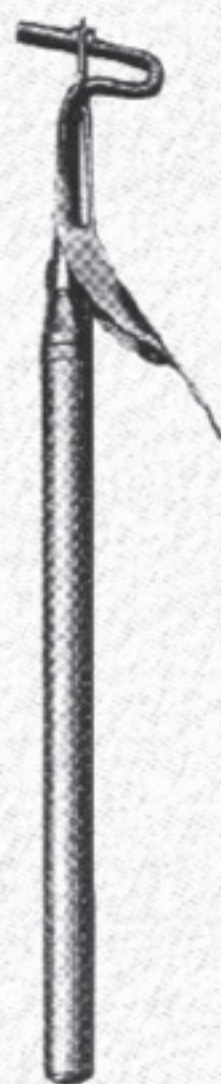

786-1028
Large

Ø3 mm



786-1029
Jumbo

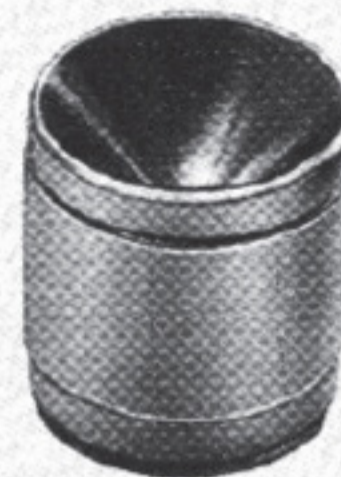

786-1030
Amalgam well

Ø2 mm

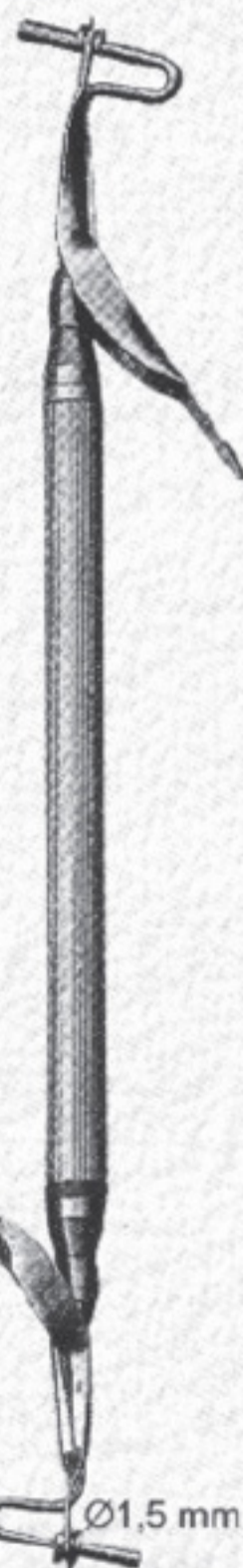

786-1031
Medium /Small

Ø2 mm

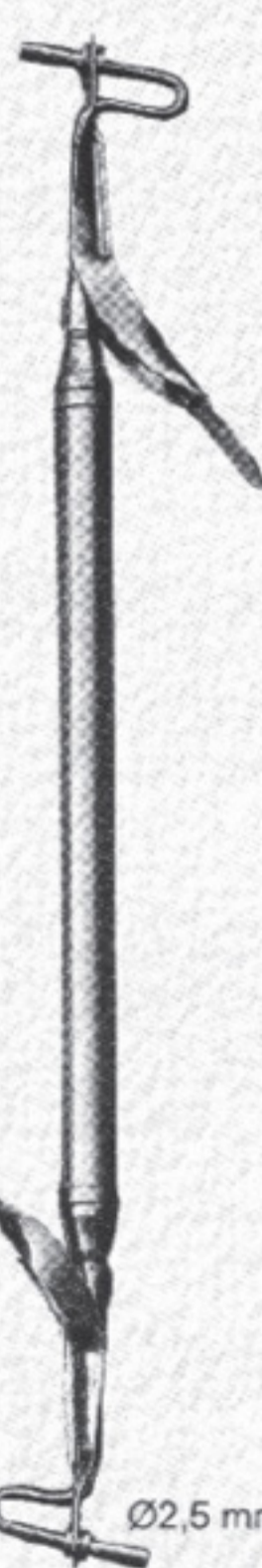

786-1032
Medium /Large

Ø2 mm

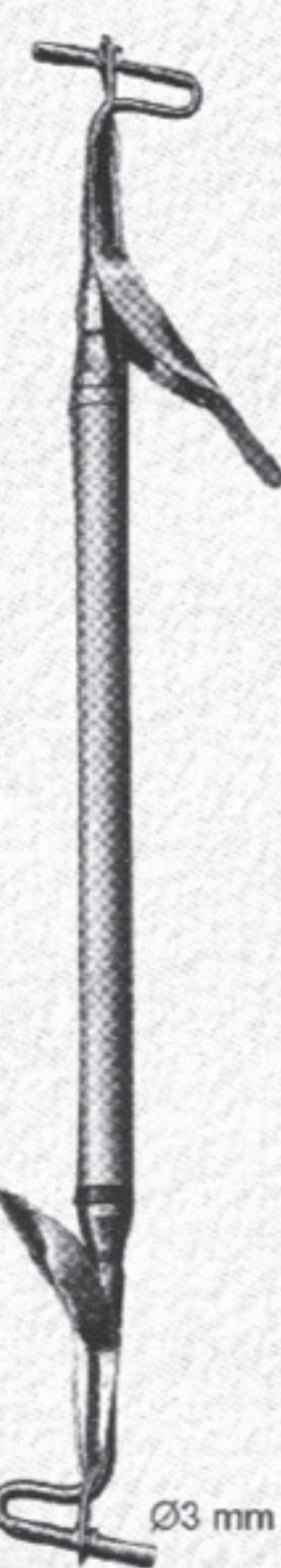

786-1033
Medium /Jumbo

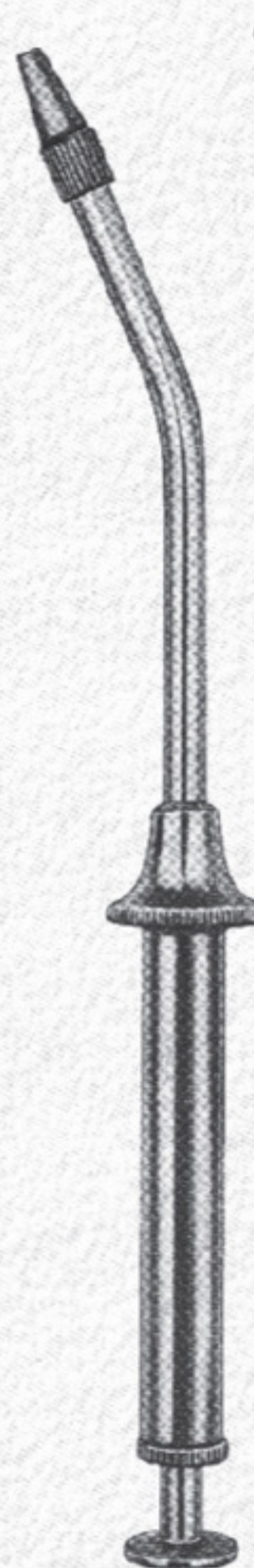

786-1034

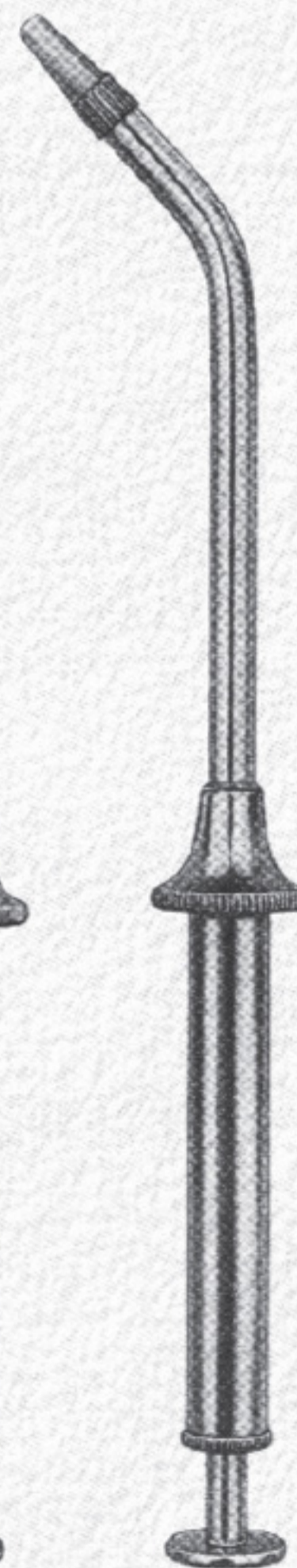

786-1035

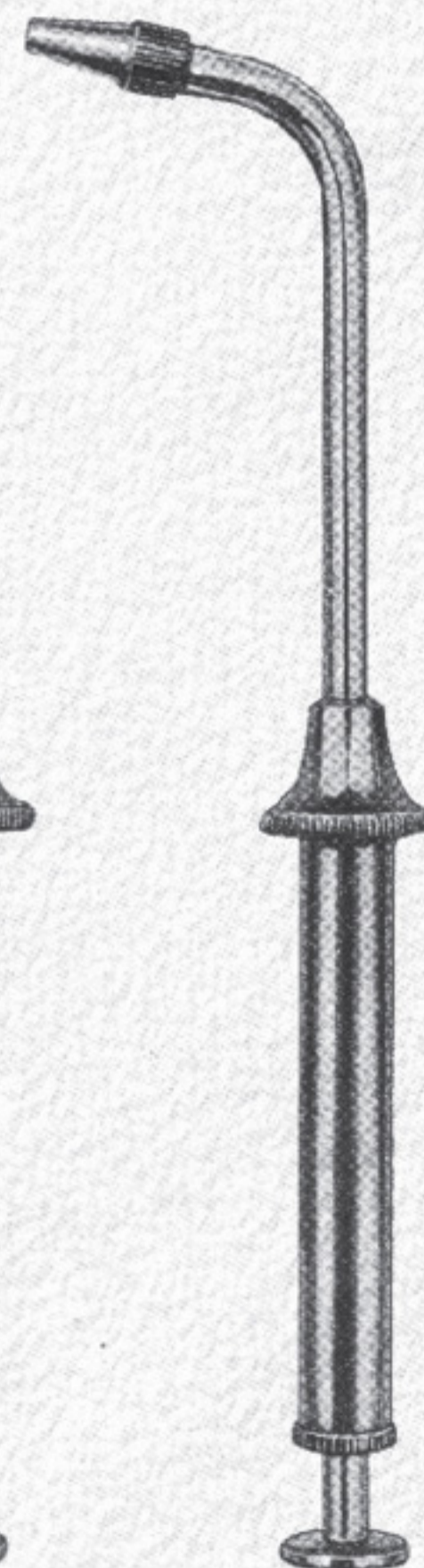

786-1036



Dental Cartridge Syringes

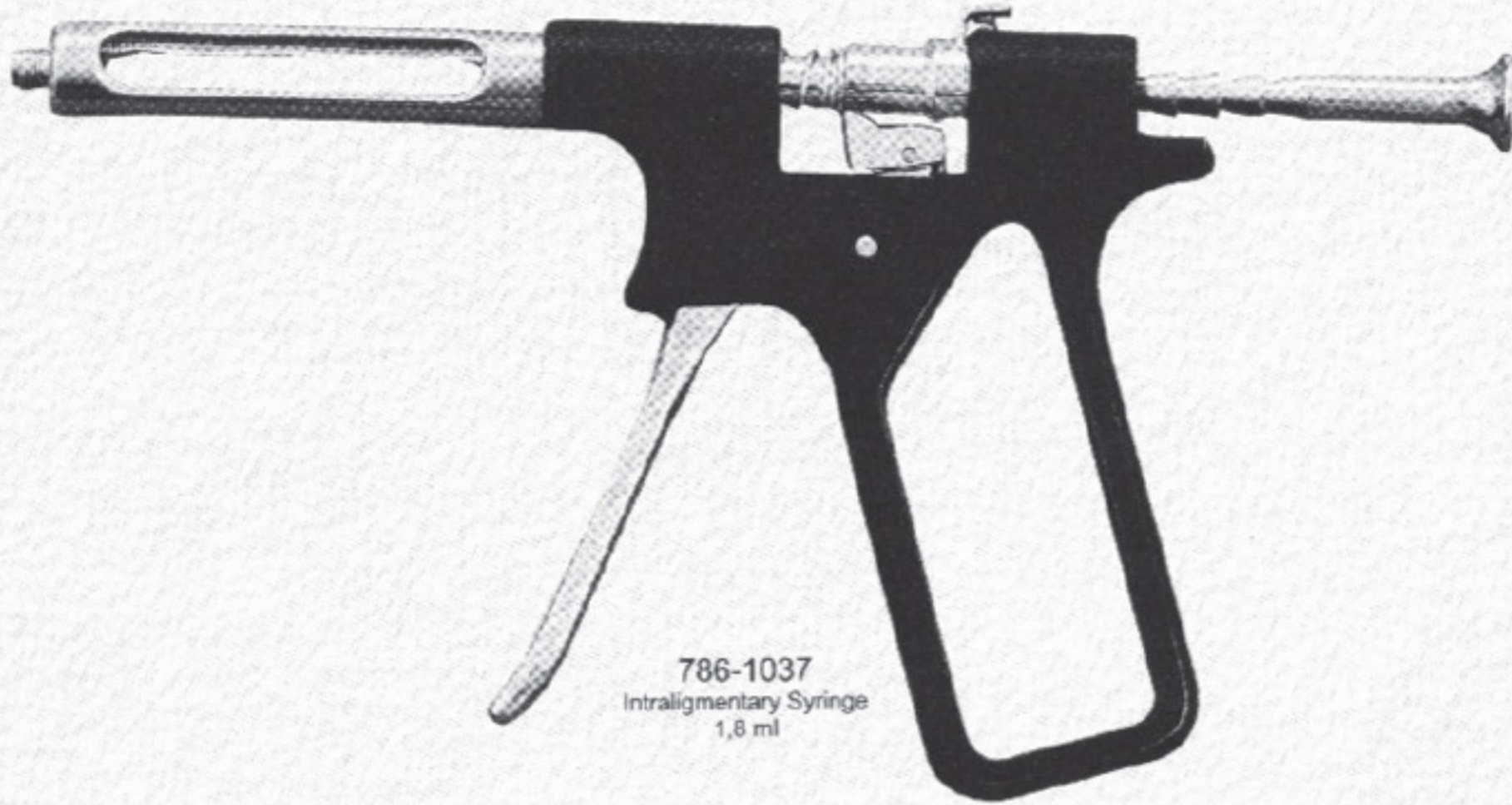

786-1037
Intraligmentary Syringe
1,8 ml

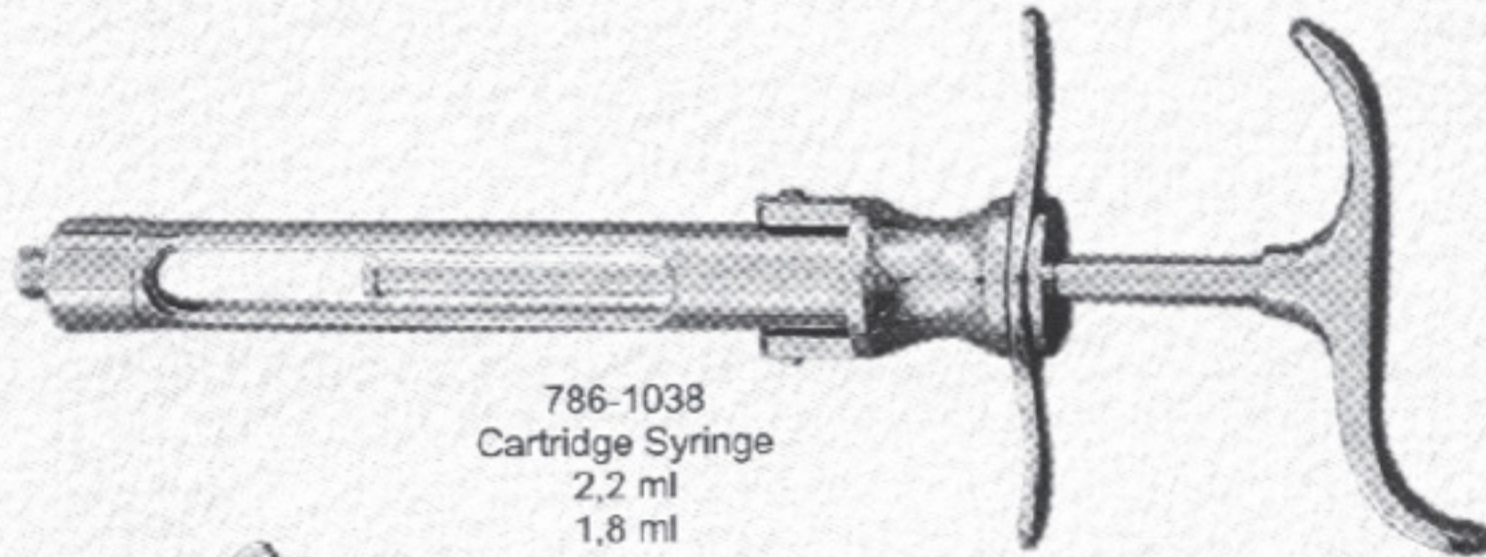

786-1038
Cartridge Syringe
2,2 ml
1,8 ml

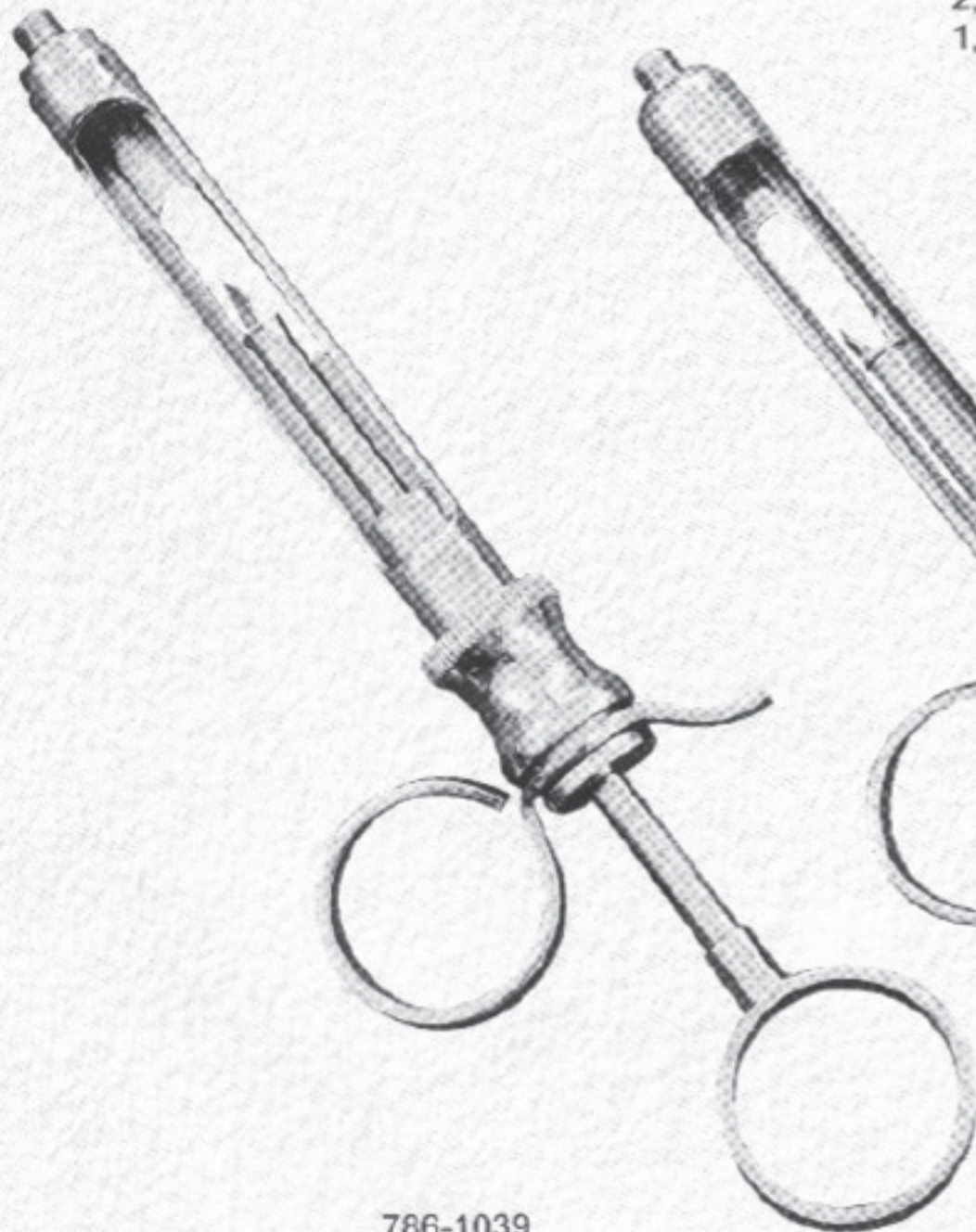

786-1039
Aspirated Syringe
1,8 ml

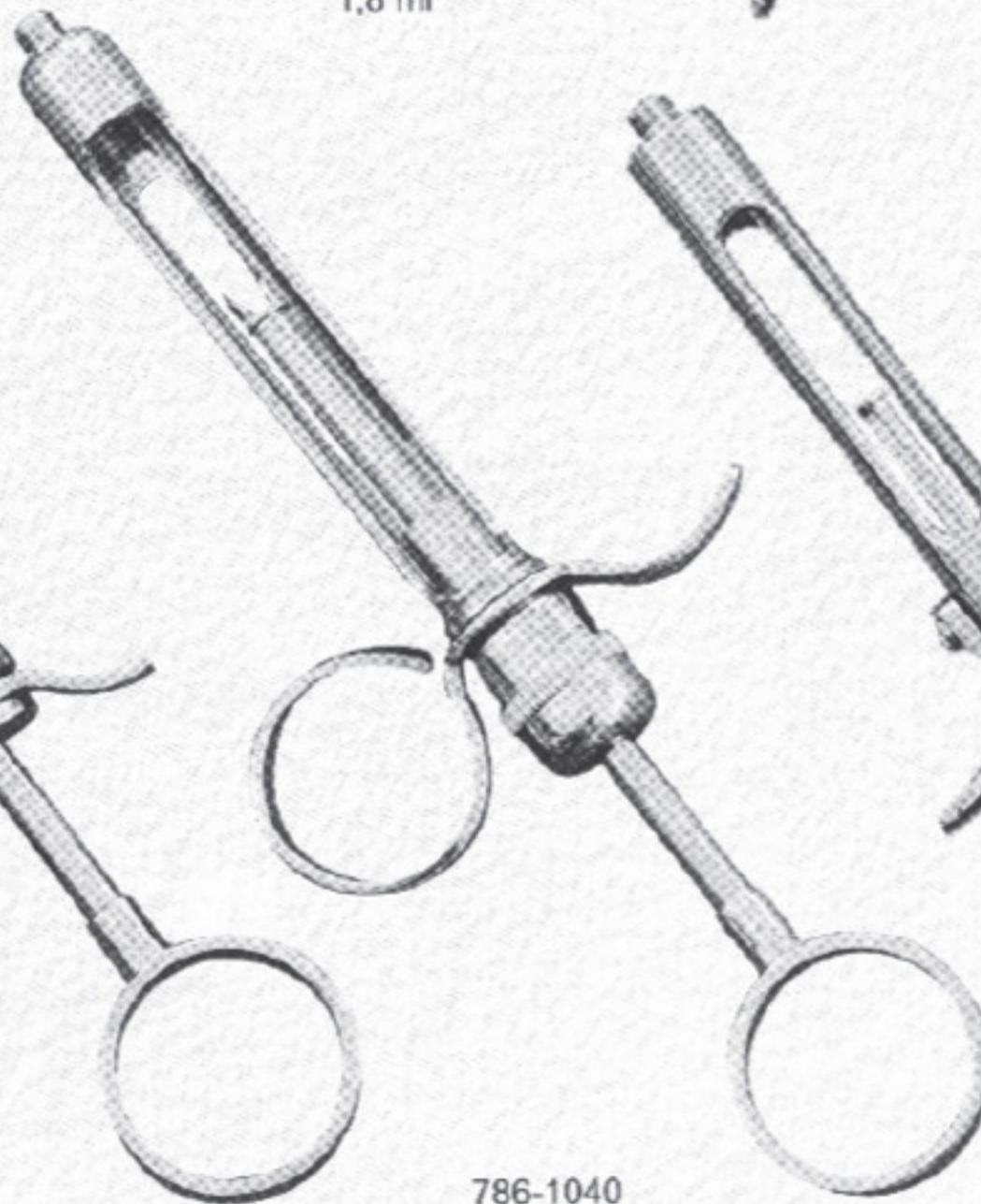

786-1040
Aspirated Syringe
1,8 ml

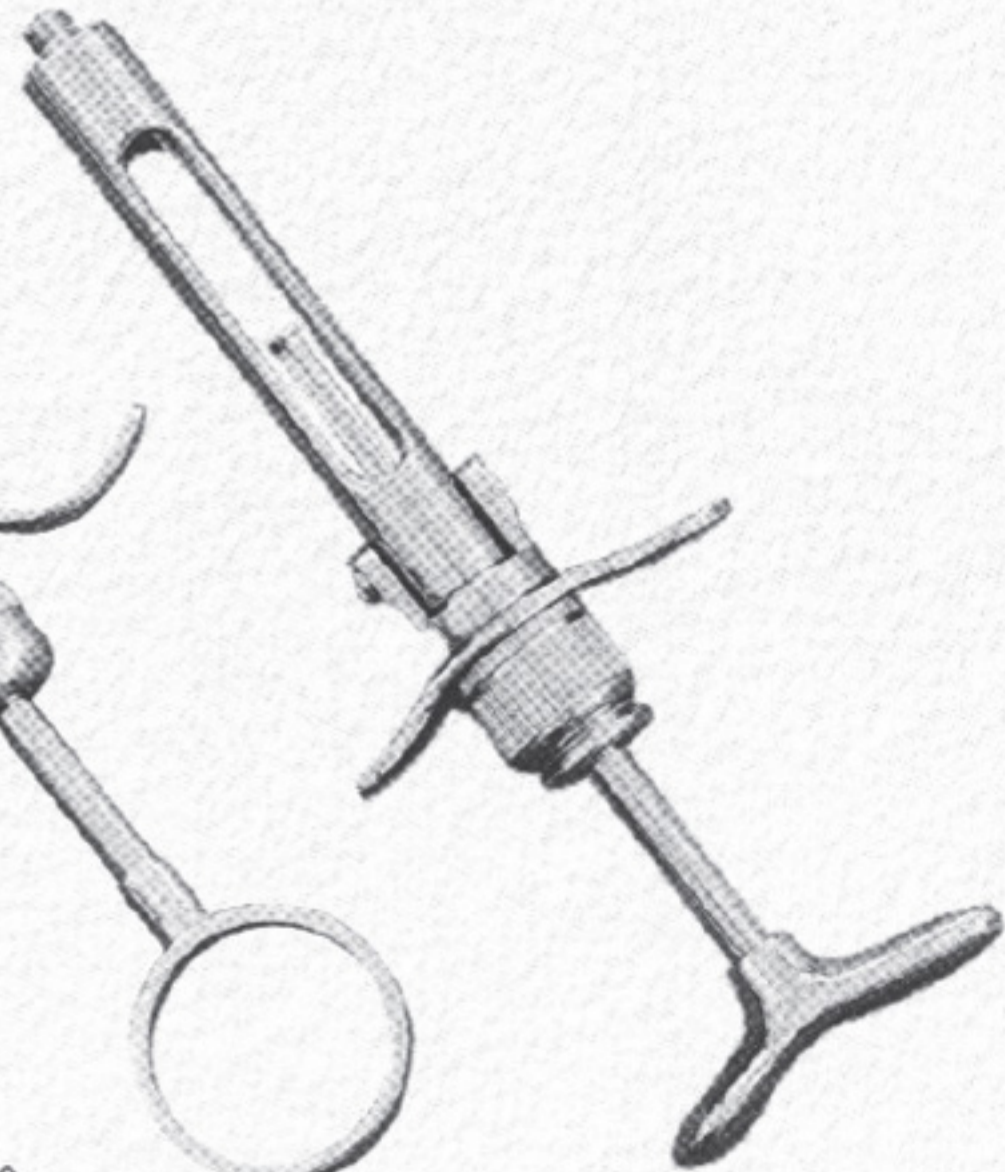

786-1041
Cartridge Syringe
1,8 ml



Chip Blowers, Water Syringes Napkin Holder, Film Holder

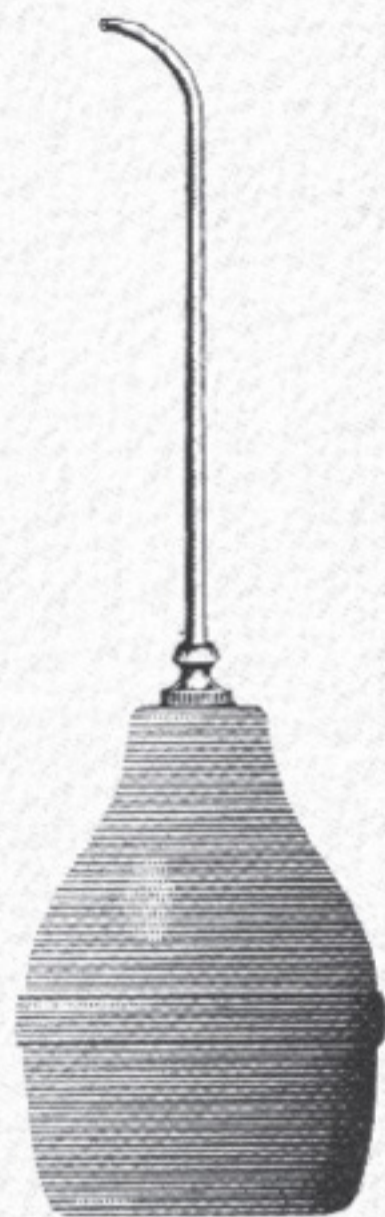

786-1042
Chip Blower



786-1043

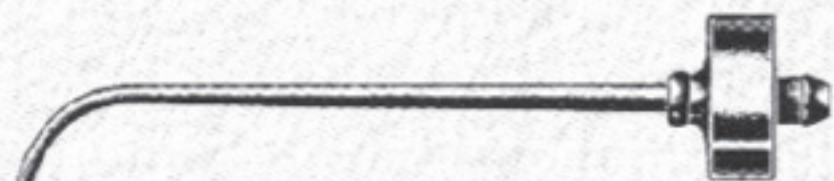

786-1044

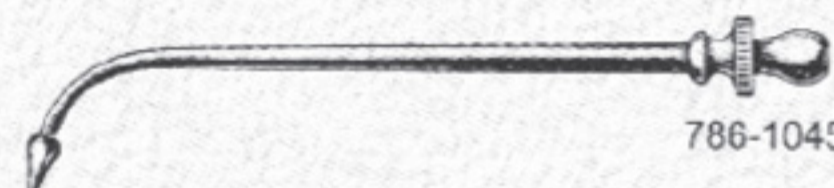

786-1045



786-1046
Film Holder for
10 films
786-1047
6 films
786-1048
14 films

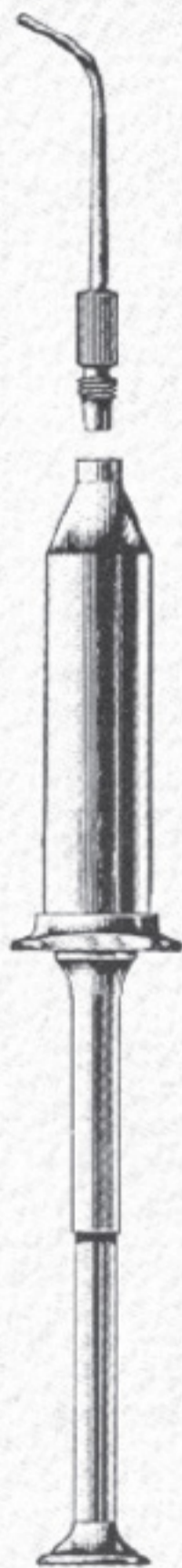

786-1049
Water Syringe

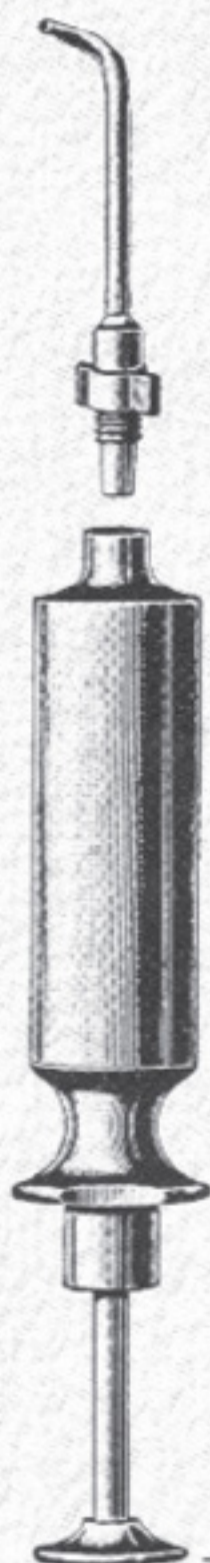

786-1050
Water Syringe

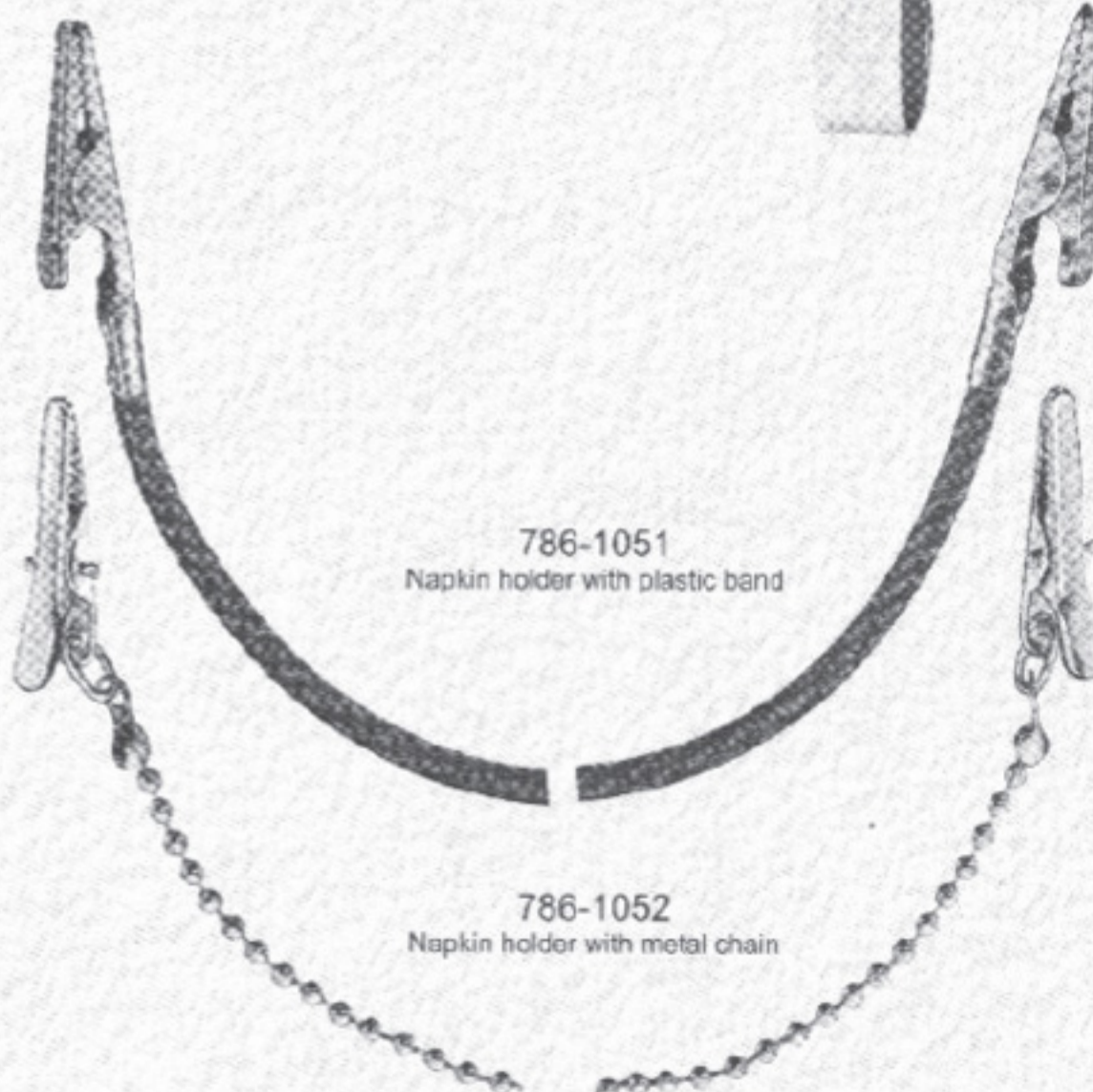

786-1051
Napkin holder with plastic band

786-1052
Napkin holder with metal chain



Matrix Retainers

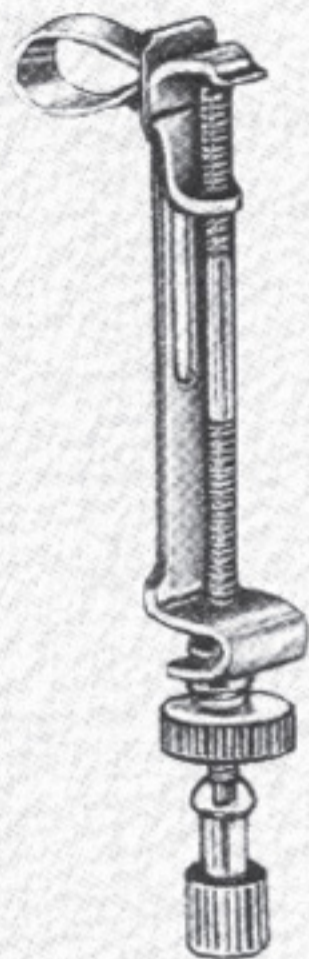

786-1053 - 5mm
786-1054 - 6mm
786-1055 - 7mm
Ivory 8

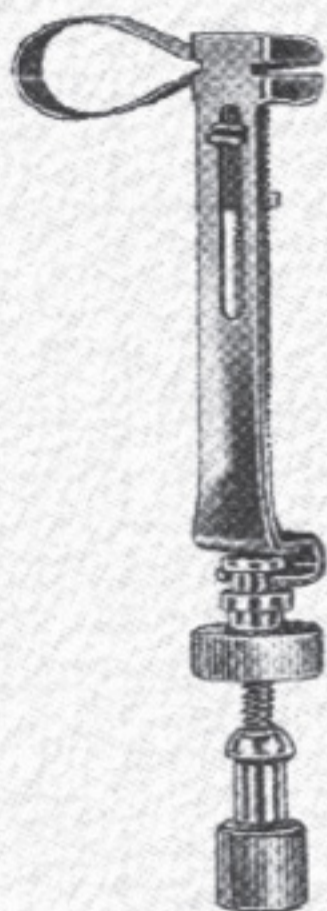

786-1056
Ivory 8 N



786-1057
Ivory 8



786-1058
Siqueland-Narrow
786-1059
Siqueland-Wide



786-1060
Fig. 1
Tofflemire-Universal

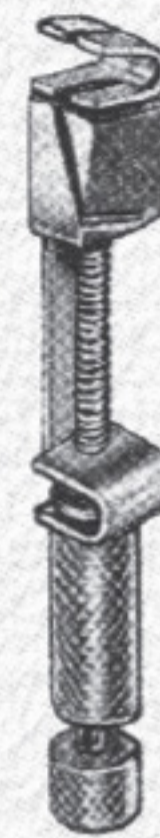

786-1061
Fig. 3
Tofflemire-Senior



786-1062
Fig. 2
Tofflemire-junior

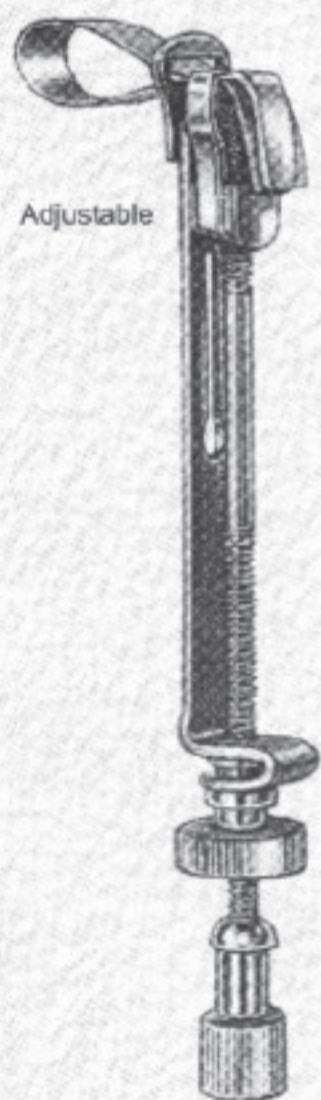

Adjustable

786-1063
Fig. 2
Didner 8P

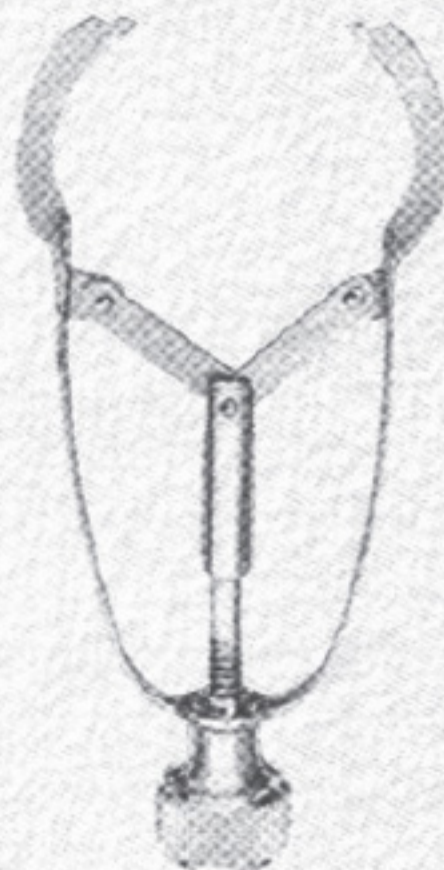

786-1064
Ivory

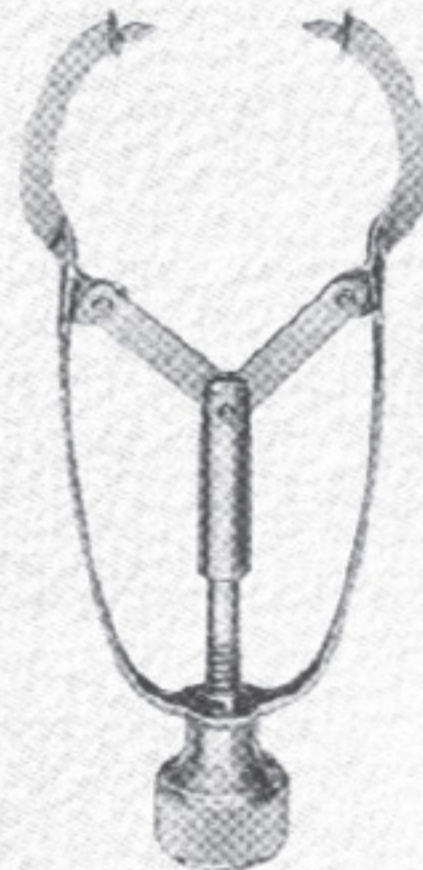

With lateral shields

786-1065
Ivory

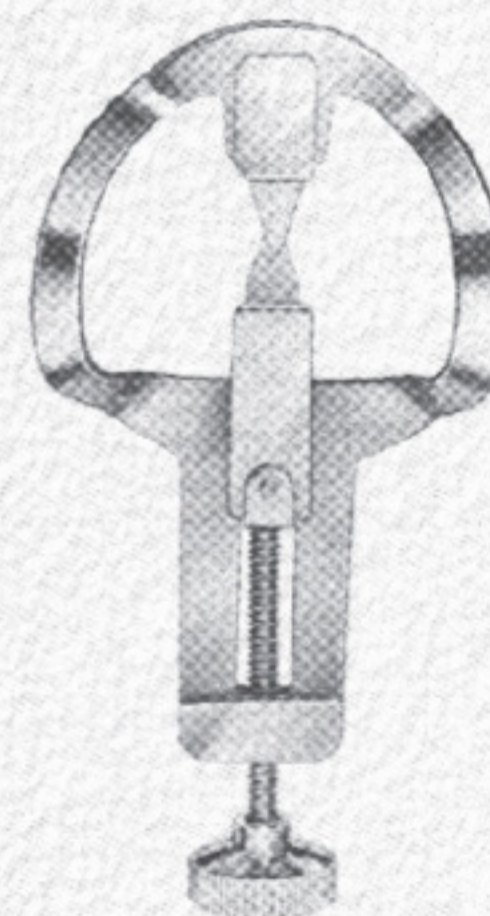

786-1066
Ivory
Separator



Crown Instruments

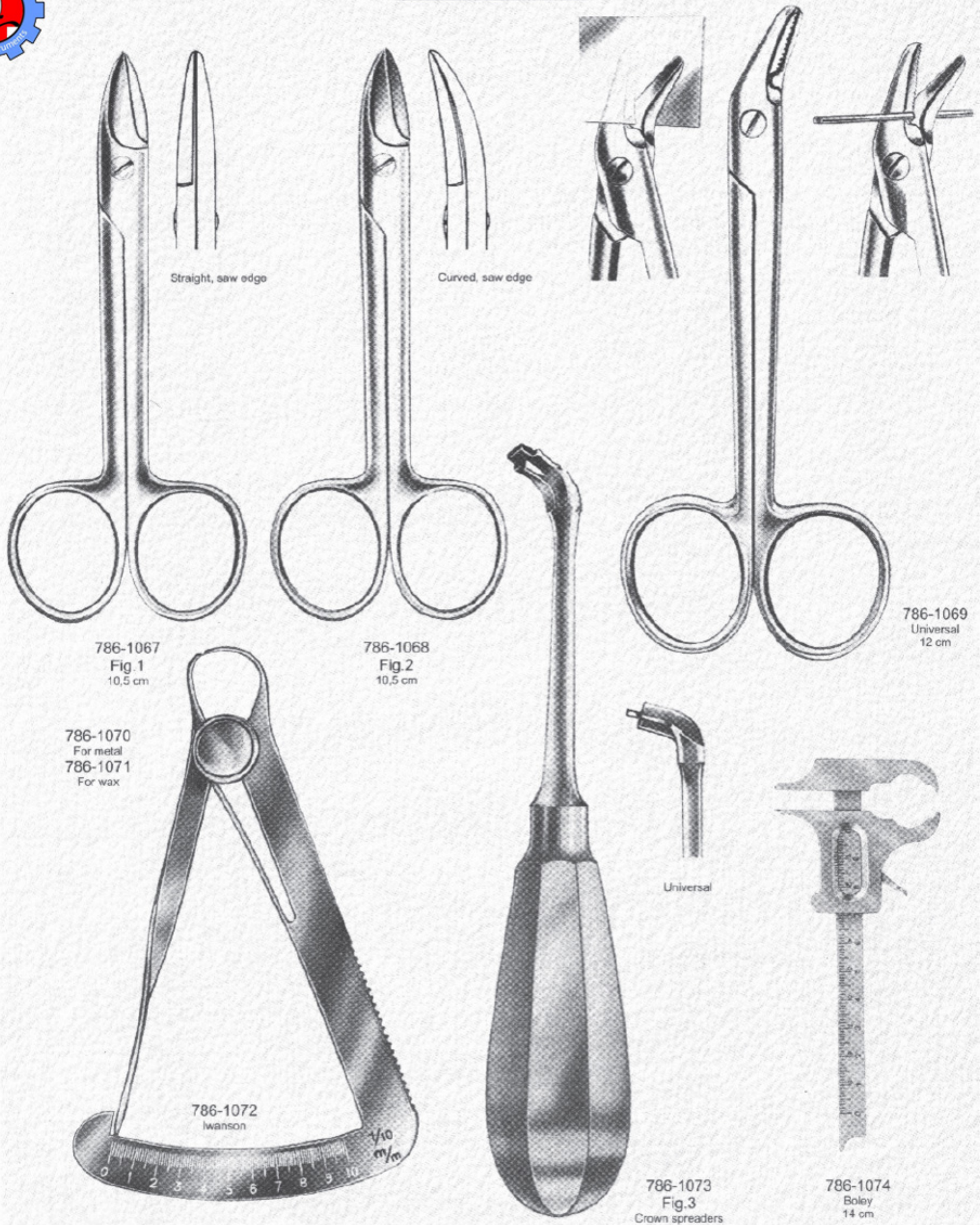



Crown Removers

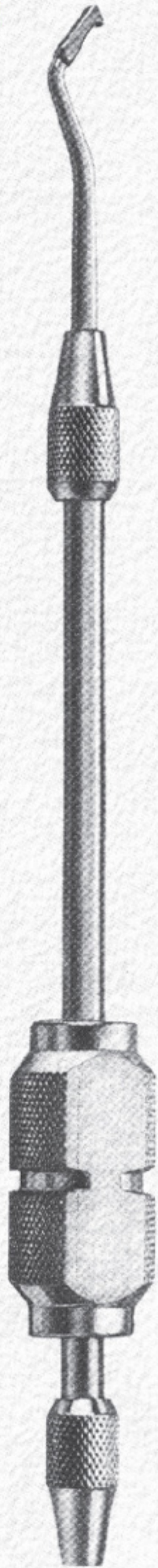

786-1076
Crown removers

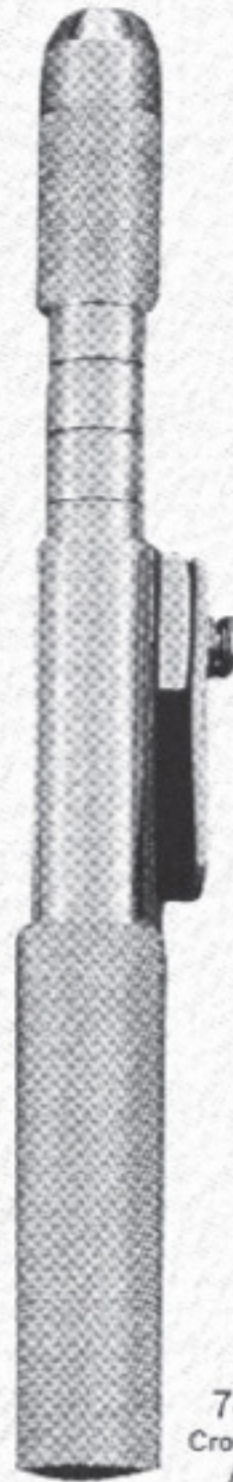
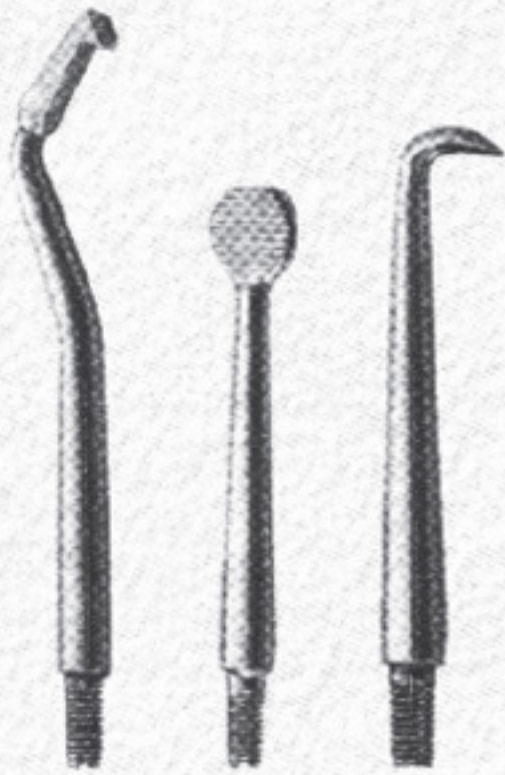

786-1075
Crown removers
Automatic

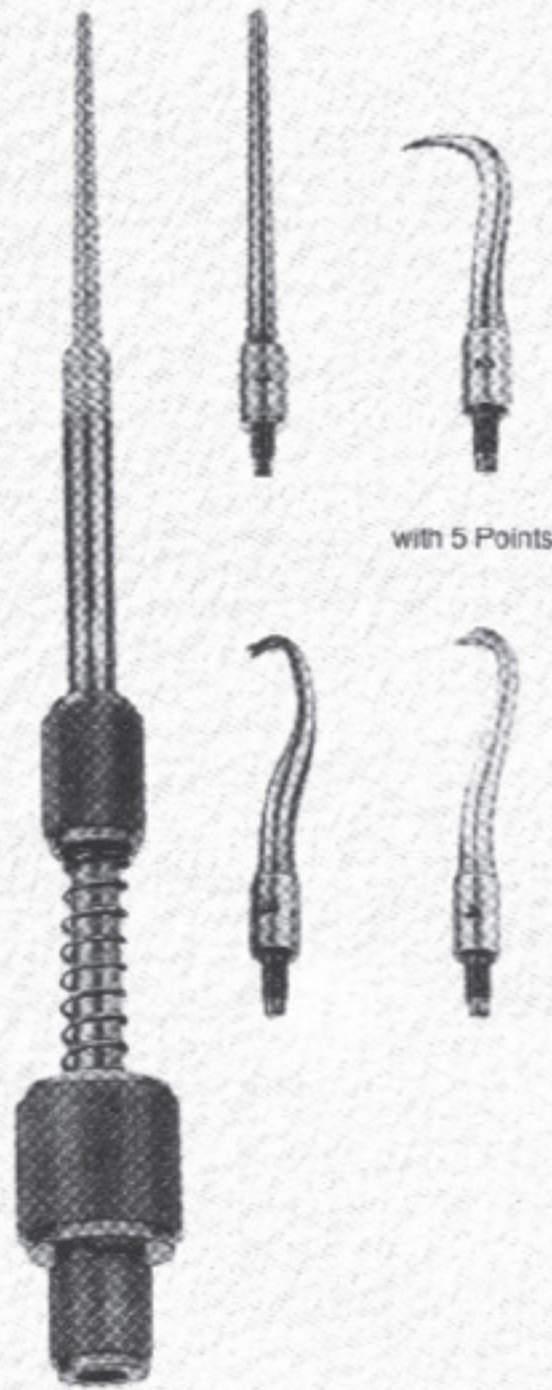
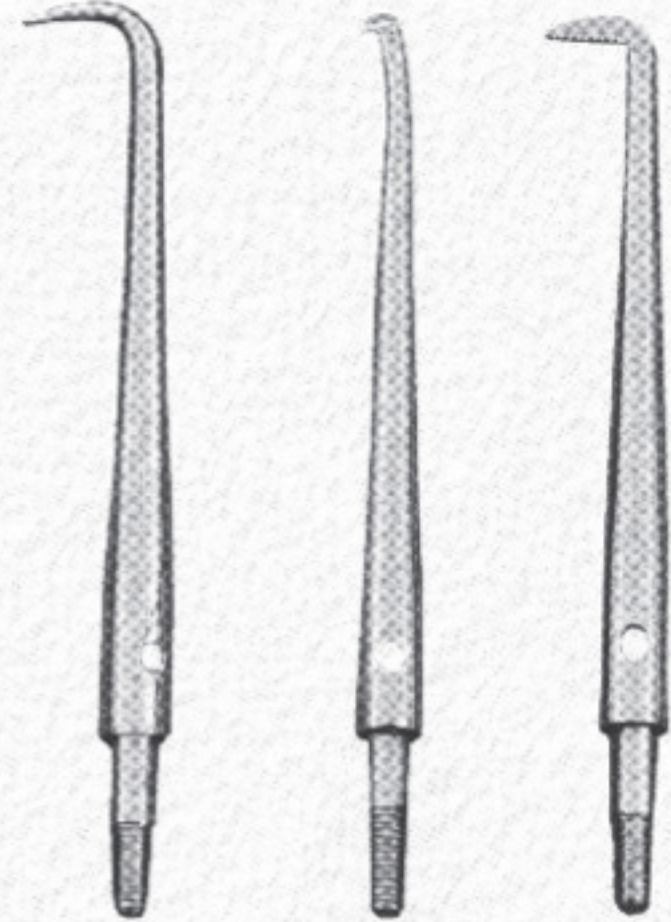

786-1077
Crown removers

with 5 Points

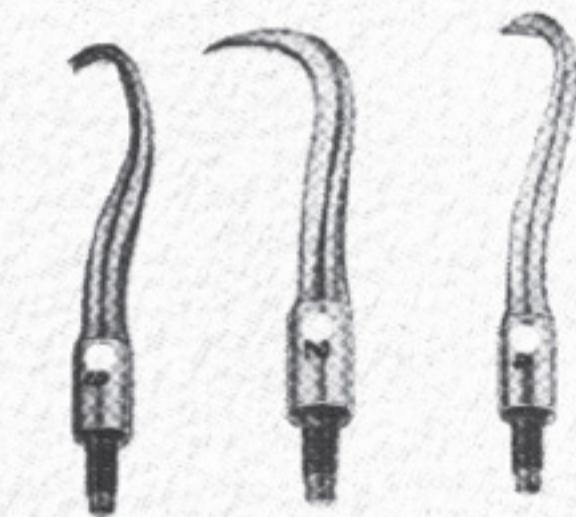
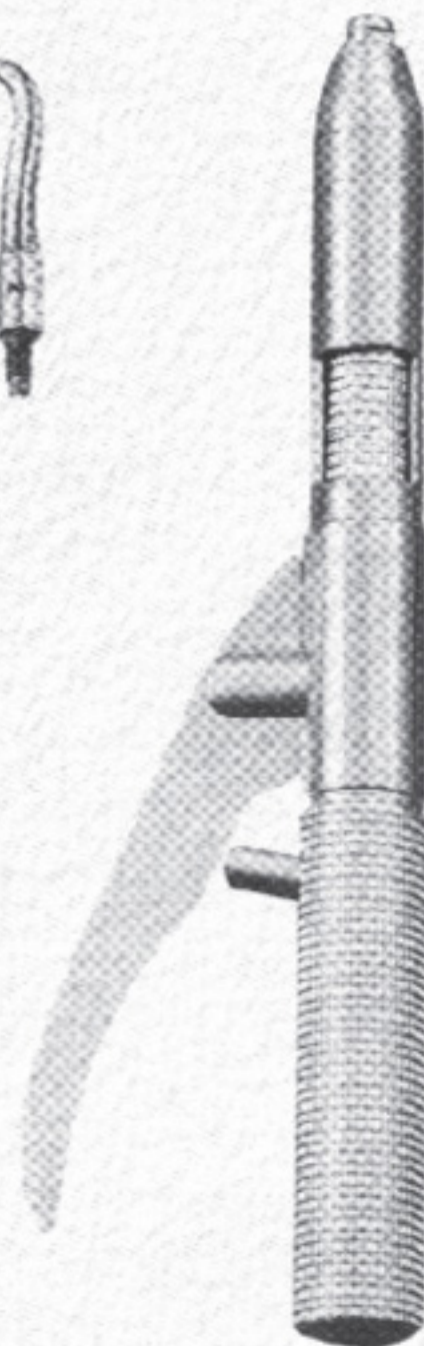

786-1078
Crown removers



Crown Instruments Plaster Cutting Plier

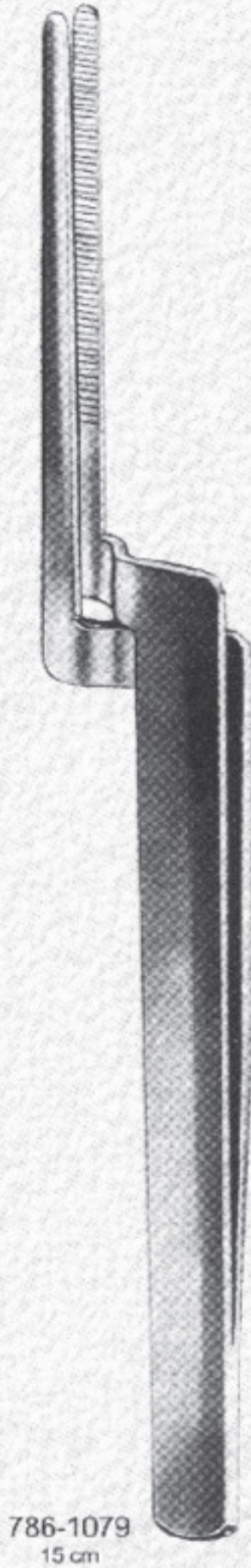

786-1079
15 cm

Articulating
paper forceps



786-1080
Miller
15 cm

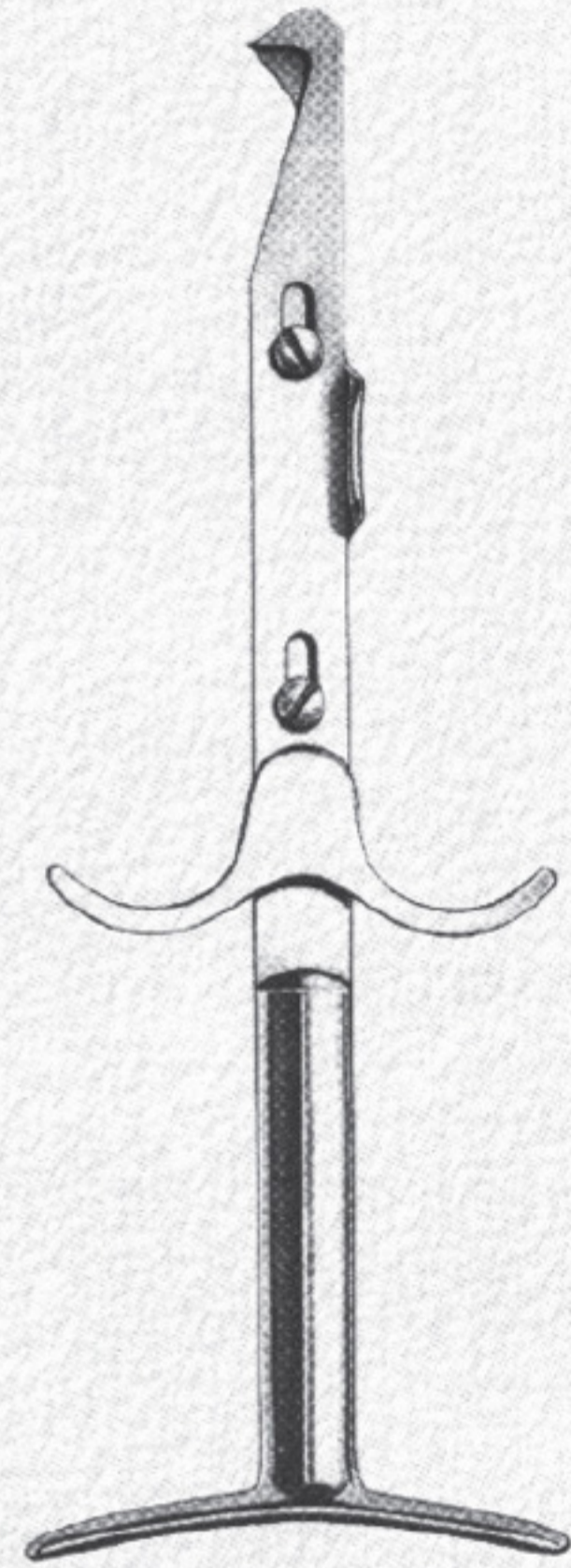

786-1081
Crown Spreader

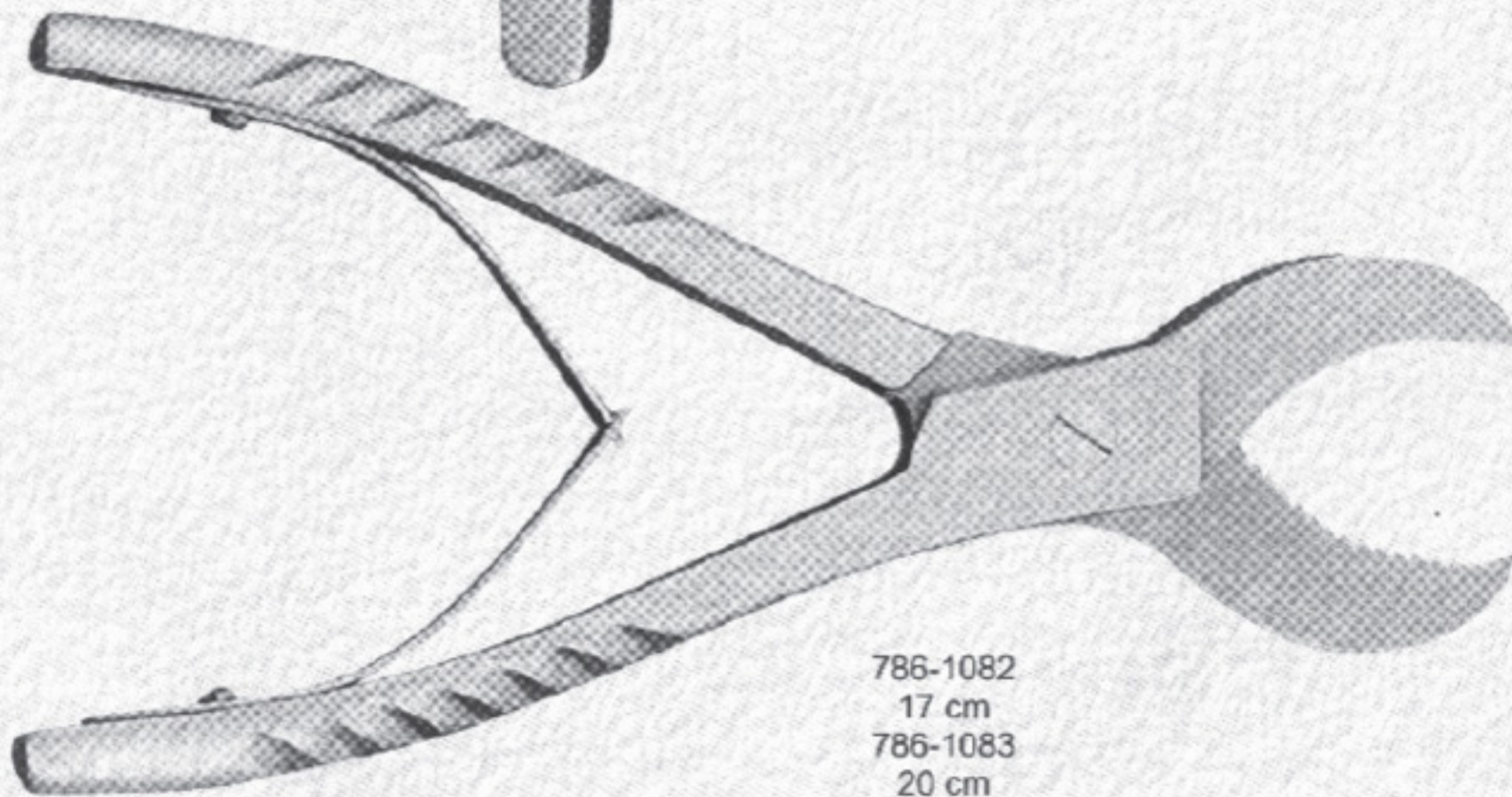

786-1082
17 cm
786-1083
20 cm
Plaster Cutting Plier



Stainless Steel Impression Trays Made of 18/8 Stainless Steel

**Solid Partial Set of 10
225-001S**

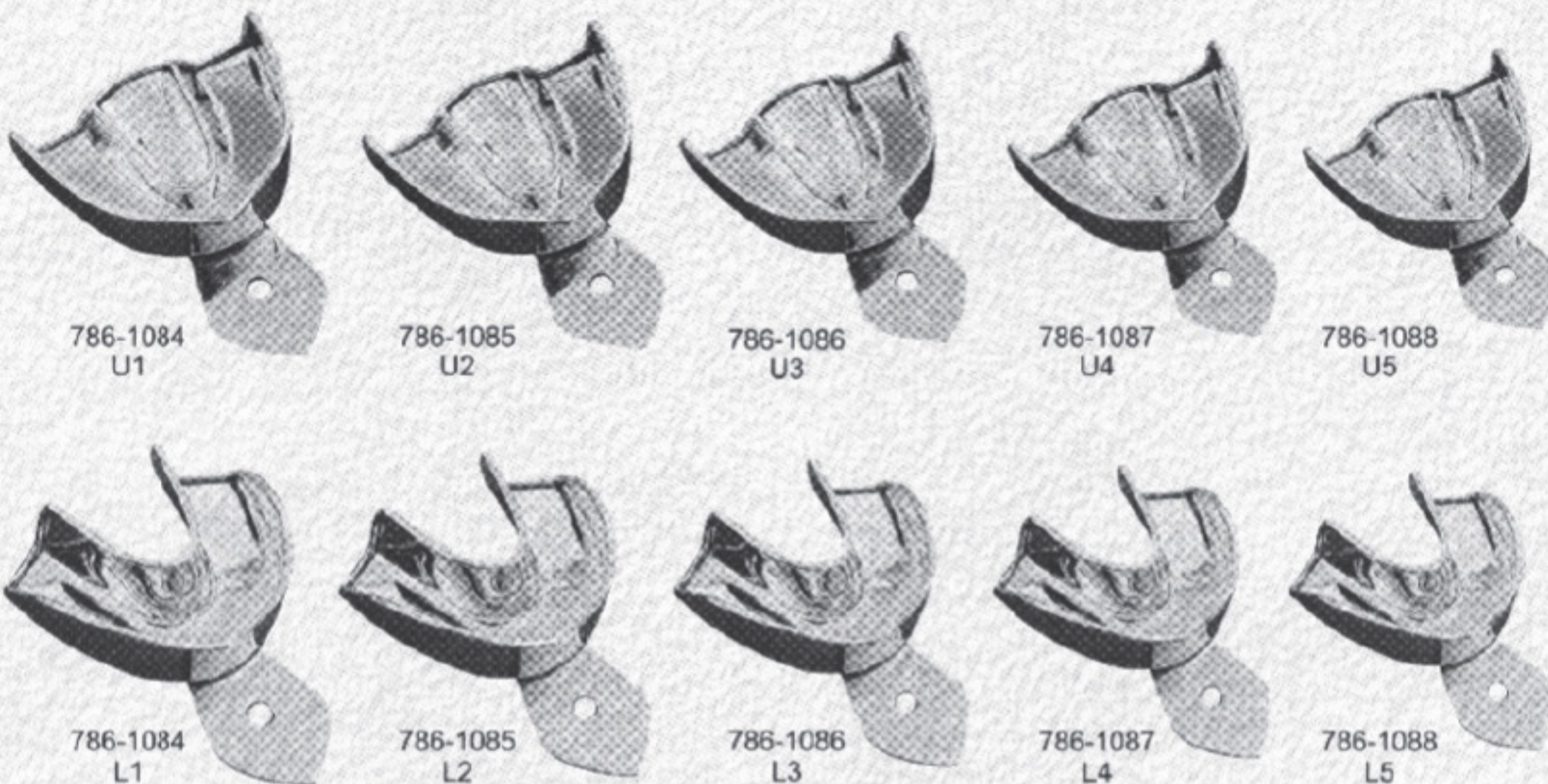

786-1084
U1

786-1085
U2

786-1086
U3

786-1087
U4

786-1088
U5

786-1084
L1

786-1085
L2

786-1086
L3

786-1087
L4

786-1088
L5

All the above impression trays are available in these 5 sizes

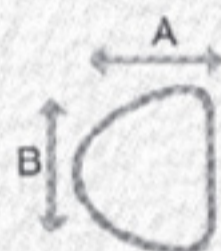

| UPPER | U1 | U2 | U3 | U4 | U5 |
|-------|----|----|----|----|----|
| | A | 62 | 60 | 53 | 54 |
| B | 83 | 75 | 73 | 69 | 68 |

All Dimension are in mm

| LOWER | L1 | L2 | L3 | L4 | L5 |
|-------|----|----|----|----|----|
| | A | 63 | 61 | 57 | 60 |
| B | 82 | 81 | 78 | 74 | 71 |

All Dimension are in mm

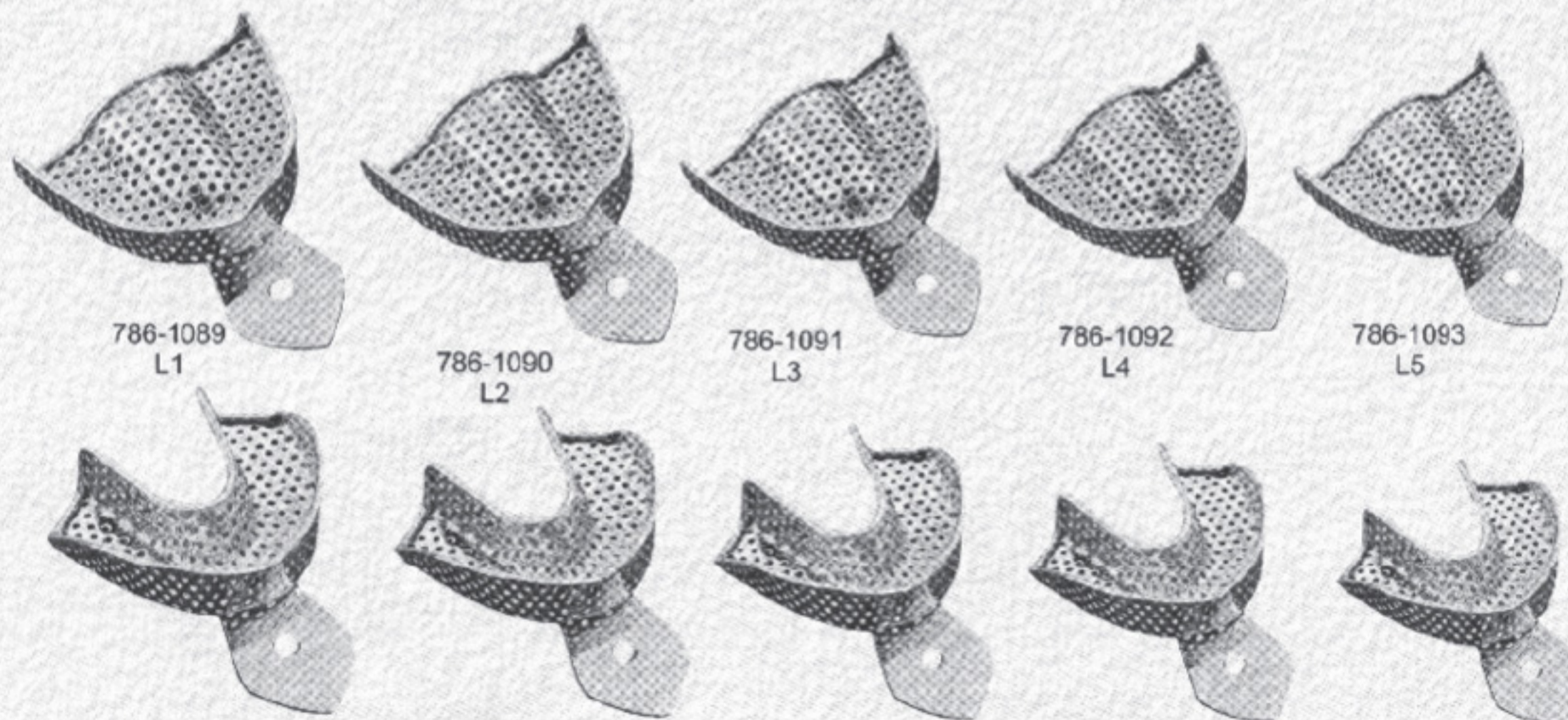
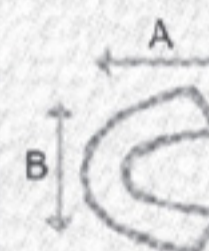

786-1089
L1

786-1090
L2

786-1091
L3

786-1092
L4

786-1093
L5

786-1089
U1

786-1090
U2

786-1091
U3

22786-1092
5-009
U4

786-1093
U5

**Perforated Partial Set of 10
225-010S**



Stainless Steel Impression Trays Made of 18/8 Stainless Steel

**Solid Full Denture Set of 8
225-011S**

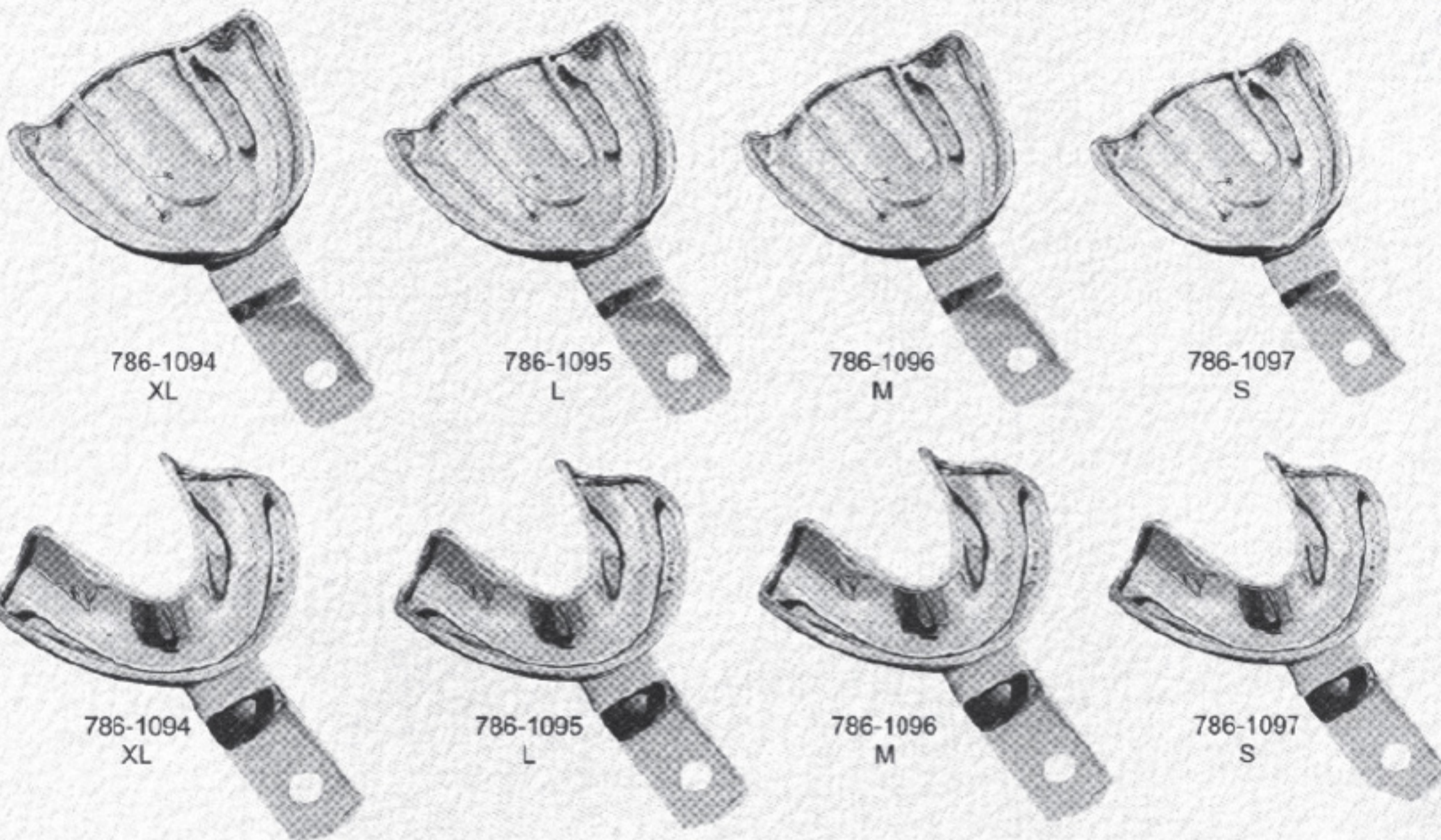

All the above impression trays are available in these 4 sizes

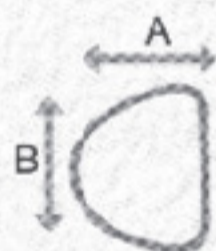

| UPPER | | XL | L | M | S |
|-------|----|----|----|----|----|
| | A | 70 | 67 | 64 | 60 |
| B | 79 | 76 | 70 | 73 | |

All Dimension are in mm

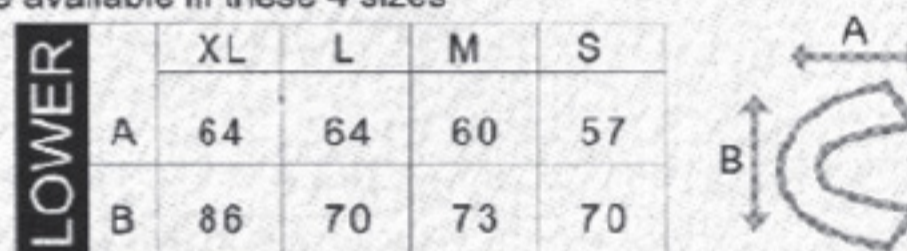

| LOWER | | XL | L | M | S |
|-------|----|----|----|----|----|
| | A | 64 | 64 | 60 | 57 |
| B | 86 | 70 | 73 | 70 | |

All Dimension are in mm

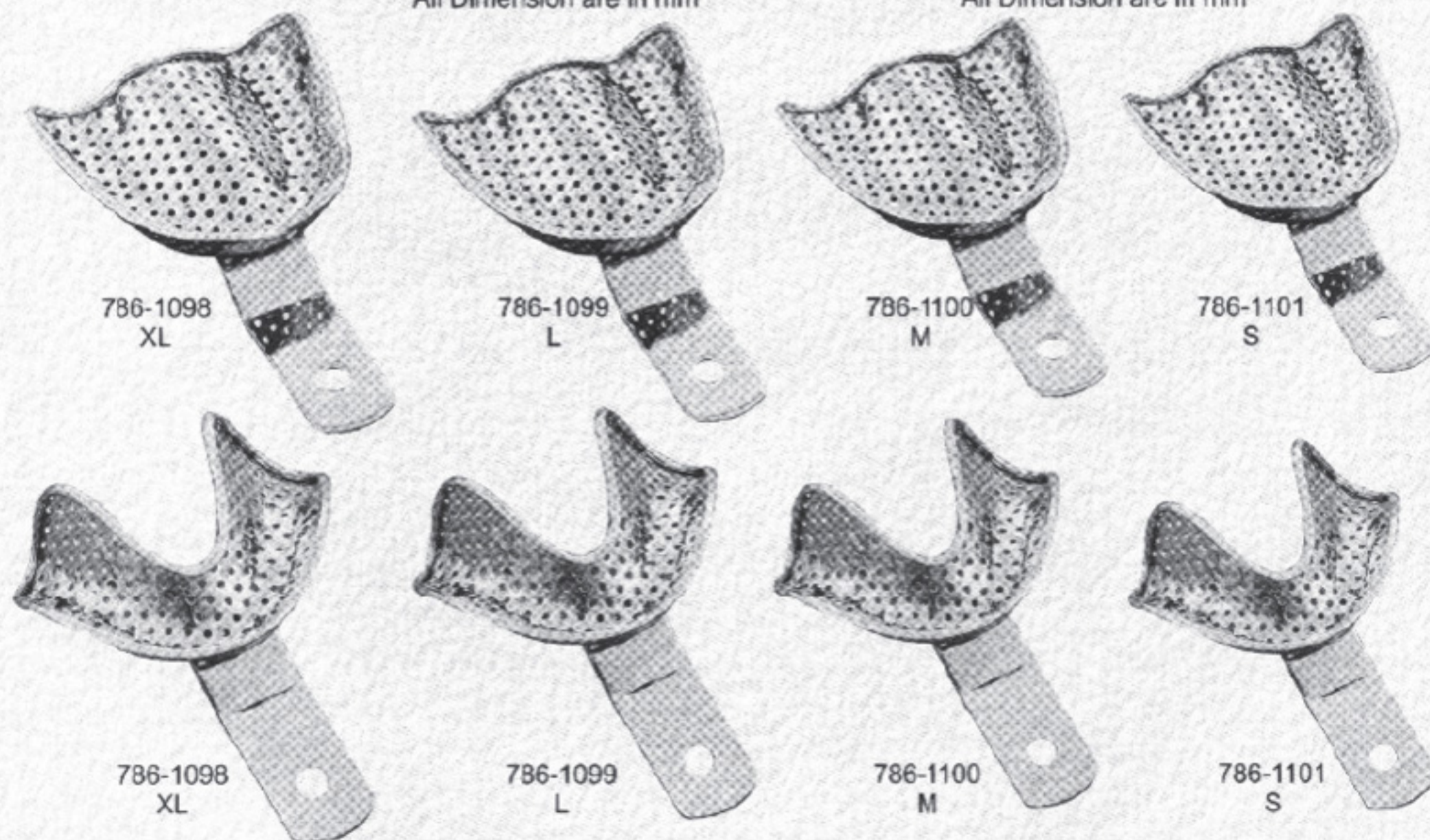

**Perforated Full Denture Set of 8
225-018S**



Stainless Steel Impression Trays Made of 18/8 Stainless Steel

**Solid Set of 6
225-019S**



786-1102
U1

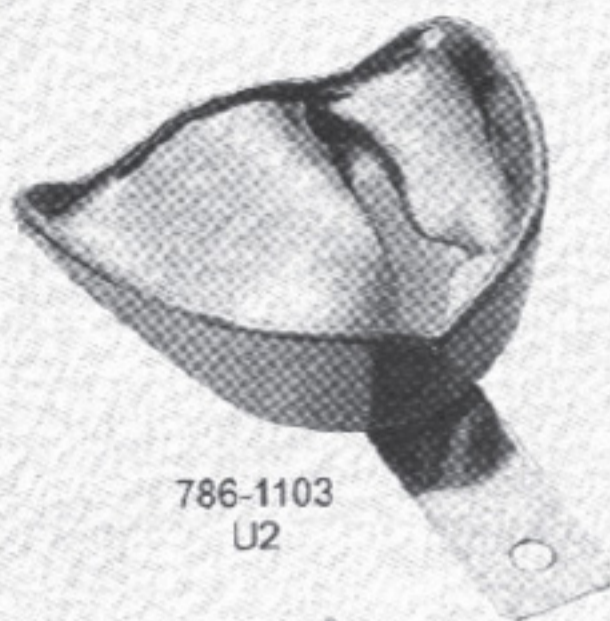

786-1103
U2

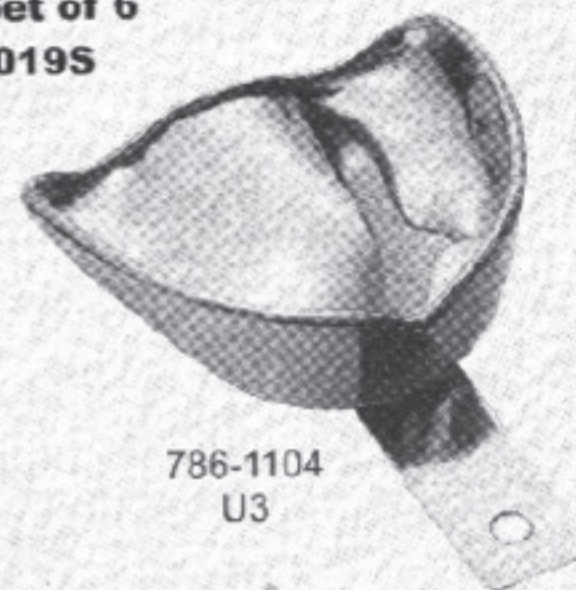

786-1104
U3

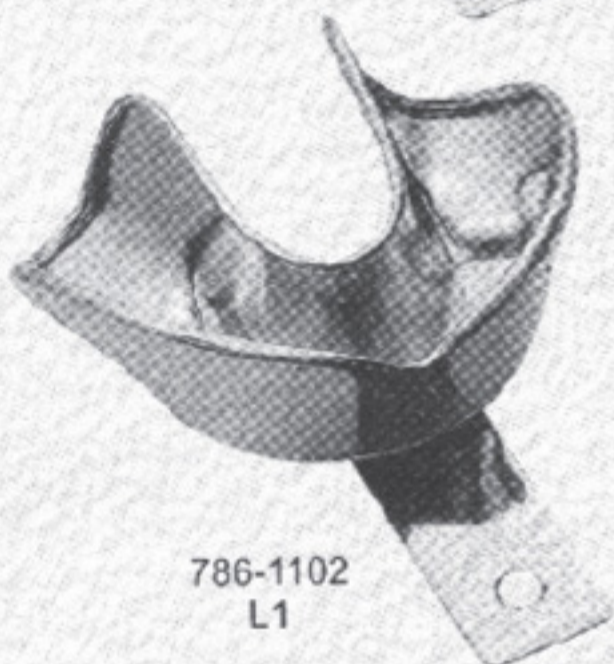

786-1102
L1

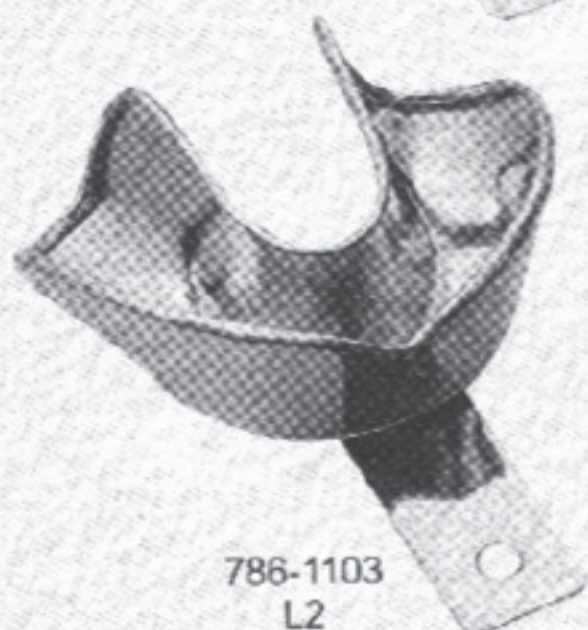

786-1103
L2

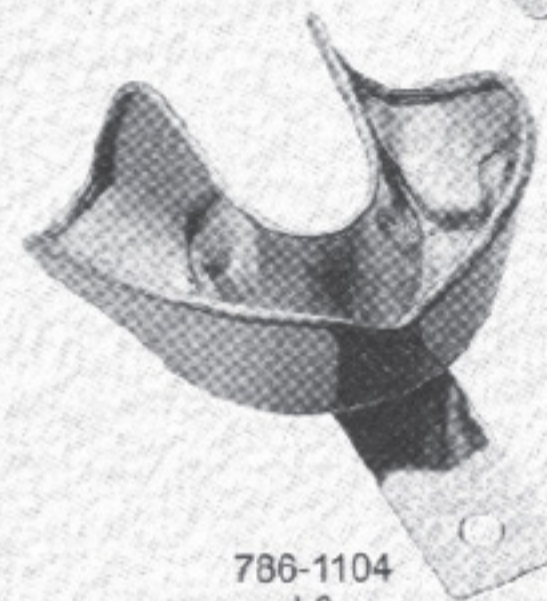

786-1104
L3

All the above impression trays are available in these 3 sizes

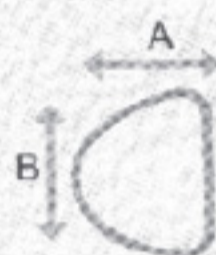

UPPER

| | U1 | U2 | U3 |
|---|----|----|----|
| A | 67 | 64 | 57 |
| B | 81 | 71 | 70 |

All Dimension are in mm

LOWER

| | L1 | L2 | L3 |
|---|----|----|----|
| A | 60 | 57 | 54 |
| B | 81 | 79 | 76 |

All Dimension are in mm

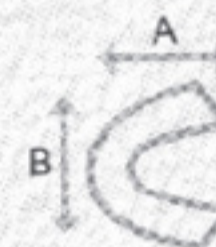

786-1105
U1

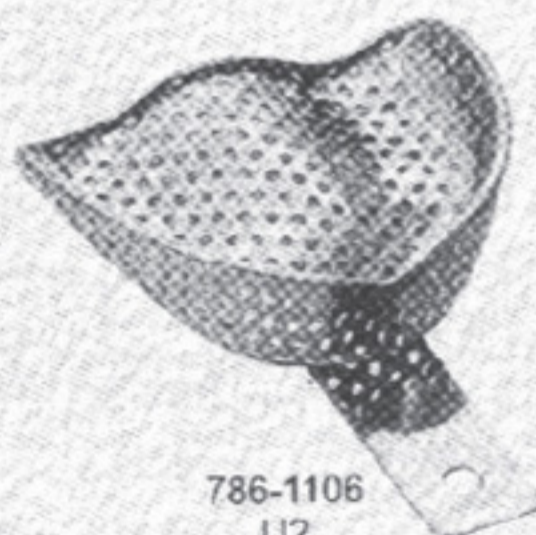

786-1106
U2



786-1107
U3



786-1105
L1



786-1106

**Perforated Set of 6 L2
225-024S**



786-1107
L3



Stainless Steel Impression Trays Made of 18/8 Stainless Steel

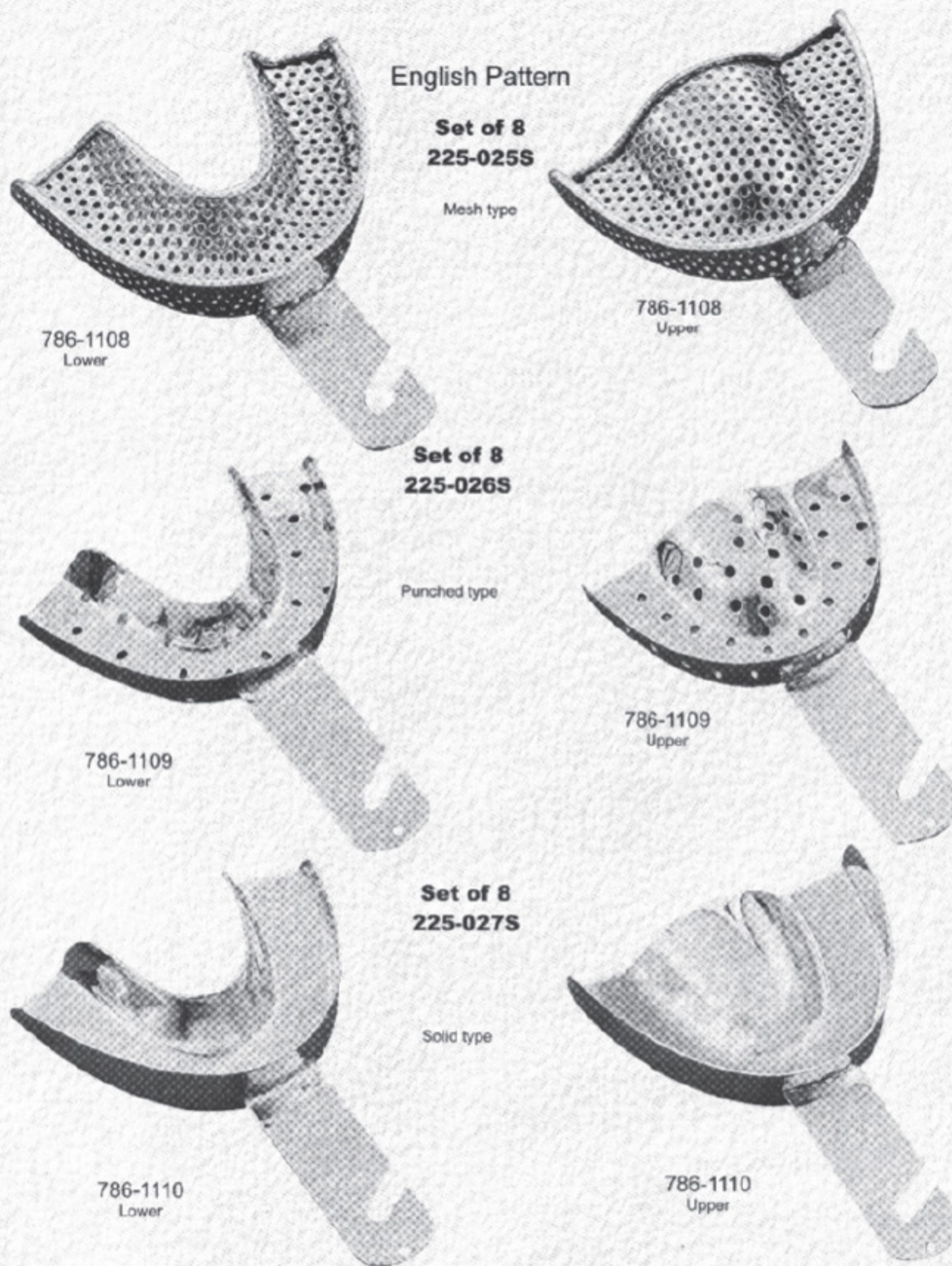

All the above impression trays are available in these 4 sizes

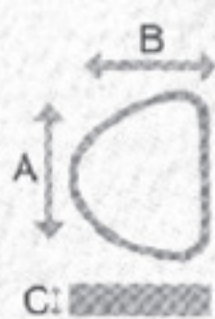

| UPPER | Size | A | B | C |
|-------|------|----|----|----|
| | 0 | 67 | 50 | 12 |
| | 1 | 72 | 51 | 13 |
| | 2 | 78 | 55 | 15 |
| | 3 | 80 | 58 | 15 |

All Dimension are in mm

| LOWER | Size | A | B | C |
|-------|------|----|----|----|
| | 0 | 70 | 50 | 14 |
| | 1 | 77 | 51 | 15 |
| | 2 | 79 | 55 | 15 |
| | 3 | 80 | 60 | 17 |

All Dimension are in mm

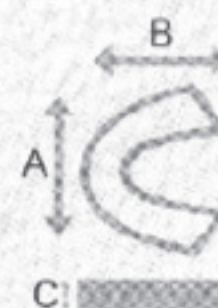



Stainless Steel Impression Trays Made of 18/8 Stainless Steel

**Solid Full Denture Set of 8
225-028S**



786-1111
XL



786-1112
L



786-1113
M

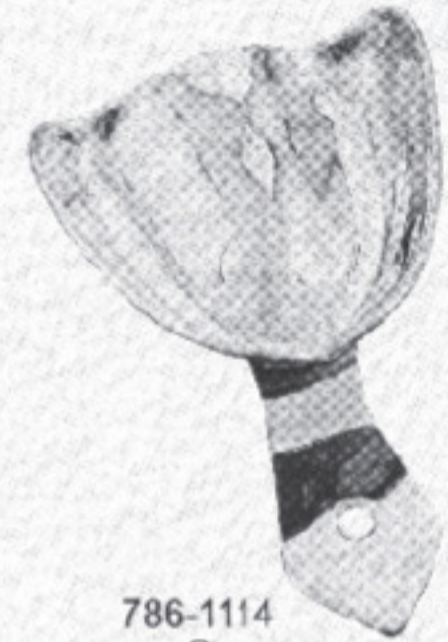

786-1114
S

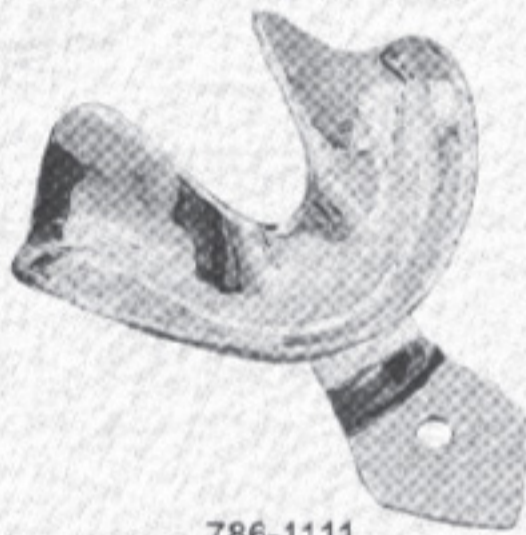

786-1111
XL



786-1112
L



786-1113
M



786-1114
S

All the above impression trays are available in these 4 sizes

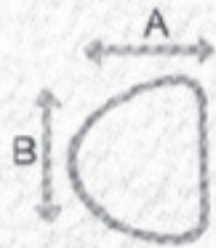

| UPPER | | XL | L | M | S |
|-------|----|----|----|----|----|
| | A | 70 | 67 | 64 | 60 |
| B | 79 | 76 | 70 | 73 | |

All Dimension are in mm

| LOWER | | XL | L | M | S |
|-------|----|----|----|----|----|
| | A | 64 | 64 | 60 | 57 |
| B | 86 | 70 | 73 | 70 | |

All Dimension are in mm

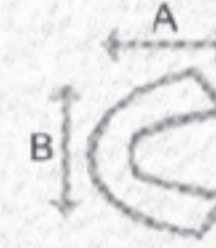

786-1115
XL



786-1116
L



786-1117
M

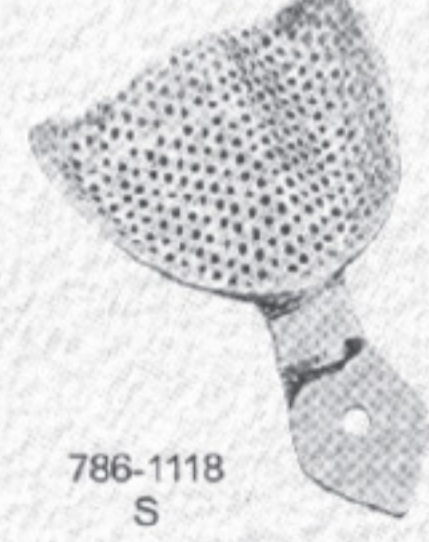

786-1118
S

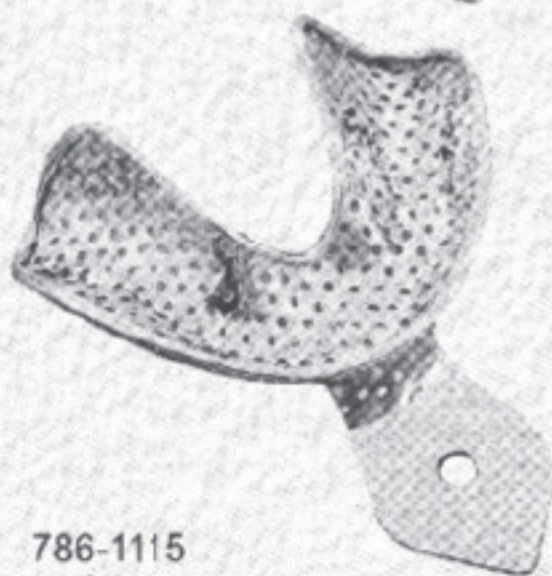

786-1115
XL



786-1116
L



786-1117
M

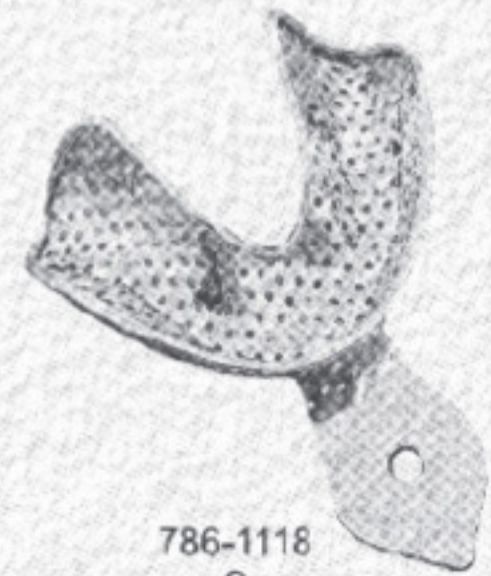

786-1118
S

**Perforated Full Denture Set of 8
225-035S**



Stainless Steel Impression Trays Made of 18/8 Stainless Steel



786-1119
U0

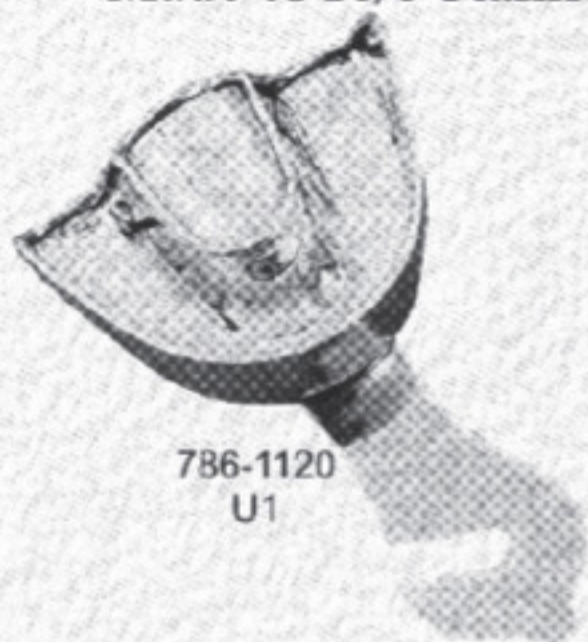

786-1120
U1

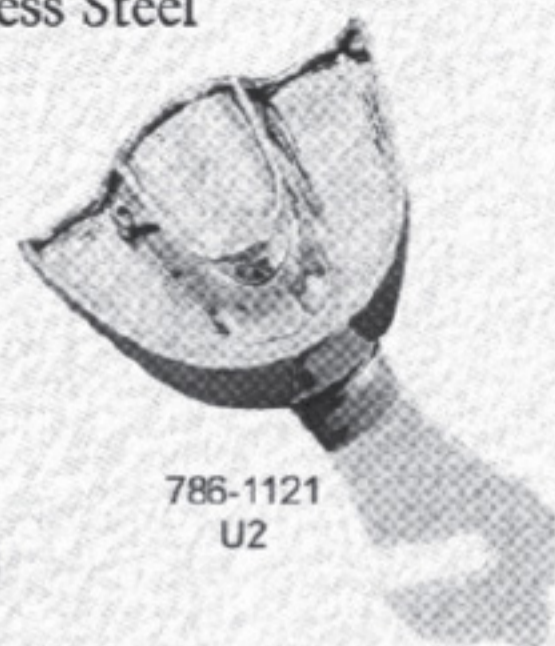

786-1121
U2



786-1122
U3



786-1119
L0

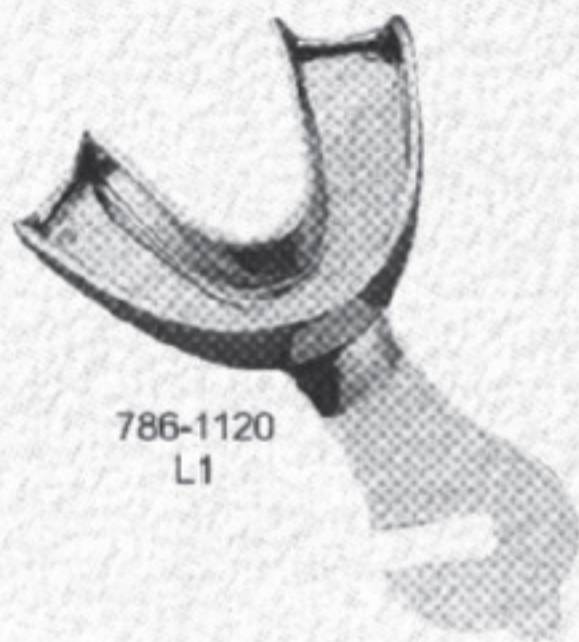

786-1120
L1



786-1121
L2



786-1122
L3

Upper Sizes 0,1,2,3,
Depth of the tray 15,9 mm
Height of palate 12,5 mm

Lower Sizes 0,1,2,3,
Depth of the tray 12,9 mm



786-1123
U0

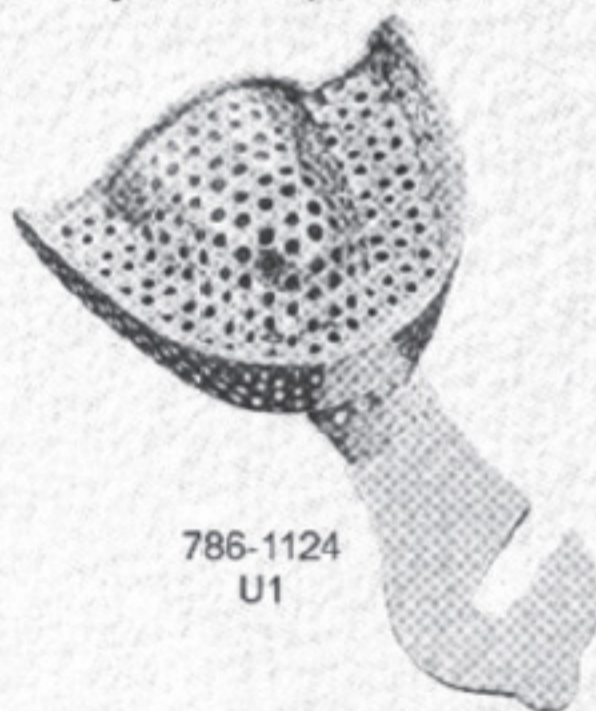

786-1124
U1



786-1125
U2



786-1126
U3



786-1123
L0



786-1124
L1



786-1125
L2



786-1126
L3

Perforated Full Denture Set of 8
225-043S



Stainless Steel Impression Trays Made of 18/8 Stainless Steel

Impression trays for crown & bridge work



786-1127
U1P



Solid

786-1127
L1P



786-1128
U1P



Perforated

786-1128
L1P



786-1129
For upper right jaw
For lower left jaw

Perforated

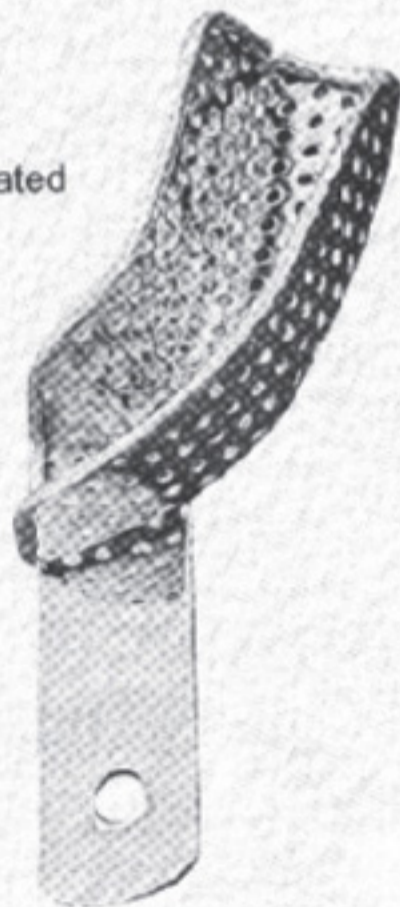

786-1130
For upper left jaw
For lower right jaw



786-1131
Adjustable
Perforated



786-1131A
Adjustable
Solid

Available in 4 Sizes

- 1..... 44 mm
- 2.....55 mm
- 3.....60 mm
- 4.....65 mm

Also available in Solid pattern



Stainless Steel Instrument Trays

Made of 18/8 Stainless Steel

786-1132S

Complete instrument tray with perforated base, lid & insert frame for 16 instrument



786-1132

Lid; dimensions mm, 288x187x29

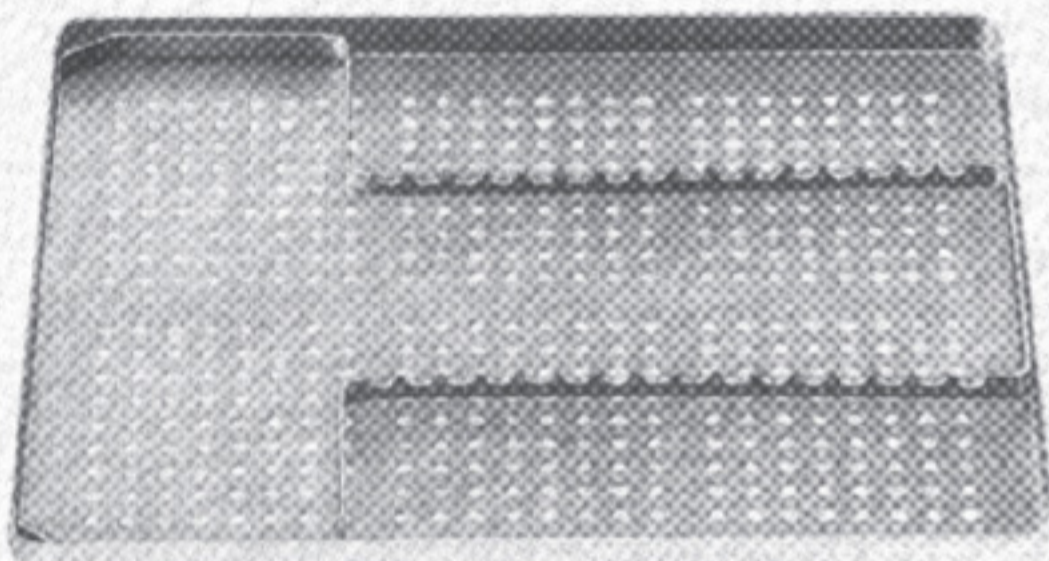

786-1133

Perforated base; dimensions 284x183x17 mm

786-1125S

Complete instrument tray with solid base, lid & insert frame for 16 instrument



786-1134

Lid; dimensions 288x187x29 mm

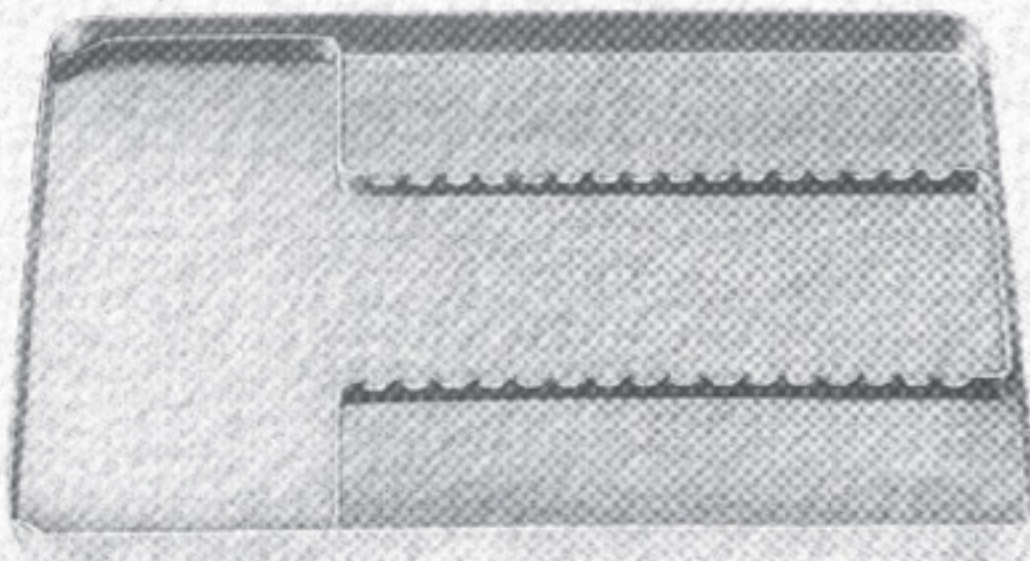

786-1135

Solid base; dimensions 284x183x17 mm

786-1137S

Complete instrument tray with perforated base, lid & insert frame for 23 instrument



786-1136

Lid; dimensions mm, 288x187x29

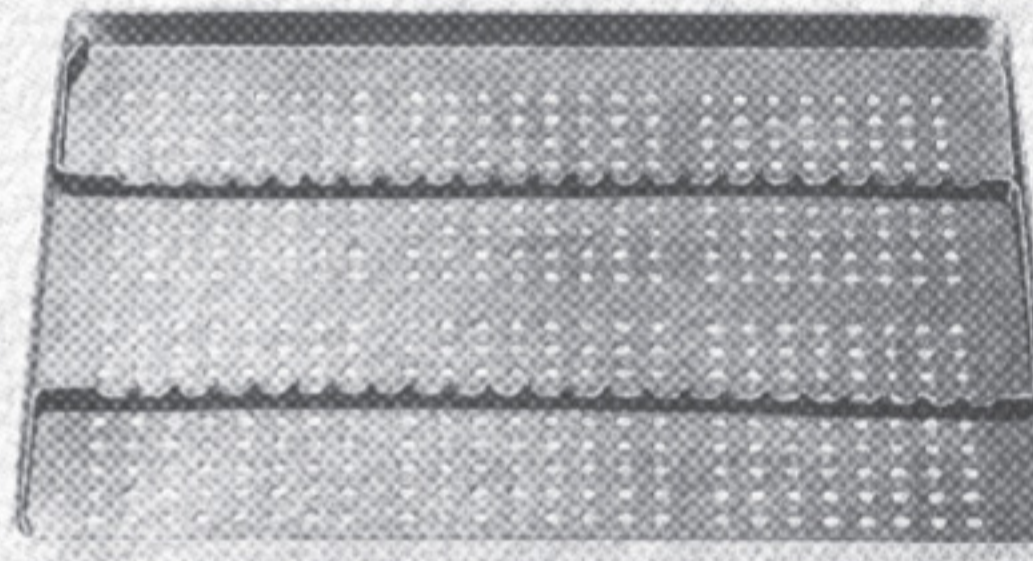

786-1137

Perforated base; dimensions 284x183x17 mm

786-1139S

Complete instrument tray with solid base, lid & insert frame for 23 instrument



786-1138

Lid; dimensions 288x187x29 mm

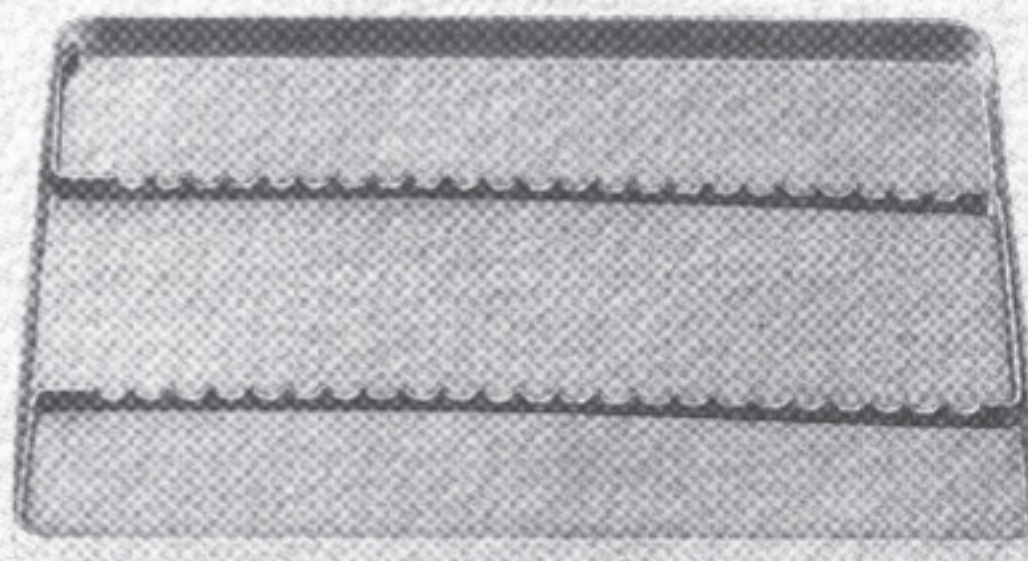

786-1139

Solid base; dimensions 284x183x17 mm



Stainless Steel Impression Trays Made of 18/8 Stainless Steel

Scalers Tray

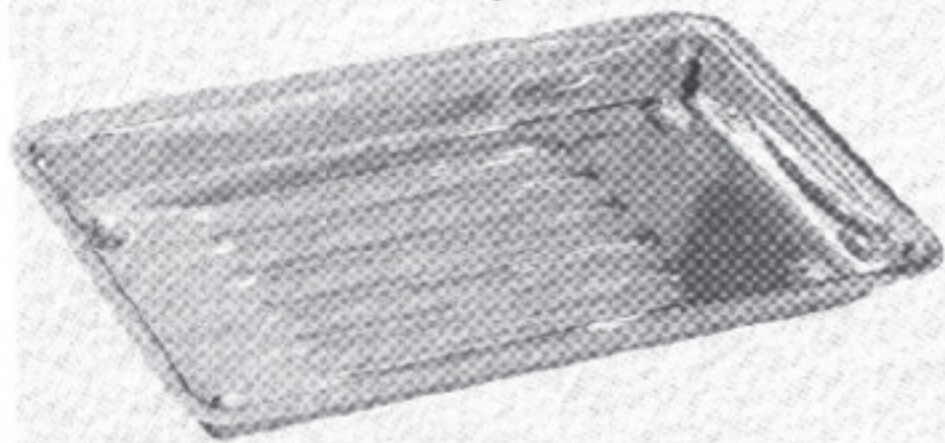

786-1140

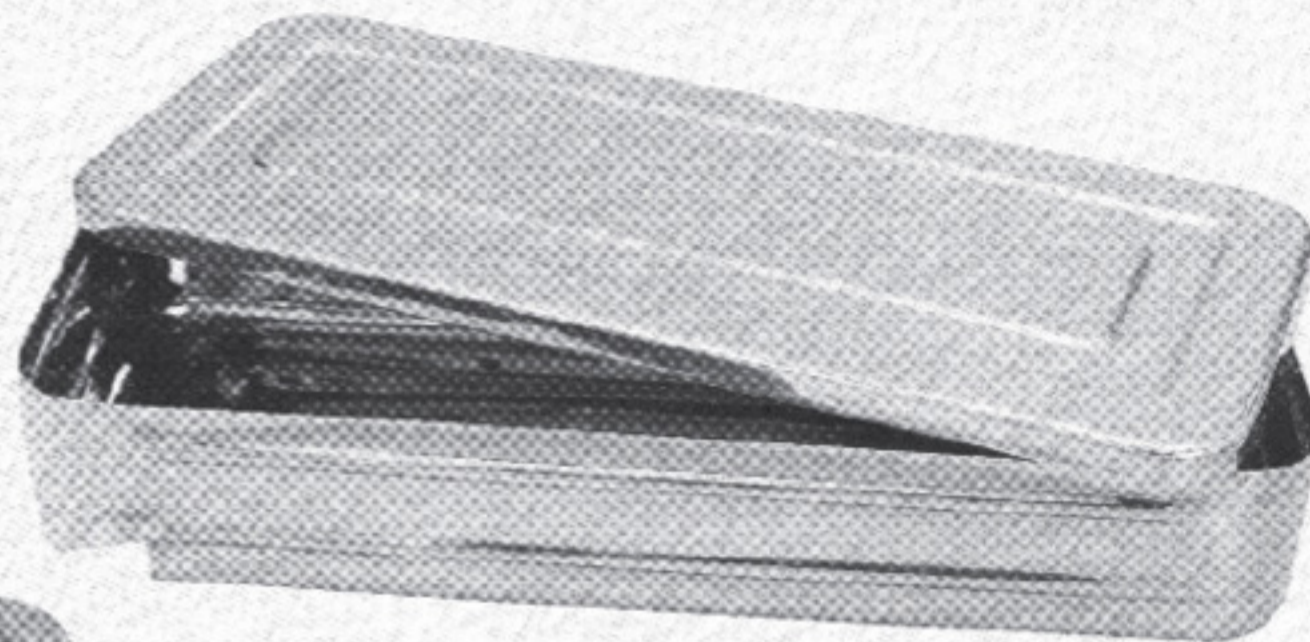

786-1141
6" x 10"
without lid

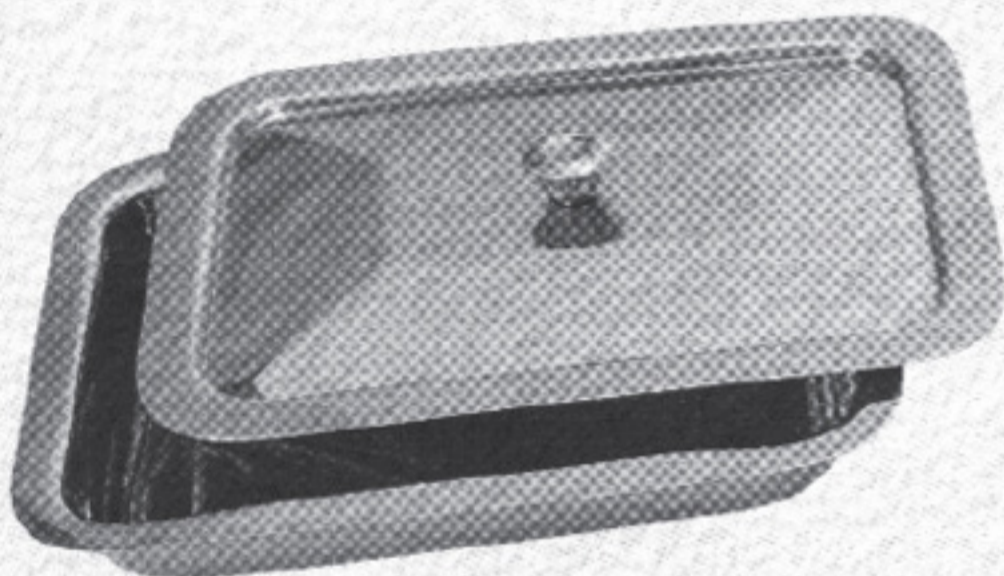

786-1142
6" x 8"
with lid



786-1143
6" x 8"
8" x 10"
10" x 12"
with lid

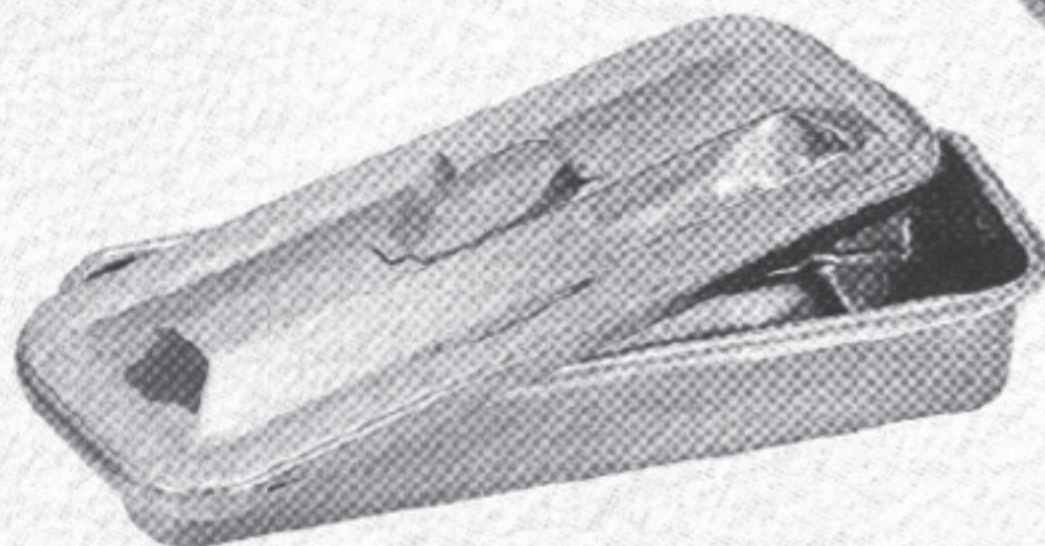

786-1144

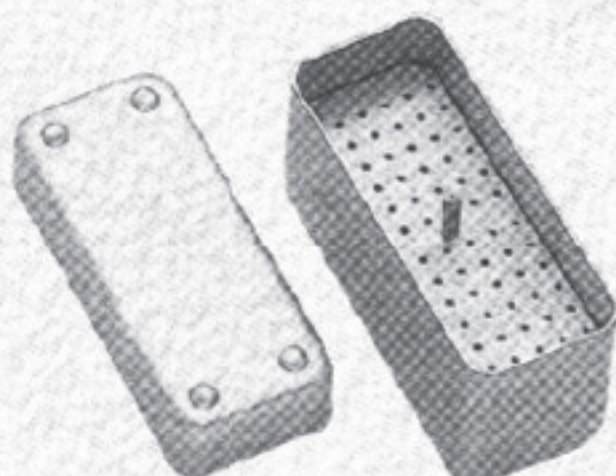

786-1145
Endodontic box
Also available in Solid pattern

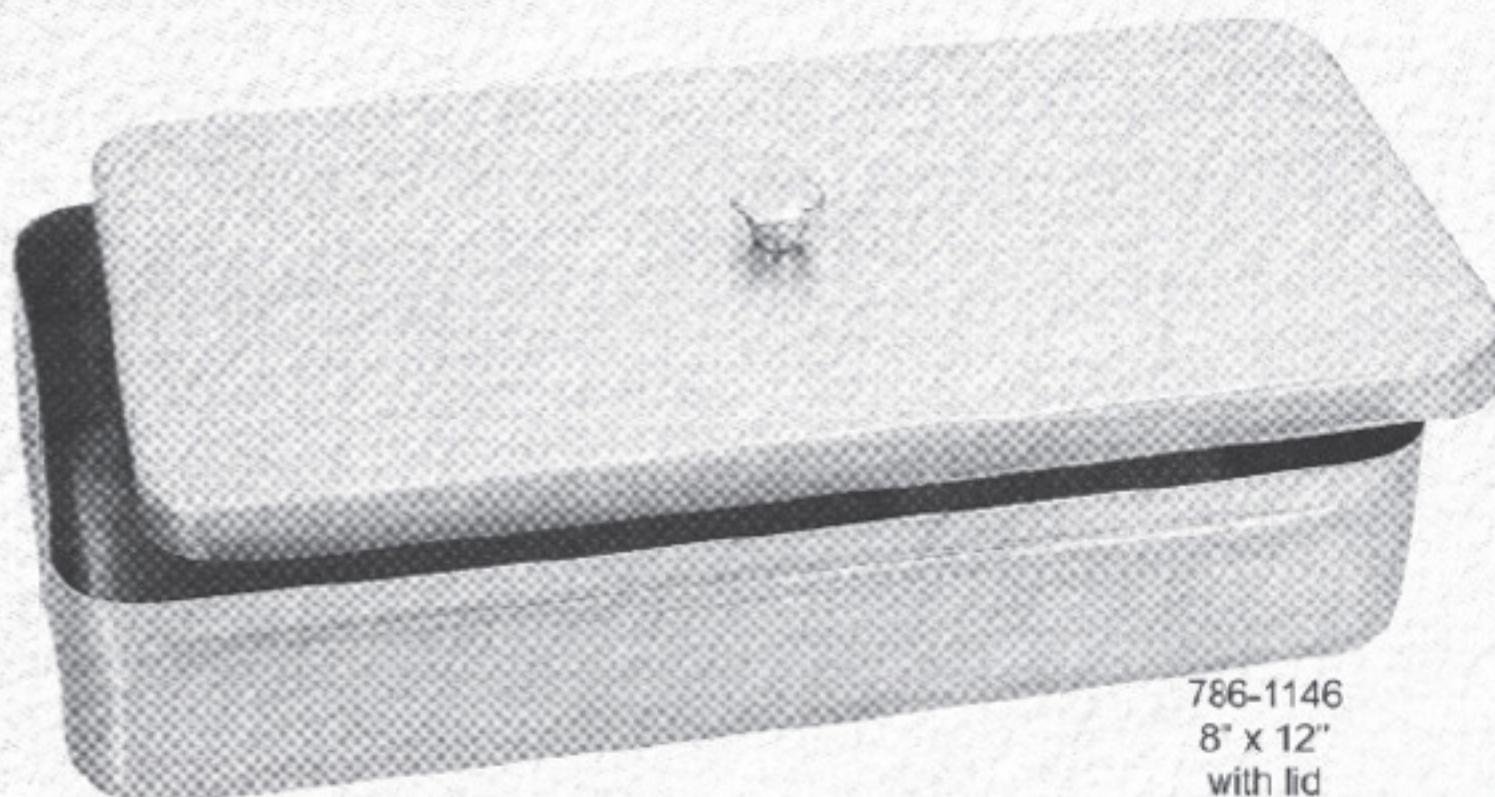

786-1146
8" x 12"
with lid



Stainless Steel Instrument Trays Made of 18/8 Stainless Steel

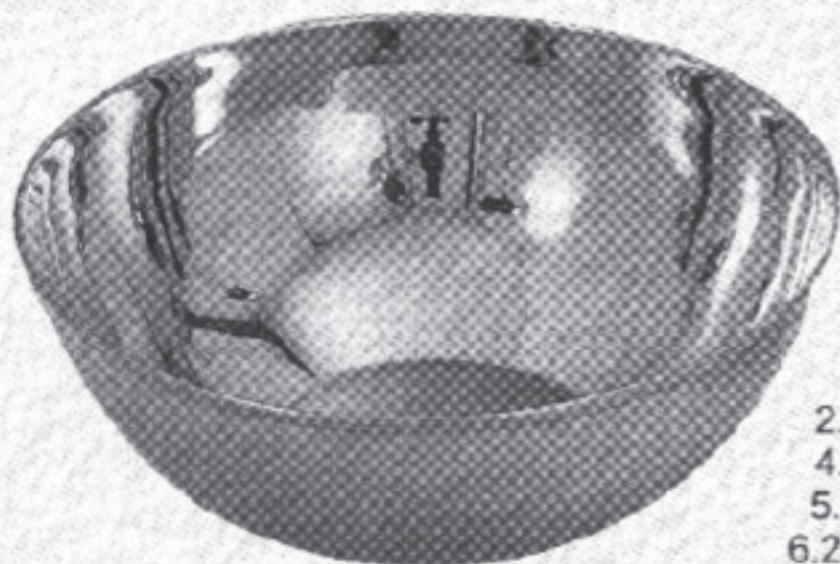

786-1147

Deep

2.25" x 2"
4.75" x 2"
5.5" x 2.5"
6.25" x 2.75"
7" x 3.5"

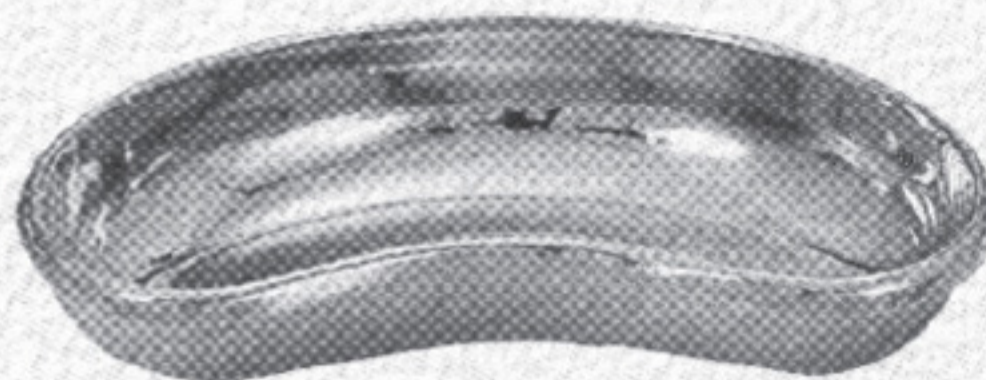

Kidney trays

786-1148
12"-10"- 8"- 6"



786-1149
6" x 9" - 8" x 12"



Shallow

786-1150
10" x 10"

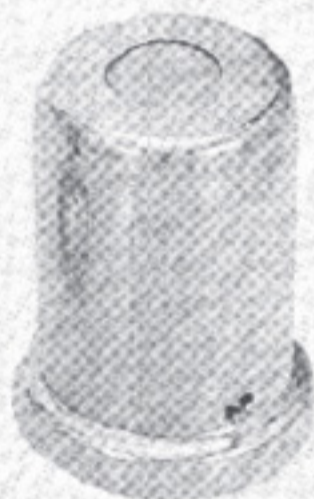

786-1151
Cotton holder

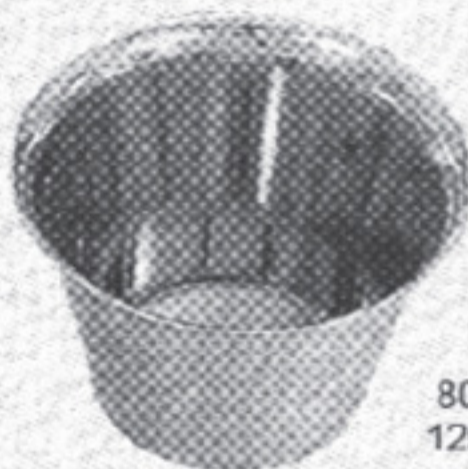

Round bowls

80x35 mm
125x60 mm

786-1152



786-1153
Spirit lamp



786-1154
Spirit lamp

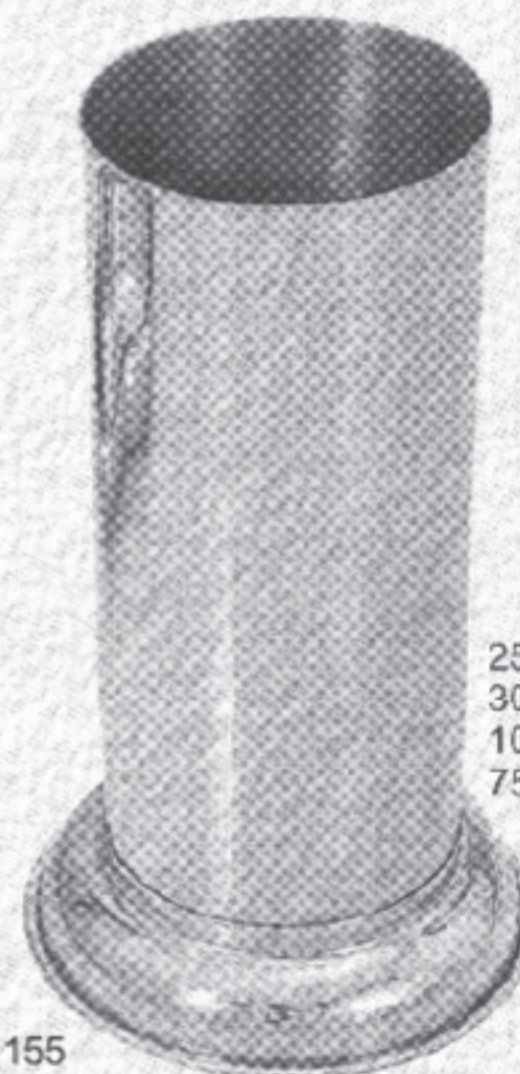

786-1155
Forcep Jar

25 x 80 mm
30 x 100 mm
100 x 200 mm
75 x 173 mm



Rubber Dam Clamps

Molar Clamps Winged



786-1156
Fig. 30



786-1157
Fig. 31



786-1158
Fig. 51

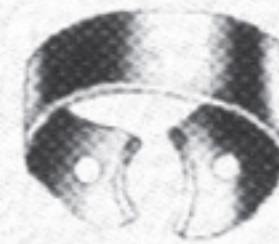

786-1159
Fig. 138



786-1160
Fig. 139

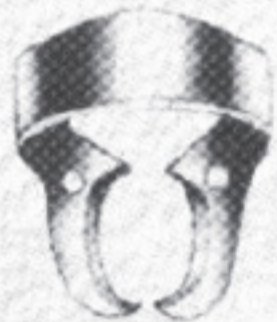

786-1161
Fig. 15



786-1162
Fig. 18



786-1163
Fig. 24



786-1164
Fig. 25

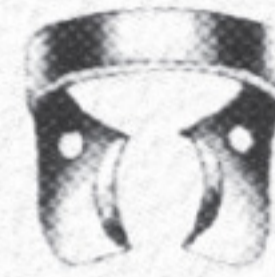

786-1165
Fig. 26

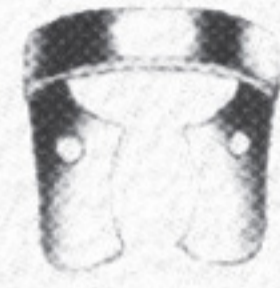

786-1166
Fig. 28

Bicuspid Clamps Winged



786-1167
Fig. 206



786-1168
Fig. 207



786-1169
Fig. 208



786-1170
Fig. 209



786-1171
Fig. 22



786-1172
Fig. 27



786-1173
Fig. 29

Molar Clamps Winged



786-1174
Fig. 26A



786-1175
Fig. 28A



786-1176
Fig. 30A



786-1177
Fig. 31A



786-1178
Fig. 51A



786-1179
Fig. 27



786-1180
Fig. 29



786-1181
Fig. 60

Bicuspid Clamps Winged



786-1182
Fig. 200



786-1183
Fig. 201



786-1184
Fig. 202



786-1185
Fig. 203



786-1186
Fig. 204



786-1187
Fig. 205

Molar Clamps Winged

Labial Clamps Winged



786-1188
Fig. 210



786-1189
Fig. 211

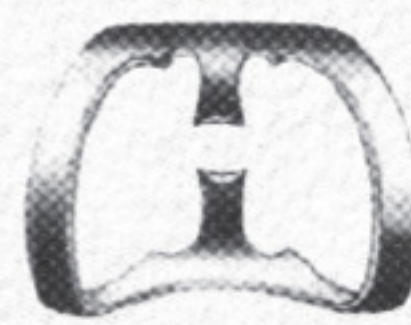

786-1190
Fig. 212